

MIDI SAMPLING WORKSTATION

DJ-70

Owner's Manual

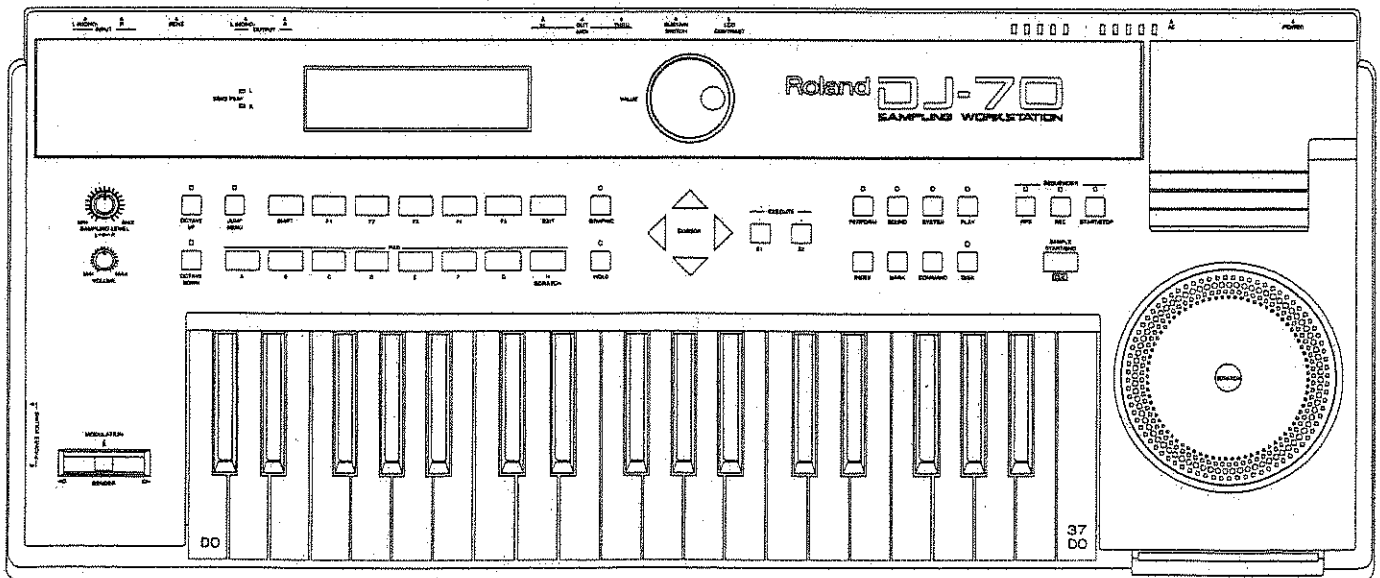

For West Germany

Bescheinigung des Herstellers/Importeurs

Hiermit wird bescheinigt, daß der/die/das
DJ-70 Sampling Workstation

(Gerät. Typ. Bezeichnung)

in Übereinstimmung mit den Bestimmungen der
Amtsbl. Vfg 1046/1984

(Amtsblattverfügung)

funk-entstört ist.

Der Deutschen Bundespost wurde das Inverkehrbringen dieses Gerätes angezeigt und die Berechtigung zur Überprüfung der Serie auf Einhaltung der Bestimmungen eingeräumt.

Roland Corporation Osaka/Japan

Name des Herstellers/Importeurs

- Dies bezieht sich nur auf die von Roland Elektronische Musikinstrumente Handelsgesellschaft mbH. vertriebenen Produkte.
- The above applies only for the products distributed by Roland Elektronische Musikinstrumente Handelsgesellschaft mbH.
- Ceci ne s'applique qu'aux produits distribués par Roland Elektronische Musikinstrumente Handelsgesellschaft mbH.

For the USA

RADIO AND TELEVISION INTERFERENCE

WARNING — This equipment has been verified to comply with the limits for a Class B computing device, pursuant to Subpart J, of Part 15, of FCC rules. Operation with non-certified or non-verified equipment is likely to result in interference to radio and TV reception.

The equipment described in this manual generates and uses radio frequency energy. If it is not installed and used properly, that is, in strict accordance with our instructions, it may cause interference with radio and television reception. This equipment has been tested and found to comply with the limits for a Class B computing device in accordance with the specifications in Subpart J, of Part 15, of FCC Rules. These rules are designed to provide reasonable protection against such a interference in a residential installation. However, there is no guarantee that the interference will not occur in a particular installation. If this equipment does cause interference to radio or television reception, which can be determined by turning the equipment on and off, the user is encouraged to try to correct the interference by the following measure:

- Disconnect other devices and their input/output cables one at a time. If the interference stops, it is caused by either the other device or its I/O cable. These devices usually require Roland designated shielded I/O cables. For Roland devices, you can obtain the proper shielded cable from your dealer. For non Roland devices, contact the manufacturer or dealer for assistance.

If your equipment does cause interference to radio or television reception, you can try to correct the interference by using one or more of the following measures.

- Turn the TV or radio antenna until the interference stops.
- Move the equipment to one side or the other of the TV or radio.
- Move the equipment farther away from the TV or radio.
- Plug the equipment into an outlet that is on a different circuit than the TV or radio. (That is, make certain the equipment and the radio or television set are on circuits controlled by different circuit breakers or fuses.)
- Consider installing a rooftop television antenna with coaxial cable lead-in between the antenna and TV. If necessary, you should consult your dealer or an experienced radio/television technician for additional suggestions. You may find helpful the following booklet prepared by the Federal Communications Commission:

"How to Identify and Resolve Radio — TV Interference Problems"

This booklet is available from the U.S. Government Printing Office, Washington, D.C., 20402, Stock No. 004-000-00345-4.

- Above statements apply ONLY to the products distributed by Roland Corporation US, 7200 Dominion Circle, Los Angeles, CA 90040.

For Canada

CLASS B

NOTICE

This digital apparatus does not exceed the Class B limits for radio noise emissions set out in the Radio Interference Regulations of the Canadian Department of Communications.

- The above applies only for the products distributed by Roland Canada Music Ltd., 5480 Parkwood Way, Richmond, B.C. V6V 2M4.

CLASSE B

AVIS

Cet appareil numérique ne dépasse pas les limites de la classe B au niveau des émissions de bruits radioélectriques fixés dans le Règlement des signaux parasites par le ministère canadien des Communications.

- Ceci ne s'applique qu'aux produits distribués par Roland Canada Music Ltd., 5480 Parkwood Way, Richmond, B.C. V6V 2M4.

Copyright © 1992 by ROLAND CORPORATION

All rights reserved. No part of this publication may be reproduced in any form without the written permission of ROLAND CORPORATION.

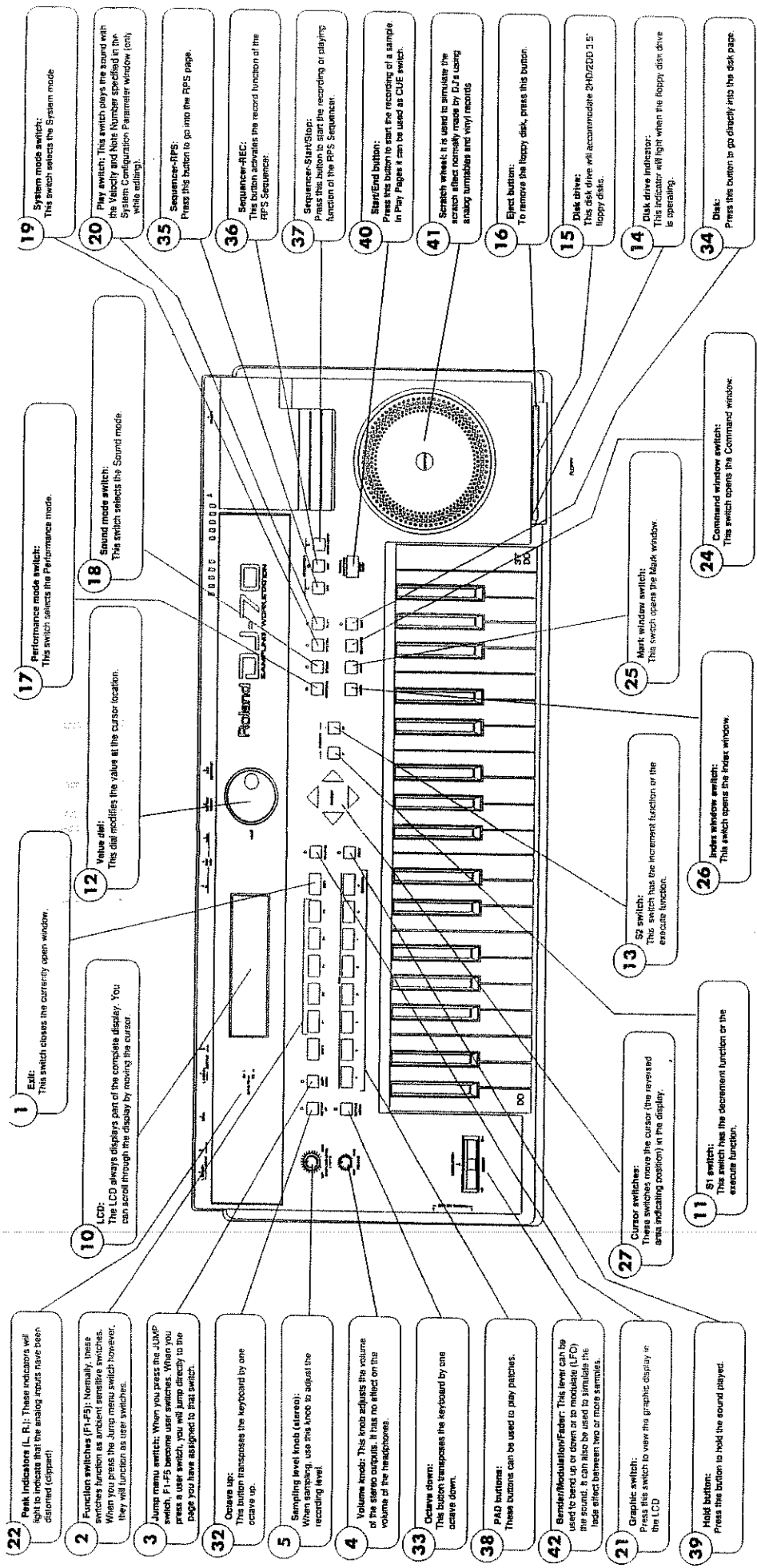

22 Peak indicators (L, R): These indicators will light to indicate that the analog inputs have been distorted (clipped).

2 Function switches (F1-F5): Normally, these switches function as ambient sensitive switches. When you press the Jump menu switch however, they will function as user switches.

3 Jump menu switch: When you press the JUMP switch, F1-F5 become user switches. When you press a user switch, you will jump directly to the page you have assigned to that switch.

32 Octave up: This button transposes the keyboard by one octave up.

5 Sampling level knob (Stereo): When sampling, use this knob to adjust the recording level.

4 Volume knob: This knob adjusts the volume of the user's response. It has no effect on the volume of the transponder.

33 Octave down: This button transposes the keyboard by one octave down.

38 PAD buttons: These buttons can be used to play patterns.

42 Bender/Modulation/Fader: This lever can be used to bend up or down or to modulate (LFO) the sound. It can also be used to simulate the Leslie effect between two or more samples.

21 Graphic switch: Press this switch to view the graphic display in the LCD.

39 Hold button: Press this button to hold the sound played.

10 LCD: The LCD always displays part of the complete display. You can scroll through the display by moving the cursor.

12 Value dial: This dial modifies the value at the cursor location.

17 Performance mode switch: This switch selects the Performance mode.

18 Sound mode switch: This switch selects the Sound mode.

35 Sequence-REC: Press this button to go into the RPS page.

36 Sequence-REC: This button advances the record function of the RPS Sequencer.

37 Sequence-Station: Press this button to start the recording or playing function of the RPS Sequencer.

40 Start/End button: Press this button to start the recording of a sample in Play Pages. It can be used as CUE switch.

41 Scratch wheel: It is used to simulate the scratch effect normally made by DJ's using analog turntables and vinyl records.

16 Eject button: To remove the floppy disk, press this button.

15 Disk drive: This disk drive will accommodate 2HD/2DD 3.5" floppy disks.

14 Disk drive indicator: This indicator will light when the floppy disk drive is operating.

34 Disk: Press this button to go directly into the disk page.

1 Exit: This switch opens the currently open window.

13 S1 switch: This switch has the increment function or the evaluate function.

25 Mark window switch: This switch opens the Mark window.

24 Command window switch: This switch opens the Command window.

26 Index window switch: This switch opens the Index window.

11 S1 switch: This switch has the decrement function or the escape function.

27 Cursor switches: These switches move the cursor (the reversed area indicating position) in the display.

26 Index window switch: This switch opens the Index window.

13 S2 switch: This switch has the increment function or the evaluate function.

26 Index window switch: This switch opens the Index window.

26 Index window switch: This switch opens the Index window.

26 Index window switch: This switch opens the Index window.

26 Index window switch: This switch opens the Index window.

17 Performance mode switch: This switch selects the Performance mode.

18 Sound mode switch: This switch selects the Sound mode.

35 Sequence-REC: Press this button to go into the RPS page.

36 Sequence-REC: This button advances the record function of the RPS Sequencer.

37 Sequence-Station: Press this button to start the recording or playing function of the RPS Sequencer.

40 Start/End button: Press this button to start the recording of a sample in Play Pages. It can be used as CUE switch.

41 Scratch wheel: It is used to simulate the scratch effect normally made by DJ's using analog turntables and vinyl records.

16 Eject button: To remove the floppy disk, press this button.

15 Disk drive: This disk drive will accommodate 2HD/2DD 3.5" floppy disks.

14 Disk drive indicator: This indicator will light when the floppy disk drive is operating.

34 Disk: Press this button to go directly into the disk page.

25 Mark window switch: This switch opens the Mark window.

24 Command window switch: This switch opens the Command window.

17 Performance mode switch: This switch selects the Performance mode.

18 Sound mode switch: This switch selects the Sound mode.

35 Sequence-REC: Press this button to go into the RPS page.

36 Sequence-REC: This button advances the record function of the RPS Sequencer.

37 Sequence-Station: Press this button to start the recording or playing function of the RPS Sequencer.

40 Start/End button: Press this button to start the recording of a sample in Play Pages. It can be used as CUE switch.

41 Scratch wheel: It is used to simulate the scratch effect normally made by DJ's using analog turntables and vinyl records.

16 Eject button: To remove the floppy disk, press this button.

15 Disk drive: This disk drive will accommodate 2HD/2DD 3.5" floppy disks.

14 Disk drive indicator: This indicator will light when the floppy disk drive is operating.

34 Disk: Press this button to go directly into the disk page.

25 Mark window switch: This switch opens the Mark window.

24 Command window switch: This switch opens the Command window.

17 Performance mode switch: This switch selects the Performance mode.

18 Sound mode switch: This switch selects the Sound mode.

35 Sequence-REC: Press this button to go into the RPS page.

36 Sequence-REC: This button advances the record function of the RPS Sequencer.

37 Sequence-Station: Press this button to start the recording or playing function of the RPS Sequencer.

40 Start/End button: Press this button to start the recording of a sample in Play Pages. It can be used as CUE switch.

41 Scratch wheel: It is used to simulate the scratch effect normally made by DJ's using analog turntables and vinyl records.

16 Eject button: To remove the floppy disk, press this button.

15 Disk drive: This disk drive will accommodate 2HD/2DD 3.5" floppy disks.

14 Disk drive indicator: This indicator will light when the floppy disk drive is operating.

34 Disk: Press this button to go directly into the disk page.

25 Mark window switch: This switch opens the Mark window.

24 Command window switch: This switch opens the Command window.

17 Performance mode switch: This switch selects the Performance mode.

18 Sound mode switch: This switch selects the Sound mode.

35 Sequence-REC: Press this button to go into the RPS page.

36 Sequence-REC: This button advances the record function of the RPS Sequencer.

37 Sequence-Station: Press this button to start the recording or playing function of the RPS Sequencer.

40 Start/End button: Press this button to start the recording of a sample in Play Pages. It can be used as CUE switch.

41 Scratch wheel: It is used to simulate the scratch effect normally made by DJ's using analog turntables and vinyl records.

16 Eject button: To remove the floppy disk, press this button.

15 Disk drive: This disk drive will accommodate 2HD/2DD 3.5" floppy disks.

14 Disk drive indicator: This indicator will light when the floppy disk drive is operating.

34 Disk: Press this button to go directly into the disk page.

25 Mark window switch: This switch opens the Mark window.

24 Command window switch: This switch opens the Command window.

17 Performance mode switch: This switch selects the Performance mode.

18 Sound mode switch: This switch selects the Sound mode.

35 Sequence-REC: Press this button to go into the RPS page.

36 Sequence-REC: This button advances the record function of the RPS Sequencer.

37 Sequence-Station: Press this button to start the recording or playing function of the RPS Sequencer.

40 Start/End button: Press this button to start the recording of a sample in Play Pages. It can be used as CUE switch.

41 Scratch wheel: It is used to simulate the scratch effect normally made by DJ's using analog turntables and vinyl records.

16 Eject button: To remove the floppy disk, press this button.

15 Disk drive: This disk drive will accommodate 2HD/2DD 3.5" floppy disks.

14 Disk drive indicator: This indicator will light when the floppy disk drive is operating.

34 Disk: Press this button to go directly into the disk page.

25 Mark window switch: This switch opens the Mark window.

24 Command window switch: This switch opens the Command window.

22 Peak indicators (L, R): These indicators will light to indicate that the analog inputs have been distorted (clipped).

2 Function switches (F1-F5): Normally, these switches function as ambient sensitive switches. When you press the Jump menu switch however, they will function as user switches.

3 Jump menu switch: When you press the JUMP switch, F1-F5 become user switches. When you press a user switch, you will jump directly to the page you have assigned to that switch.

32 Octave up: This button transposes the keyboard by one octave up.

5 Sampling level knob (Stereo): When sampling, use this knob to adjust the recording level.

4 Volume knob: This knob adjusts the volume of the user's response. It has no effect on the volume of the transponder.

33 Octave down: This button transposes the keyboard by one octave down.

38 PAD buttons: These buttons can be used to play patterns.

42 Bender/Modulation/Fader: This lever can be used to bend up or down or to modulate (LFO) the sound. It can also be used to simulate the Leslie effect between two or more samples.

21 Graphic switch: Press this switch to view the graphic display in the LCD.

39 Hold button: Press this button to hold the sound played.

11 S1 switch: This switch has the decrement function or the escape function.

27 Cursor switches: These switches move the cursor (the reversed area indicating position) in the display.

26 Index window switch: This switch opens the Index window.

13 S2 switch: This switch has the increment function or the evaluate function.

26 Index window switch: This switch opens the Index window.

26 Index window switch: This switch opens the Index window.

26 Index window switch: This switch opens the Index window.

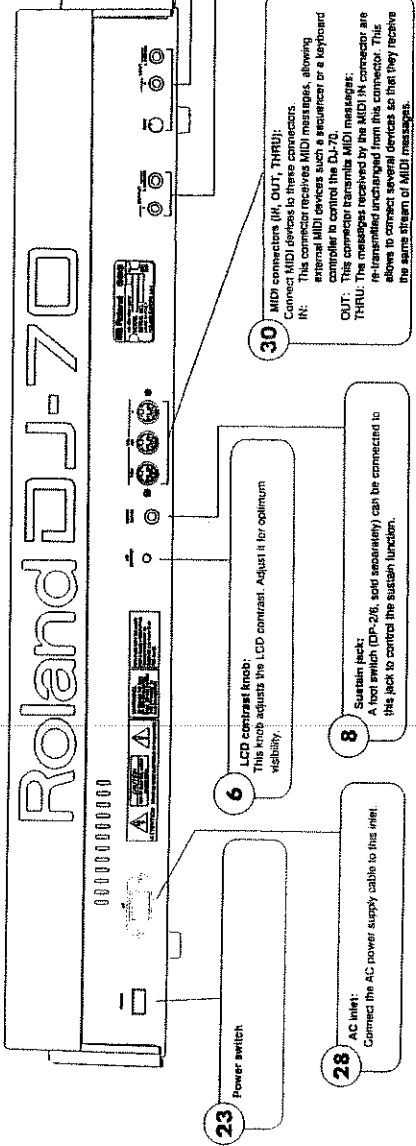

23 Power switch

28 AC inlet: Connect the AC power supply cable to this inlet.

6 LCD contrast knob: This knob adjusts the LCD contrast. Adjust it for optimum visibility.

8 Sustain knob: A foot switch (DIP-26; sold separately) can be connected to this jack to control the sustain function.

9 Input jacks: Input jacks (rear panel) accept the audio signals to be sampled. When connecting a monaural source, use the L (MONO) jack. Input sensitivity adjustment knob: Use this knob to adjust the input sensitivity to match line or mic input sources. For mic level signals (-50 dBm), rotate the knob completely to the left. For line level signals (-4 dBm), rotate the knob completely to the right.

29 STEREO out jack: This knob adjusts the volume of the phones out. It has no effect on the stereo.

30 MIDI connectors (IN, OUT, THRU): IN: This connector receives MIDI messages, allowing external devices such as a sequencer or a keyboard to communicate with the DJ-70. OUT: This connector transmits MIDI messages. THRU: The messages received by the MIDI IN connector are re-transmitted unchanged from this connector. This allows to connect several devices so that they receive the same stream of MIDI messages.

31 STEREO out jack: This knob adjusts the volume of the phones out. It has no effect on the stereo.

32 Octave up: This button transposes the keyboard by one octave up.

33 Octave down: This button transposes the keyboard by one octave down.

34 Disk: Press this button to go directly into the disk page.

35 Sequence-REC: Press this button to go into the RPS page.

36 Sequence-REC: This button advances the record function of the RPS Sequencer.

37 Sequence-Station: Press this button to start the recording or playing function of the RPS Sequencer.

38 PAD buttons: These buttons can be used to play patterns.

39 Hold button: Press this button to hold the sound played.

40 Start/End button: Press this button to start the recording of a sample in Play Pages. It can be used as CUE switch.

41 Scratch wheel: It is used to simulate the scratch effect normally made by DJ's using analog turntables and vinyl records.

42 Bender/Modulation/Fader: This lever can be used to bend up or down or to modulate (LFO) the sound. It can also be used to simulate the Leslie effect between two or more samples.

Index

Introduction	1	Making Connections	22
Easy Sampling Procedure	1	Power	22
Dedicated "DJ" Features	2	MIDI	22
Versatile Memory expansion	2	Audio	23
Copyright Warning	2	Outputs	23
Notes	3	Inputs	23
		Other Features	23
		Alpha Dial	23
		Scratch Dial	23
		RPS Sequencer	23
		Load While Playing	23
Easy Start	4		
How to Play the Demo Song	4		
How to record a sample	4		
Let's now get another sample	4		
Now let's try to modify the LOOP	5		
Play Page	5		
Now let's record a performance in the RPS sequencer	6		
Now let's save our work	7		
Now let's try to verify our saving procedure	7		
Cue Function	8		
Chapter 1:		Chapter 3:	
An Introductory Tour of the DJ-70	9	Structural and Operational Overview	25
Installation	9	A few notes before we begin this chapter...	25
Power	9	The Operating Screens	25
Audio	9	Modes	25
Powering up	10	Menus, Functions, and Pages	25
Loading Sound and Demo Song	10	The Command ("Com") Menu	26
Selecting Different Sounds to Play	11	Parameters	26
Exploring a Sound	11	Switches	26
Patches	12	Other things	26
Patch Common	12	Tools and Techniques	27
Split	12	Index	27
Control	12	Jumping Pages	27
Partials	12	The Select Window and the Scroll Arrows	28
Partial Common	13	Getting to a Function through Another Function	29
TVF	13	How the DJ-70 is organized	29
TVA	13	Samples	30
LFO	13	Partials	31
Samples	13	Patches	31
Looping	14	Performances	32
Phrase Sampling	14	Volumes	33
Saving your work	16	Working With Disks	33
Onwards	17	Loading	34
		Changing the Function Level (Target)	34
		Loading into RAM	34
		How much Room?	35
		A note about Lengths of Time	35
		Filling RAM Up	36
		Saving	36
		Using Floppies	36
		Disk Types and formatting	36
		One File per Disk	37
		But Several Disks per file	37
		Naming Files	38
		The ASCII Keyboard Window	38
		The Character Set	39
		Name Suffixes	39
		Executing the Name	39
Chapter 2:			
Installation, Controls, and Connections	19		
Position	19		
Controls and Front Panel	19		
The Rear Panel	21		

Chapter 4:

Patches

	41
Looking at a Patch — Basic Parameters	41
Selecting the Patch	42
MIDI Program Number	42
Patch Levels	43
Patch Priority	43
Offsets	44
Tuning	44
Splits	45
Multisampling	45
Drums and effects mapping	46
Examining the Split	46
Designing the Split	47
Using Parameters	47
Assignment types	48
Renaming Partials	48
MIDI Control	49
Controllers and controllers	49
The Parameters	49
Sample Shifting	49
Stalking the Wild Controller	50
Pitchbend	50
The controller Matrix	50
Combining controllers	51
The “Part” Parameter	51
Other Patch Functions	52
Disk	52
Copy	52
Delete	52
Initialize	53
Rename Partials	53
Partial Map and Edit Partial	53
The Patch Map	53

Chapter 5:

Partials

	55
Playing Partials from MIDI or Keyboard	55
Basic Parameters	56
Putting Samples into the Partial	56
Tuning Individual Samples	56
Transposition Limits	57
Changing the Scale	57
Other Parameters	58
SMT	58
Panning and Level	59
Velocity Switching	59
Velocity Fading	60
Other SMT controls	61
TVF	61
The Parameters	61
The Envelope	63
TVA	64
The Parameters	64
The Envelope	65
Using the Templates	65
LFO	67
Parameters	67
The LFO Assignments	68

Editing Partials through the Patch page	68
Restricted access to Partials	68
Automatic Partial Switching	69
Not Omni Mode	69
Global Editing	69
The Partial Map	70
Other Partial Functions (the Com menu)	70
Disk	70
Delete	70
Down and Down: Moving to the	
Sample Level	70
The Partial Map	71

Chapter 6:

Sampling 1 — Recording and Looping

	73
Recording a Sample	74
Setting the Parameters	74
Selecting the Slot and Naming	74
Mode: Mono or Stereo	75
Original Key	75
Freq	75
Time	75
Triggering	76
Automatic Triggering	76
Manual Triggering	77
Other Parameters	77
Doing the deed	77
Listening to the Results	78
Recording Samples from a	
Performance	78
Other Sampling Functions	79
Working with Stereo Samples	79
Converting Mono Samples to Stereo	80
Converting Stereo Samples to Mono	80
Editing Samples	80
Playing Samples while editing	80
Looping	81
Loop Mode	82
KeyOn Mode	82
Other Parameters	83
The Loop Point Parameters	84
Start	84
Sustain Loop	84
Release Loop	85
Restrictions and Relationships	
of the Loop Points	85
Timed Loops	85
The Graphic Window	86
The Waveform Display	86
Making it Sound Good	86
Point Mode	87
Editing in the Loop field	88
Advanced Loop Editing	88
Looping in Stereo	88
Looping tricks	89
Smoothing	89
Setting the Smoothing Length(s)	90
Executing the Smooth	90
Recovering from a Bad Smooth	91

Introduction

The DJ-70 Sampling Workstation is a brand new product designed for use in the Dance market. Drawing on Roland's extensive experience in sampler and synthesizer technology, it provides all the features that DJ, broadcasters and also non professional users want and need. The power and capacity of the DJ-70 removes many of the limitations of previous samplers, and make the DJ-70 a musical instrument and post-production tool that requires from the user no compromises or apologies.

This 37-note dynamic keyboard which boasts outstanding sampling qualities similar to the Roland S-770 is perfect for the ever increasing musical need of the "DJ".

By combining special design features, it can be used by both musicians and not-musicians alike. This Stereo 16-bit linear sampling keyboard offers features never before available for this market including TVA and TVF and 2 megabyte memory, expandable to 4 megabyte and complete compatibility with Roland S-770/750/550/330 and W30 samples.

With the expanded memory installed this 24-note polyphony with a mono sampling of 45 seconds at 44,1 Khz (and 90 seconds at 22,5 Khz) gives the "DJ" the ultimate tool for Dance sampling.

The DJ-70 is also equipped with an easy to use dedicate interface that makes the sampling and looping procedures much easier than other samplers available today. A Scratch Dial is included to simulate the "scratch" effect with digital equipment. Its outstanding versatility is further enhanced with an 8-track RPS sequencer and a large Back-lit graphic LCD Display.

The Built in 3,5 floppy disk drive unit (2HD/2DD) makes the DJ-70 the complete workstation not just for the "DJ" but for the Recording Studios, Television and Broadcasting stations and for the pure hobbyist.

Easy sampling procedure

Never before the sampling procedure has been as easy to use as the DJ-70. Just connect the audio source (CD, Tape Deck, Mixer, Microphone) to the Audio-Input and push the Start/End sample key. After the sample has been recorded, stopping the procedure automatically creates the Sample Patch and assigns it to a key on the Keyboard, to one of the 8 Pads, and to the Scratch Dial.

"Looping" now takes only minutes to perform and is done in Real Time. With the aid of the large back-lit LCD graphic display, just select the Start and Stop point. The Start/End button can also be used to "Cue" monitor new samples while others are being played which, until now, was only available on twin analog turntable.

Further sampling flexibility is created by the availability of a sampling speed control which permits the quickening or slowing down of a sample to enable synchronization with other sampled sounds.

Dedicated “DJ” features

A handy size “Scrath Dial” is included on the panel to enable with each sampled sound the classic “scratch” effect normally obtained only from analog turntable and vinyl records. With this feature unique to the DJ-70 it is possible to perform the scratch effect even with a compact disk.

Another invaluable feature which is essential for Real Time “DJ” performance is the “Load While Playing” function. The function allows the DJ-70 to be played continuously and without interruption while loading samples from the built-in 1,44 Mb 3,5 “ disk drive.

Versatile Memory Expansion

Equipped with a 2 Megabyte basic sampling memory, (22,5 sec. mono at 44,1 Khz or 45 sec. at 22,05 Khz) the DJ-70 can be expanded up to 4 Megabyte only using standard SIMM modules. With full memory installed, the DJ-70 can sample up to 45,3 sec. at 44,1 Khz (90 sec. at 22,05 Khz).

Unsurpassed sound quality is provided similar to the successful Roland S-750 and complete compatibility is guaranteed with all S-770/750/550/330/ and W30 sample libraries

Multi-Timbral mode can be selected when connecting the DJ-70 with a MIDI Sequencer giving a powerful multitimbral module with 24-voice poliphony and 31 parts. The DJ-70 Sampling Workstation mantains the same logical structure of the Roland S-750 samplers with many of the sys-772 software features like digital TVA and TVF, incorporating multi-mode filtering and resonance parameters. These features enable the creation and flexibility of a synthesizer. “Time Stretching” is also provided allowing you to “strech” or “compress” the sample data without affecting the pitch ; this feature is essential when working in synchronization with other sampled sounds. Sound data can easily be edited thus offering an extraordinary range of creative options. The final samples can then be channelled in a full stereo image.

Copyright warning

The DJ-70’s large memory makes it easy to record large segments of sound from live or pre-recorded sources. Keep in mind that using material belonging to other persons without their consent may be a violation of copyright law. When sampling material from CDs, cassettes, DATs, LPs, or broadcasts, please respect other people’s copyrights and do not break the law.

Notes

The DJ-70 interface is really easy to use. Now we will explain briefly some terms that we will use in this manual.

The DJ-70 is provided with a large LCD graphic display, a set of cursor buttons are used to move the cursor (an highlighted area) over any parameters displayed on the LCD screen. The S1 and S2 buttons have different functions in relation to the ambient in which they are used.

If the cursor is positioned over a parameter, the S1 and S2 buttons are used respectively to decrement or increment the value of the selected parameter.

If the cursor is positioned over a switch field or a menu option (a field that needs a confirmation) it works like an “EXECUTE”.

SELECT : The term select is used in this manual to indicate the operation of putting the cursor over a particular switch field or menu option and confirm pressing the S1 or S2 buttons.

All the Values of the parameter can be modified also putting the cursor over the selected parameter and rotating the Value Wheel.

Many of the LCD displays are not completely shown in the LCD area, so to see all the data use the cursor key to scroll the entire area.

The bottom zone of the LCD is often used to display a graphic representation of parameters. You can easily see that area scrolling the LCD using the cursor key or quickly pressing the “Graphic” button switch.

The 5 Function key are associated to different function related to the ambient in which you are.

The lower part of the LCD Display shows the name of the functions associated to each Function key. In some ambient you can access to other 5 function keys pressing the “SHIFT” button. The indication on the lower part of the LCD will change accordingly to the new Function keys.

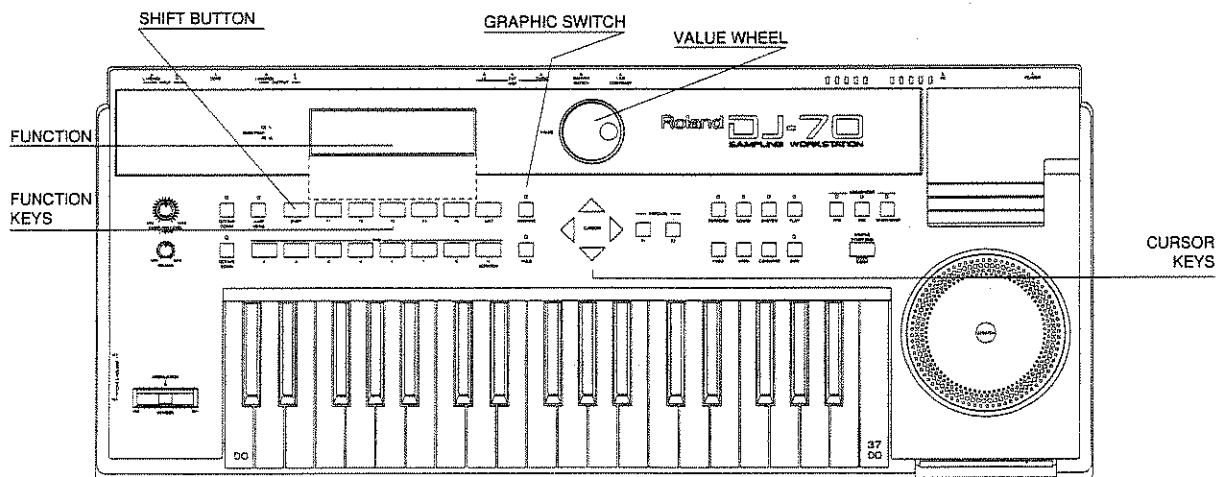

Easy Start

Now let's go to see briefly a collection of the Main features of the DJ-70.

- Connect your DJ-70 at the AC main using the provided AC cord.
- Connect the Left and Right outputs to an external amplifier.
- Connect the sound source (CD, TAPE, DAT, etc...) to the Left and Right inputs.

How to play the Demo Song:

- Power off the instrument.
- Insert the disk supplied with your DJ-70 labelled "Demo Disk".
- Power on the instrument.
- After the initialization procedure the DJ-70 automatically loads the Sounds and the Demo songs contained in the Disk.
- At the end of the loading procedure the DJ-70 comes back to the Play Page.
- Now press the Sequencer Start/Stop button to listen to the Demo song.

How to record a sample:

- Let sound your external source
- Adjust the Input sensitivity so that the Sens Leds will lit occasionally
- Press the F5 Function key (Sample)
- Now you are in the sampling page, here you can adjust any of the existing parameters, but they are always set for the common use. For now we will use the default values.
- Pressing the "Graphic" button we can see the LEVEL indicator.
- Adjust the Sampling Level so that the indicator remains in the central area.
Be careful to avoid an excessive level to prevent distortion.
- When you are ready press the F1 function key "Ready", the DJ-70 will show the Level indicator waiting for the sampling Start.
- Listening the incoming sound, at the point that you want to start recording, press the Start/End button.
- When you want to stop the recording, press again the Start/End button.
- If you reach the end of the sampling time set in the sampling page (4,5 sec Default), the recording procedure stops automatically and you will be back in the sampling page.
- Here you can listen to the sample just recorded by simply pressing the F4 (middle F) key.
- The sample is automatically looped, truncated at the right length and assigned, in the play page, to the first white key of the keyboard.

The DJ-70 has given to the sample the name "Sample1"

Let's now get another sample:

- Put the cursor over the name "Sample 1", press the S2 button to select the next sample slot (2: — empty —)
- Repeat now the same operations as above.

Now let's try to modify the LOOP:

- Select the sample to modify by putting the cursor over the "Sample" field and by using the S1 and S2 or the value wheel.
- Holding the "SHIFT" button press the F2 function key
- Now you are in the Loop Page.
- Press the "Graphic" button, the LCD will show the graphic representation of the selected sample.
- Press the F1 function key to select the modification of the "Start" point. Now by moving the value wheel or by pressing the S1 or S2 button you will change the length of the dark rectangle on the top of the window representing the sample length.

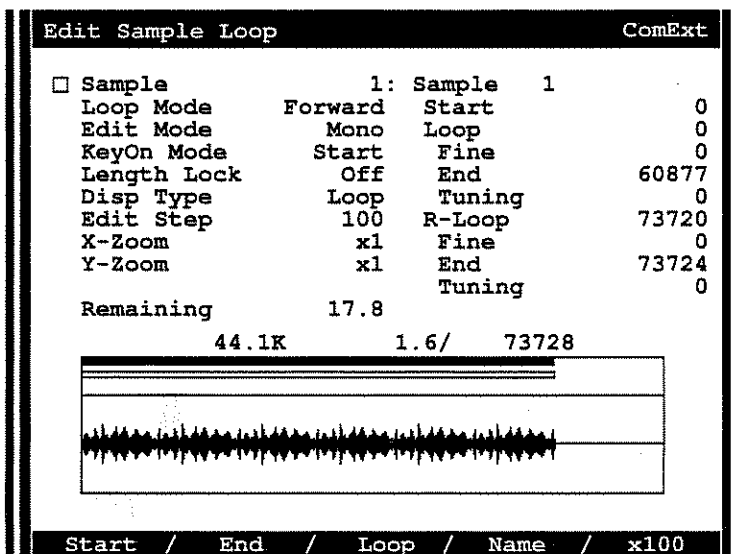

By playing one key on the keyboard you will listen the modifications made to the sample. The same procedure can be used to modify the other parameters associated with the other function keys.

Play page

Press the play button to come back to the play page, here you have the patch automatically created, assigned to the white key of the keyboard starting from the first left.

The same samples are assigned also to the pads starting from the pad "H" that is the pad reserved also for the scratch wheel.

So now you can play the samples, simply by pressing one of the keyboard key, one of the eight pad or by spinning the Scratch Wheel.

You can obviously change the assignment of any patch to the pad simply by putting the cursor over any of the fields of the split, by holding down the F3 function key (Pad Assign) and by pressing the pad to which you have to assign the patch. In the column indicating the associated pad, the selected pad will be shown.

By playing a key on the keyboard you will see an arrow at the left side of the associated split indicating which split is playing.

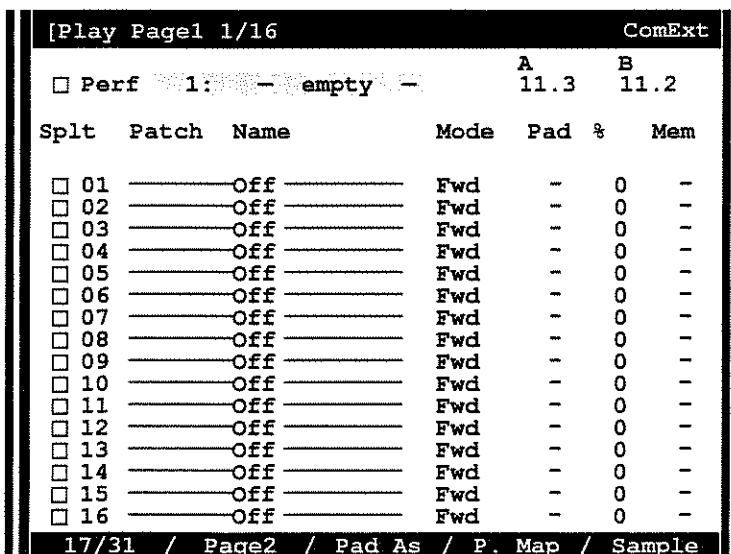

Put the cursor on the "Mode" field of the playing split, using the S1 and S2 buttons or the value wheel and set the parameter to "Alt" (Alternate).

In this condition the patch will be read alternatively forward and reverse. By playing again the same key you will listen to the result.

The field "%" works exactly as a speed control on an analog turntable. Put the cursor on the % field of the playing split; with the S1 and S2 buttons or the value wheel, modify the parameter and listen to the result.

[Play Page2 1/16						ComExt	
□ Perf 1: - empty -				A	B		
				11.3	11.2		
Splt	Patch	Name	Limits	Shift	Kb		
□ 01	-----	Off	C 2 C 7	0	On		
□ 02	-----	Off	C 2 C 7	0	On		
□ 03	-----	Off	C 2 C 7	0	On		
□ 04	-----	Off	C 2 C 7	0	On		
□ 05	-----	Off	C 2 C 7	0	On		
□ 06	-----	Off	C 2 C 7	0	On		
□ 07	-----	Off	C 2 C 7	0	On		
□ 08	-----	Off	C 2 C 7	0	On		
□ 09	-----	Off	C 2 C 7	0	On		
□ 10	-----	Off	C 2 C 7	0	On		
□ 11	-----	Off	C 2 C 7	0	On		
□ 12	-----	Off	C 2 C 7	0	On		
□ 13	-----	Off	C 2 C 7	0	On		
□ 14	-----	Off	C 2 C 7	0	On		
□ 15	-----	Off	C 2 C 7	0	On		
□ 16	-----	Off	C 2 C 7	0	On		

17/31 / Page3 / Lim L / Lim H / Sample

To switch between the three play pages you can simply press the F2 function key. At the top of the window the window number will be shown.

As seen above you can easily try to modify all the existing parameters in the play pages and listen to the result.

Note that many of these parameters give a result also if modified during the note play. Many others need to retrigger the note to listen the result.

[Play Page3 1/16						ComExt	
□ Perf 1: - empty -				A	B		
				11.3	11.2		
Splt	Patch	Name	Lev	Pan	Pb	Ch	
□ 01	-----	Off	127	0	Off	Bs	
□ 02	-----	Off	127	0	Off	Bs	
□ 03	-----	Off	127	0	Off	Bs	
□ 04	-----	Off	127	0	Off	Bs	
□ 05	-----	Off	127	0	Off	Bs	
□ 06	-----	Off	127	0	Off	Bs	
□ 07	-----	Off	127	0	Off	Bs	
□ 08	-----	Off	127	0	Off	Bs	
□ 09	-----	Off	127	0	Off	Bs	
□ 10	-----	Off	127	0	Off	Bs	
□ 11	-----	Off	127	0	Off	Bs	
□ 12	-----	Off	127	0	Off	Bs	
□ 13	-----	Off	127	0	Off	Bs	
□ 14	-----	Off	127	0	Off	Bs	
□ 15	-----	Off	127	0	Off	Bs	
□ 16	-----	Off	127	0	Off	Bs	

17/31 / Page1 / / P. Map / Sample

Now let's record a performance in the RPS sequencer

- Press the sequencer REC button.
- Start to play your performance, the Start/Stop Led will lit.
- At the end of your playing press the Start/Stop button, the Led will be Off. We have now recorded the first of the 8 tracks available in the sequencer. Now pressing the Start/Stop button you can hear the recorded track.

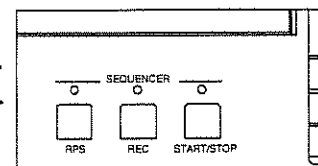

- Press the RPS button, you will see the Sequencer page, put the cursor over the field "Play Assign" of the track just recorded. By using the S1 and S2 buttons or the value wheel set the value "C#3 (49)". This setting allows you to start the track 1 simply by pressing the C#3 (49) key.
- Play the C#3 (49) key on the keyboard (the first C# on the left) and the sequence will start.

You can use this feature to create a complex pattern using short samples -and then assign the start of this pattern to one key of the keyboard.

- To record another track on the sequencer, put the cursor over any field of the track that you want to record, press then the F5 function key.
- The arrow on the right side of the LCD will move to the new recording track.
- Now execute the same operation described above to record the new track.

Realtime Phrase Sequencer						ComExt
Rps	On	Rec	KeyOn	On		
Perf	1	Stop	By C_5	(72)		
Type	Play	ass	Sh	Mode	Out	Rec
1 Trk	Strt/Stp		0	1Shot	Kbd	*
2 Trk	Strt/Stp		0	1Shot	Kbd	*
3 Trk	Strt/Stp		0	1Shot	Kbd	
4 Trk	Strt/Stp		0	1Shot	Kbd	
5 Trk	Strt/Stp		0	1Shot	Kbd	
6 Trk	Strt/Stp		0	1Shot	Kbd	
7 Trk	Strt/Stp		0	1Shot	Kbd	
8 Trk	Strt/Stp		0	1Shot	Kbd	
On/Off / / / Erase / Rec On						

Note that when starting to record the new track, you will hear the previously recorded tracks.

Now let's save our work

- Press the "Disk" button, the disk page will be shown.
 - Press the F4 function key to select the "Disk Save" function.
- At the top of the display the Target Item shows what kind of data will be saved ; Volume+Song is the default setting.
- Insert a blank diskette into the Floppy Disk Drive.
 - At the center of the display there is an area in which the name of the current "Volume" is shown. If you have not set the name, this name is automatically set by the DJ-70 ("Volume" + progressive number ie: "Volume1").

Disk Save		Ext
Target	Volume+Song	
Info:		
LOAD	1Files	
1:	:	10.0
		↑/↓
Internal Free		17.8 sec
Load A / Load B Load AB Save / Util		

- Put the cursor over the volume name and confirm by pressing the S1 or S2 button. If your volume needs more than one disk to be saved, the DJ-70 will ask you for another.
- At the end of the saving operation, the LCD will show "Complete". Now you can go back to the play page.

Now let's try to verify our saving procedure:

- Extract the Disk from the DJ-70 Floppy disk drive.
- Power off the instrument
- After 15 seconds power on again the instrument.

- Wait for the booting procedure
- When the play page is shown press the "Disk" button, the disk page will appear.
- If the "Load A/B" option is not selected, press the F3 function key, verify that "Volume+Song" is selected as target level.
- Insert the disk previously used to save your Volume
- In the listing area of the "Disk" Load page the name of the volume previously saved will appear.
- Put the cursor over the volume name and confirm by pressing S1 or S2.
- When the loading procedure is terminated the indication "Complete" will appear.
- Press the Play button and you will be now able in the "play page" to play the previously saved volume.

Cue Function

The DJ's mixers often have a function called "CUE" to pre listen in the Headphone a sample before to use it in the performance.

The DJ-70 has implemented a function similar to that. This function can be activated in the Play Pages using the Sample Start/End button. This button, only in the Play pages (1,2 and 3) works as Cue button.

Press and hold the CUE button, all the notes played after the CUE button is pressed will be heard only in the Headphone according also with the parameter "CUE Mode" in the System Parameter Page.

With the Cue function you can also control the scratch effect, just to find the right point of the sample to use for creating your best scratch effect.

The "CUE mode" parameter is used to decide what you want to hear in the Headphone when you press the CUE button.

Setting this parameter in "Single" you will hear only the sounds activated after the "CUE" button is pressed. In "All", you will always hear all the program, but after you have pressed the CUE button, the next samples will not be sent thru the L and R output until you release the CUE button.

Using an Headphone connected to the Phones Out you cannot hear the sounds coming from the input sockets.

Connecting a Mono Headphone to the "Main" Output you can hear the Main Output signal together with the input signal coming from the L and R inputs. Connect only Mono Headphones with impedance of not less than 30 ohm.

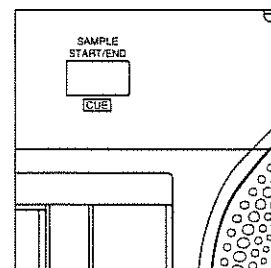

System PRM		Ext
Master Tune (cent)	1	
Cue Mode	All	
Monitor		On

Chapter 1: An Introductory Tour of the DJ-70

If you've just purchased your Roland DJ-70 Sampling Workstation no doubt you are very excited about it and would like to put it to good use immediately. The DJ-70 is a complex device, which is why this manual is so big, but it's not necessary to know everything about it right away, so in this chapter we will get you started with a few basic tasks. If you want to take a more formal, slower approach, feel free to skip ahead to Chapter 2. But if you want a quick tour of some of the unit's capabilities, read on.

When you are done with this chapter, you'll know a little bit about the DJ-70, but there is much, much more to learn. It is only intended to whet your appetite, so to get the most out of your instrument, it really is necessary to go through the entire manual.

Installation

When you remove the DJ-70 from its packing carton, place the unit on a solid flat surface, making sure you have access to the rear panel.

Power

Locate the AC power cord and insert the female end into the socket on the rear panel marked "AC IN". Check to see that the POWER switch on the rear panel is off (the button is out), and then plug the AC power cord's male end into an AC socket. Make sure the AC voltage matches the power requirements stated on the DJ-70's back panel.

Audio

Now connect the STEREO OUT jacks on the rear panel, using cables terminating in 1/4-inch phone plugs, to your mixer or amplifier and speakers. Alternatively, plug a pair of stereo headphones (with a stereo 1/4-inch phone plug) into the side-panel PHONES jack.

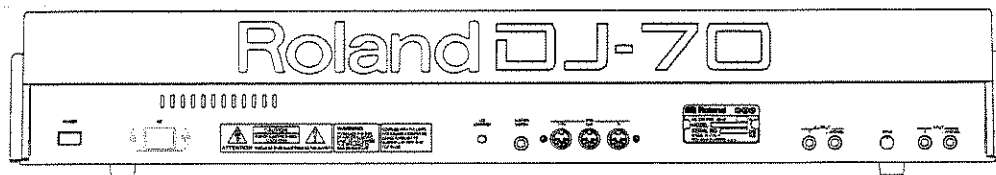

We will do a little sampling in this chapter, so connect an output from a CD player or cassette deck into the L(MONO) jack above the label INPUT on the back panel (this takes a mono 1/4-inch phone plugs also). (The DJ-70 will sample in stereo, but we'll save that for later.)

Powering up

Double check all your connections, and turn down the VOLUME and REC LEVEL controls on the front panel. Push the POWER switch on until it locks. Last, turn on the power to the mixer or amplifier you are monitoring with.

The LCD display on the front panel will light, and will show a variety of messages in sequence. First there will be System Loading, this operation will take few seconds. Then you'll see Wave Memory Check.

Finally, everything will quiet down, and the screen known as Play Page1 will appear on the LCD Display. Its name appears in the upper-left.

Loading Sounds and Demo Song

In the DJ-70, sounds are stored on Floppy-disks but before they can be played they must be loaded into the unit's Internal Memory (RAM). A disk with sounds and songs has been provided for you. It is labelled "Demo Disk ", put it into the drive.

We have to get to the Disk Load page in order to get the sounds off the floppy disk. Press the **Disk** button.

The Disk Load page opens. In the middle is a window showing the files on the disk. Only those files are shown that are at the current "Target level". At the top of the screen is the word "Target", and across from it is the word "Volume+Song". This means that the current Target level is Volume+Song, which is the top of the DJ-70's organizational hierarchy. A Volume can have many subsidiary files - called Performances, Patches, Partials, and Samples - and while a floppy disk can contain many files of various types, it can only contain one Volume. When you load in that Volume, all of its subsidiary files will load with it.

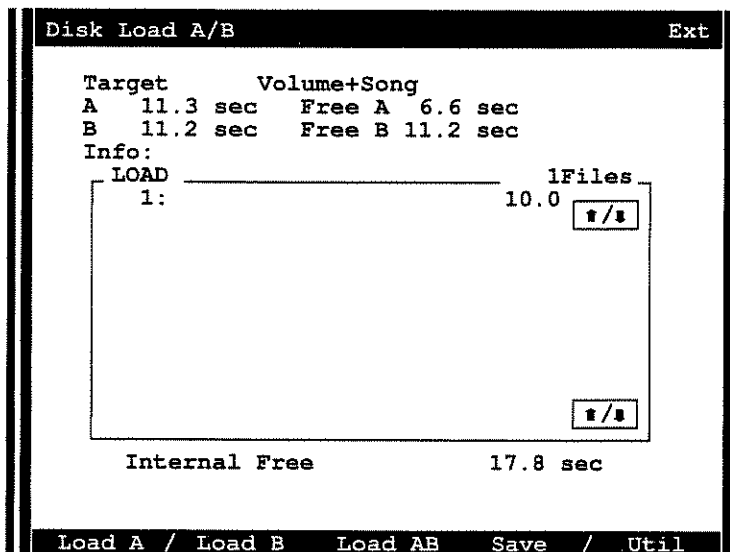

The Volume on this disk contains a variety of sampled sounds and one Demo Song. Move the cursor so that its name is highlighted, and press the S1 or S2 Execute buttons.

The disk spins, the words “Now Working” appear, along with five little arrows, rolling and tumbling. After a few seconds, the subsidiary files start to load in, and the LCD display shows each one as it loads. The Sample files, which go in first, take the longest, followed by Partials, Patches, and a Performance. When all the files are loaded, the “Now Working” changes briefly to “Complete”, and then the screen returns to the Disk Load page.

To play the sounds you’ve just loaded, we have to leave this page and go back to the Play Page. Press the Play button and we’ll go back to where we once belonged.

We are back on Play Page1. As you play notes on your keyboard, a little arrow will appear in the “Split” column, telling you which split is being playing.

If you don’t hear anything, check your connections again.

Selecting Different Sounds to Play

What you are hearing is a “Performance”. A Performance is a group of sounds arranged on different splits, with various other characteristics including stereo panning and level. A Volume can contain many Performances, but this one has only one. Its name appears at the top of the screen.

A Performance is made up of Splits, each one of which has a Patch, an assigned keyboard range, and some other parameters. If you play different keys in your keyboard, you will hear the different sounds in the different splits, and the arrow will appear in different places.

You can also change the Patch assigned in each split, so you can hear the different sounds without changing the played key: Put the cursor on the Patch name field of the first Split. That’s the name of the Patch you’re listening to pressing the C3 key. Press either the S1 or S2 button, and the Patch name assigned to the split 1 will change. Play the C3 keyboard key, and you’ll hear a different sound.

You can also view all of the Patches available in internal memory at a glance. At the far left of the screen, on the same line as each Patch name, are little rectangles, known as “Select icons”. Put the **cursor** on the icon associated with split 1, and press S1 or S2 button.

This opens a Select window, which shows all of the Patches currently in RAM. The current Patch is shown with an arrow. You can hear what any of them sound like by moving the cursor over its name so it highlights. If you press S1 or S2, you will be sent back to the Play page, with the Patch you selected now in the first split. This feature allows you to move quickly through a long list of files without scrolling through each one.

Exploring a Sound

Next on our tour we’ll examine how a sound in a Performance is constructed. We’ll look at what goes into a Patch first, and then move downwards through the organizational structure.

Patches

A Patch is a single “instrument”, with all of its internal and MIDI control parameters set. It is played on one MIDI channel, and can cover the entire 88-note range of the DJ-70. It’s essentially the same as a “Patch” that you would find in a single-timbre sampler or synthesizer.

Press the panel button “Sound”. This opens the Sound menu which is where you get access to the sound-editing Functions. Select “Edit Patch”.

Patch Common

The screen that now appears is the Edit Patch Common page. Select the line indicating the patch name, and press the S1 or S2 panel buttons until “Groove1” appears. This is now the “Current Patch”. Play the F_4 keyboard key, and you can hear this Patch by itself.

Split

Press the F2 function key (Split). This brings you to the Edit Patch Split page, which shows how various sounds (or “Partials”, the next level down) can be arranged on the keyboard, using the technique known as “Multisampling”, to build the Patch.

As you play on the keyboard, dots appear on the picture of the keyboard on the screen, showing the notes you are playing. Above the keyboard picture is a bar with a number of divisions. These show the split points. Select this parameter, and then press the S1 or S2 buttons. This will let you scroll through the various Partials that make up this Patch. As certain Partials’ names appear, an area of the bar will turn dark. This indicates the region of the keyboard that this particular Partial is “mapped” to - when you play a key in that region, that Partial is the one that sounds.

Control

Press the F3 button. This opens the Edit Patch Ctrl page, where you can determine how various types of MIDI data will affect the Patch. Select the line that says “Bend - Up”. This is a “Parameter”, which is currently set to 2. That means that when you move the Pitch Bend control up to its furthest position, the pitch of the sound will go up by 2 semitones (a whole step). Use the S1 and S2 buttons to increase (S2 button) or decrease (S1) this number, and note how it affects the action of the Pitch Bend control as you play.

Partials

As we’ve seen, Partials are the constituent parts of a Patch, and within a Patch, different Partials are played from different regions within the MIDI note range. Let’s go down a level and look at Partials.

First, let’s choose a different Patch (this one’s nice, but a little boring). Back at the top of the screen, scroll the Current Patch choosing another Patch. Now press the Command button. A

Com (short for Command) menu opens. Select “Edit Partial” and confirm by pressing the S1 or S2 button.

Partial Common

We are now at the Partial level. Let’s look first at the “Edit Partial Common” page. If the name at the upper left corner of the screen doesn’t say “*Edit Partial Common*”, press the F1 button.

This Page shows the current Partial that is sounding. As you move around the keyboard, the Partial changes, and the name of the Partial assigned to each key played is shown.

Each Partial is made up of one or more Samples (in this case, they all have only one, and it happens to be the same for all), which are displayed in four “slots” in the upper half of the screen. If different Samples were in each Partial then, as you move around the keyboard, they would change as well.

TVF

Press the F3 button (we’ll skip the SMT page for now). This brings us to the “Edit Partial TVF” page, where filter envelopes are created and edited. As you play different notes on the keyboard, the different filter envelopes for the different Partials are shown in the graphic in the lower part of the screen. The filter envelopes cause the “sweeping” effect in the sound.

TVA

Press the Function Key associated to the word “TVA” at the bottom of the page and confirm by pressing S1 or S2. This opens the “Edit Partial TVA” page, where you can work on the Partial’s “Time Variant Amplifier”, or volume envelope. The volume envelope is displayed at the bottom of the LCD Display (and the TVF envelope you just played with is in the background).

LFO

Press the Function Key associated with the word “LFO” at the bottom and confirm by pressing S1 or S2. This is the “Edit Partial LFO” page, where various types of vibrato can be applied to the Partial. Play with the Parameters “Pitch Mod Depth”, which control the amount of frequency-based vibrato; “TVA Mod Depth”, which controls the amount of amplitude-based vibrato (what used to be known as “tremolo”); and “TVF Mod Depth”, which imparts vibrato onto the filter (which can often result in a “wah-wah” effect). Also try adjusting the Rate and Delay parameters. Remember that each Partial has its own set of Parameters, so if you play different notes on the keyboard or via MIDI, the Partial will change and the Parameters on the screen will change.

Samples

Samples are the most elementary structure in the DJ-70. They are the actual sounds recorded by the unit, or transferred to it from another medium. Press Exit to get back to the Sound menu, and select and confirm “Edit Sample1”.

Looping

This is the Sample editing level, and we are looking at the Edit Sample Loop1 page (there's a Loop2 page, but it will have to wait until Chapter 6). Play the keyboard and you can hear this Sample, unadorned, with no envelopes or vibrato, and as you move around the keyboard, the Sample doesn't change.

Move the cursor to the parameter Loop on the right side of the screen. Select it, press the S2 button and hold it. The number in the parameter will increase. Look at the graphic waveform display at the bottom of the screen, and above the picture of the waveform (yes, that's what the Sample looks like), you can see a long rectangle shrink towards the right as the number increases.

Hold down a keyboard key, and listen to the sound. After an initial period, the sound starts to repeat, or loop. The number in the Loop parameter is the number of the specific byte within the Sample where the loop will start. As that number gets larger, the loop starts later, and the repeat time is shorter. The rectangle is a graphic representation of the loop. As the loop starts later, the rectangle gets smaller.

You will notice that at the point at which the loop repeats, it often "pops". Trying to get a good loop-repeat point without a pop or click is one of the fine arts of sampling. The DJ-70 is very good at that, and we will discuss it in detail later, as well as other operations available at this level.

Phrase Sampling

The DJ-70 has a lot of memory, which means it can deal with the most complex instrument sounds. But it also makes it ideal for working with longer sounds, like sound effects or entire musical or spoken phrases, manipulating them in various ways and playing them back on cue. Using the unit this way is often called "phrase sampling". Depending on how much memory you have installed, recorded sounds and phrases can be anywhere from a few seconds to several minutes in length.

So that we don't run out of RAM while we do this, we should clear the Internal Memory before we proceed. Go back to the Performance Play Page by pressing the Play button. Now press the Command button and confirm, select Delete from the Menu that opens up. Press the function key under the word "Pform", select "Volume" and confirm by pressing S1 or S2.

This operation removes all information that is currently in RAM, but it does not affect anything on the disk (all disk operations have to go through a Disk page). When the "CAU-

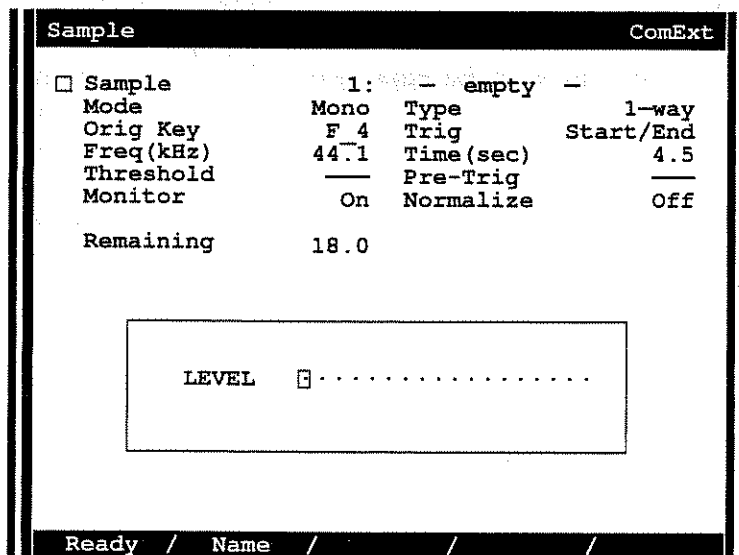

TION!!” window opens, select “Yes” and confirm with S1 or S2 button. A message window appears that says “Now working”, and in a second or two this window and the Delete window will close, and you will be back on the Play Page.

Now let’s get some sound. Press the F5 function key, the sampling page will open.

This page is where you record samples. To keep things simple, we’ll record a mono Sample. All the parameters are already set for common uses, but of course you can easily change any of these.

Earlier in this chapter you connected a CD or cassette player into the jacks on the rear panel, didn’t you? Now’s your chance to use it. Put a tape or disk into the player, and start it playing. Adjust the “SENS” control on the rear panel next to the input jacks so that the red LEDs immediately to the right of the control (they are hard to see when they aren’t on) flash only occasionally at the loudest moments.

Now look back up at the LCD Display , and watch the window at the bottom with the word “LEVEL” in it. A little box is dancing back and forth, showing the level of the incoming audio signal. If the box is jumping off to the right, the level is too high. If it is barely moving, or not getting past the mid-point of the window at any time, the level is too low. Adjust the “SAMPLING LEVEL” knobs on the left side of the front panel until the level is comfortable.

Before starting to record a sample you can set the name.

Press the Function key under the word “NAME”. A special “ASCII Keyboard” window opens. Towards the top of this window is an area containing a colon and a short horizontal line.

Move the cursor so that it is over the number “5” in the line of numbers. Press the S1 or S2 button. “5” appears in that area and the line cursor moves to the right. Move the cursor to where “[CR]” appears, and press S1 or S2. You’ve just named your new sample “5”. The ASCII window closes, and you are back to the Sampling Page, with the new name now appearing in the Name parameter.

Now press the Function key F1 assigned to “Ready”. A “Now working” message window appears briefly, and then the “Sampling execute” page appears. Get the CD or tape cued up just before the point that you want to sample, and start it playing. When it reaches the point where you want to start, press the Sample **Start/End** button.

At the bottom of the screen, a “thermometer” will fill up as the recording progresses. (If you would like to stop recording in the middle for any reason, press again the Sample Start/End button or press the “EXIT” button on the front panel. At the end of 4.5 seconds, the recording will stop, and a small “Now working” box shows itself briefly. To hear the sample already recorded , play an F4 on your keyboard. To hear it sped up or slowed down, play a different note. The sample is correctly looped, truncated to the right length and when you come back to the play page ,it is assigned to the first free white key of the keyboard.

If you want to correct the loop point by hand, press and hold the “SHIFT” button, the meaning of the five Function keys will change. Now by holding down the SHIFT button and by pressing the F2 function key you will go to the LOOP Page, play the keyboard, and listen to the loop you have set up. Adjust the Loop and End parameters with the S1 and S2 buttons, until you have a

loop that is sonically interesting, such as one bar of music, a complete spoken word, or a couple of beats of drum fill. What you are setting up is known as the “Sustain loop”.

Move the cursor up to “KeyOn Mode”, and press the S2 button twice, so that “R-Loop” appears. Move the cursor to the “R-Loop” parameter in the right-hand column, and press and hold S1 button until a second dark rectangle makes itself seen. This is the “Release Loop”, and you can hear what it sounds like by playing a MIDI key. The KeyOn Mode setting won’t let you hear the Sustain loop, just the Release loop.

Adjust the beginning and end of the Release loop with the R-Loop parameter and the End parameter just below it, until you get a Release loop that sounds interesting.

Now let’s put these together. Press the Exit button , and the Sound menu appears. Select Edit Partial. If the Edit Partial Common page doesn’t appear, press the function key assigned to Common at the bottom of the LCD Display.

Place the cursor on the word “Off” immediately under the word “Sample”. Press the S2 button once, and “5” appears in that field. What we have just done is to load the Sample “5” into this Partial.

Now go back to the bottom of the screen and press the F4 Function key “TVA”. This brings us to the volume envelope Page. If you play a note on the keyboard at this point, the sampled sound starts immediately, and then when the loop that you established on the Loop page is reached, it repeats as long as you hold the key down. We’re going to do better than that.

Underneath number “4”, to the right of the word “Time”, is number “1Ø”. Move the cursor to highlight that number, and press and hold the S2 button until it changes to 8Ø. Now play a keyboard key. The sound starts immediately, and as long as you hold down the key the Sustain loop repeats, but when you let go the key, the Release loop can be heard, and it repeats until it fades away.

Saving your work

The DJ-70’s internal memory is RAM - random-access memory - which loses everything in it when you turn off the power. If you want to save anything you’ve done, you must write it to an external medium, like a floppy disk.

Let’s save this new Sample “5” we’ve just created. Press the “DISK” Button on the front panel, press the Function Key assigned to the option SAVE.

We’re now on the Disk Save page. First, we have to determine what kind of file we want to save. That’s the job of the Target parameter. Move the cursor to it, and when it highlights, click the S1 or S2 buttons until it says “Sample”.

The file will be saved on floppy disk.
Put a blank disk in the drive, either Double Density (800K Macintosh/1 Meg IBM) or High

Density (1.4 Meg Macintosh/2 Meg IBM).

The name of the Sample currently in memory will appear in the window in the middle of the screen. Next to each is its length in seconds. Select “:5”, and confirm by pressing S1 or S2 , the Saving process begins.

First a window opens telling you how many files are being saved at what levels - you are saving one file at the Sample level - and how many disks, either High Density or Double Density, it will take to save them. If it's going to take more than one disk of the type you have, you should probably stop (select No), and choose a shorter Sample to save. To go on, select Yes.

Now a window will tell you that the disk needs to be formatted. Select “Yes”, the disk is automatically formatted, and the file is saved to it. Now you can turn off your DJ-70; next time you want to use this Sample, you can load it in from the floppy.

Onwards!

That's it for the quick tour. In the next chapter, we'll start working with the DJ-70 in a more formal, comprehensive manner. But don't think the fun's over. It's really just begun.

Chapter 2: Installation Controls, and Connections

This chapter will discuss in detail the various options you have for installing the DJ-70, and how to connect it to other components in your studio. It will also describe all of the front-panel and rear-panel controls and connectors.

Position

The DJ-70 can be put on a flat surface, like a shelf or table top. There is one set of ventilation holes in the front panel, near the power switch. Do not defeat them.

Do not place any heavy objects directly on top of the DJ-70. Do not put any devices near it (like a video monitor) that might cause hum or electrical or radio interference.

Controls and Front Panel

The VOLUME knob controls the signal level at the stereo outputs. It has no effect on the Phones output that has its own volume control. It should normally be set to “MAX”, because the DJ-70’s signal-to-noise ratio is higher at that point.



The DJ-70 has a muting function built into its power-up and power-down procedures, but it is still generally a good idea to turn down the VOLUME control when switching the unit on and off.



The SAMPLING LEVEL knobs control the level of the incoming audio signals which are being sampled.

The LCD screen shows the current Menu, Page or Window when operating the DJ-70. It only shows a part of the display, but when you use the Cursor buttons to access a Parameter, the screen scrolls.

The row of buttons F1 through F5, below the LCD screen, are used to move among Pages in

a Function - for example, when you are editing a Partial. You can use these switches to move from the volume envelope Page (“TVA”), to the filter envelope Page (“TVF”), to the vibrato Page (“LFO”), and so on. The name of the Page which corresponds to each button appears at the bottom of the LCD screen.

When the JUMP MENU button is pressed, F1 through F5 become switches that can move to Pages in other Functions - so you can instantly go from a Partial TVA page to a Patch Split page, for example. These “Jumps” are user-programmable, using the MARK button, described below (see Chapter 3 for a complete discussion of this).

The EXIT button is used to leave a page or window, and often to cancel an operation.

The LCD CONTRAST knob in the rear panel adjusts the contrast of the LCD screen. Normally this needs to be set only once after installation.

The PHONES jack takes a standard stereo 1/4-inch (tip/ring/sleeve) headphone plug. As mentioned above, its level is controlled with the Phones VOLUME side knob.

The SUSTAIN SWITCH jack is for a 1/4-inch plug from a normally-closed, single-pole foot switch such as the Roland DP-2 (available separately), which can be used to control sustain.

The INPUT jacks - L(MONO) and R - are for 1/4-inch plugs from unbalanced audio sources, that are to be sampled by the DJ-70. Stereo sources will use both jacks, while mono sources will use only the L(MONO) jack.

The SENS control is a pad between the INPUT jacks and the SAMPLING LEVEL control. Its furthest clockwise setting is appropriate for line level (+4 dBm) signals, and its furthest counter-clockwise setting is good for mic level (-50 dBm) signals.

On the Front panel there are two LEDs named L-SENS-R. They are there to help you set the SENS control.

The VALUE wheel is used to dial in Parameter settings, and also to scroll through items in a list. Its action is duplicated by the S1 and S2 buttons, but it is often a more efficient way of adjusting Parameters than the buttons.

The S1 button is used for choosing menu items and activating switches. The S2 button sometimes acts as an auxiliary to the S1 button. The two together are used to adjust Parameters and access items on a list.

The four cursor buttons or keys move the cursor from item to item on the display, up, left, down, or right, allowing you to select parameters to adjust, menu items to choose, and switches to activate (with the VALUE wheel and/or S buttons).

The floppy disk drive is for loading and saving files and system software on 3-1/2-inch floppy disks. Both double-density (800K Macintosh/1 Meg IBM) and high-density (1.4 Meg Macintosh/2 Meg IBM) disks can be used. You can insert a disk at any time (as long as there isn't one already in there). Remove the disk by pushing the rectangular button on the right side of the

drive. When the drive is in use, a yellow LED on its left side will light. When the operating system requires you to insert a disk, the yellow LED will flash. **WARNING! DO NOT** remove a disk when the LED is steadily lit.

PERFORM, SOUND, and **SYSTEM** are three operating Modes of the System software. Pressing the buttons of each of them opens up a Menu showing the various functions available within that Mode, which can then be selected using the cursor keys and S1 or S2 button. After you select a Mode, the LED in the button corresponding to that Mode will be lit.

INDEX calls up a special Index function on the LCD display, which lets you access operating Pages by selecting their topic. It's a very fast way for getting around the DJ-70, especially when you are first learning it.

MARK calls up a window from within a Page that lets you "mark" it as a "Jump" Page - one of the Pages that can then be accessed instantly using the JUMP button and one of the F buttons (see Chapter 3).

COMMAND opens a Command (or Com) Menu from within a Page, within which various Functions are available, including disk input and output, memory management, and other specialized tasks.

GRAPHIC instantly changes the LCD screen to show the bottom portion of the screen, if a graphic is present (picture of a keyboard, drawing of an envelope, etc.). It has a red LED of its own that lights when it has been pressed. Press it again and it returns the LCD screen to wherever it was before.

The Rear Panel

The **POWER** button turns on and off the AC power to the unit. "In" is on and "out" is off. Do not connect or disconnect the AC power cord with the switch on.

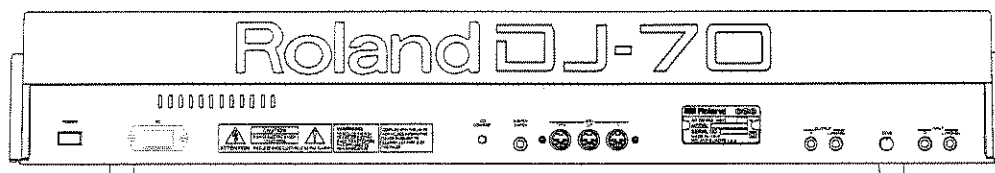

AC IN is where you plug the AC power cord. Be sure the AC line voltage in your studio matches the voltage requirements of the unit, as printed on the plate in the rear panel. Insert the cord here first, making sure the **POWER** switch is off, then plug the other end into the AC socket. Grounding is not necessary.

The **MIDI** connectors are standard. **IN** is for receiving performance data from a controller or sequencer, as well as System Exclusive data and Samples in the MIDI Sample Dump Standard

format. OUT is for sending notes coming from keyboard or sequencer, System Exclusive and MIDI Sample Dump Standard data. THRU echoes all MIDI data received at the IN port.

The **STEREO** outputs sends a mixed audio signal, with individual sounds programmable as to level and pan position within the stereo field. Regardless of what signal they are carrying, these outputs are controlled by the **VOLUME** knob.

Making Connections

Now that we know what everything does, let's start hooking things up.

Power

Before applying power to the DJ-70, make sure the line voltage is the same as the voltage rating of the unit, as stated on the metal plate located in the rear panel (100, 117, 220 or 240 volts). The DJ-70 will accept either 50 Hz or 60 Hz current.

As with any computer or sound-generating device, clean AC power is essential for proper operation of the DJ-70. Do not operate it on a line with any devices containing large motors, like refrigerators or air conditioners; with any devices that can generate electrical or radio-frequency interference, such as fluorescent lights, heating devices, or dimmers; or with any devices that consume a large amount of power and can cause fluctuations in the voltage level.

Do not connect or disconnect the power cord with the **POWER** switch on (pushed in).

MIDI

The DJ-70's **MIDI IN** jack should be connected to the **MIDI OUT** of whatever device is going to be controlling the unit: keyboard, drum controller, wind controller, guitar controller, hardware sequencer, or a **MIDI** interface from a computer running sequencing, sound editing, or other compositional software.

The **MIDI OUT** jack should be used to play external Expander or if you plan to send or store sounds externally using the **MIDI Sample Dump Standard**. Sounds can be transmitted this way to other samplers, and to computers equipped with sample-editing software, where they can be manipulated, and then returned to the DJ-70 (through the **MIDI IN** jack), or sent to other samplers, or stored.

The **MIDI THRU** jack provides an "echo" of the data going to the **MIDI IN** jack. It is provided as a convenience for "daisy-chaining" multiple **MIDI** devices together. Connect it to the **MIDI IN** jack of any other **MIDI** device that you would like to receive data from the same controller (keyboard, sequencer, etc.) that is controlling the DJ-70.

Audio

Outputs

The main outputs are the STEREO L and R outputs on the rear panel. They carry a stereo mix which can contain any or all of the sounds the DJ-70 produces. They are unbalanced, high-level low impedance (200 Ω), and are designed for connection to a mixing console, patch bay, or amplifier. Their level is controlled by the VOLUME knob on the front panel.

Inputs

Inputs are provided for signals that the DJ-70 will record for Samples. On the rear panel are two unbalanced 1/4-inch connectors, with an input-level range of approximately -50 to +4 dBm, and a continuous SENSitivity control. The inputs are further controlled by the SAMPLING LEVEL knobs on the front panel.

When the DJ-70 is recording in Mono mode, it only recognizes signals at the Left audio input, so if you are planning to record mono samples, make sure that's the channel you use.

Other Features

Alpha Dial

Alpha Dial (Value wheel) is provided to easily modify the values of the parameters. If you rotate it pressing the SHIFT button, the parameter associated will vary faster.

Scratch Dial

A Scratch Dial is provided to reproduce the scratch effect normally made by DJ's using analog turntable and vinyl records.

RPS Sequencer

An 8-track built-in sequencer with RPS function, allows you to record and play back your own sequences.

Load While Playing

The "Load While Playing" function allows you to load sounds while other sounds are playing without stopping your performance.

Chapter 3: Structural and Operational Overview

A few notes before we begin this chapter...

The Operating Screens

The DJ-70 has seven basic types or levels of operation: Modes, Menus, Functions, Pages, Parameters, Switches and Windows.

Modes

At the top of the operational hierarchy are the three Modes: Performance, Sound, and System. The current Mode determines in an overall sense what the DJ-70 is going to be doing. In Performance mode, the unit is a polyphonic, multitimbral, MIDI-controlled sound generator. In Sound mode, sounds can be recorded, edited, and combined. In System mode, basic operating parameters are set up.

The Mode can be selected using the dedicated buttons on the right side of the front panel. At just about any time, you can change the Mode by pressing the corresponding button: PERFORM, SOUND, or SYSTEM.

Although the Modes are essentially separate, there are various paths for moving between them, as we shall see.

Menus, Functions, and Pages

Each Mode has a Menu, which appears when you have selected the Mode. The menu shows the various **Functions**, or types of operations, available within the Mode. Choose a Function in the same way you chose the Mode: select the item you want on the menu with the cursor keys so that it goes into reverse video, and execute the selection with the S1 or S2 button.

This will bring up a Page. Each Function contains between one and five Pages. The full name of the current Page is shown in the upper-left corner of the page.

Change Pages by pressing the F-keys on the front panel: F1 selects the first page of the current Function, F2 the second, and so on.

There are also ways to get quickly to Pages in different Functions, which are known as Index and Jump. We'll discuss these a little later.

The Command (“Com”) Menu

A special type of menu is the Command or “Com” menu. It appears in many Pages towards the upper-right corner. Open it by pressing its own dedicated front-panel button, marked “COMMAND”.

The Com menu contains functions for accessing disks, managing internal memory (RAM), moving around the operational hierarchy in special ways, and various chores. Whenever you execute a function in a Com menu, after execution is done, the Com menu automatically closes.

Parameters

Parameters are the items on the Pages that do all the work. A Parameter can be a numeric value, or it can be the name of a file or other item chosen from a “list”. Parameters can be accessed by using the four cursor keys on the front panel. As usual, a Parameter will go into reverse video when it is selected.

Since Parameters can usually be adjusted up or down, the S1 and S2 buttons can be used respectively to increase or decrease their values, the VALUE wheel does too.

Switches

The Exit switch has its own dedicated front-panel button, marked (not surprisingly) “EXIT”.

Other Switches appear in other screens in various places, and may be labelled “Execute”, “Set”, “YES”, “NO”, “Name”, etc. Those switches can generally be accessed with the cursor keys, and activated with the S1 or S2 buttons.

Other things

Besides these categories, there are a few special items that you will encounter as you learn your way around the DJ-70, such as ASCII windows, graphic editing displays, and message and alert windows, which we will explain as we come to them.

Tools and Techniques

Index

An alternative way to move around the Pages in the DJ-70 is by using the on-screen Index. The Index is particularly helpful when you are first learning the unit, as it can find a Page or Parameter for you whose location you may be unsure about, without making you go searching through the Menus.

The Index can be called up any time by pressing the INDEX button on the front panel.

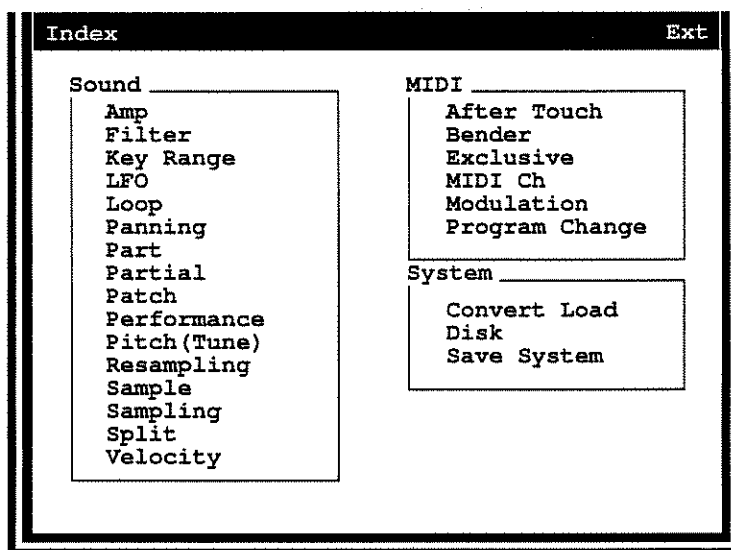

The Index displays a large number of “topics”, arranged in three groups. Topics under Sound deal with editing the sounds. Topics under MIDI deal with controlling the DJ-70 via MIDI. Topics under System deal with system operating parameters and disk access. Unlike the Modes, the organization of topics in the Index is not formal, and does not strictly follow the hierarchies and divisions of the DJ-70’s operating system.

With the cursor keys, choose a topic and confirm with the S1 or S2 buttons, the software will jump to the page where that topic is dealt with. Choose “Split”, for example, and the Edit Patch Split page will appear. Choose “Exclusive”, and the MIDI Configuration page, where System Exclusive is turned on and off, will appear.

Most of the Index topics, however, refer to more than one Page. When you choose one of these, a “subtopic” window opens. For example, there are various levels at which key ranges can be set for a sound, so if you choose “Key Range”, a window will open asking whether you want to work with key ranges at the Performance or Patch level. Choose one of those, and the appropriate Page will appear.

When you leave the Index (by pressing the Exit button), you will go back to the Menu or Page you were on previously.

Jumping Pages

The Jump feature allows you to move immediately between Pages located in different Functions and different Modes, bypassing the menus and the Index. There are ten pages available for Jumping, in two sets of five, and they are always available, regardless of what Page you are on.

Access the Jump pages by pressing the Jump Menu button located on the front panel. The Page names at the bottom of the LCD Display will all change to show the first set of five Jump

pages. Press the function key related to the page that you want to Jump to. The new Page will appear. Or, to see the second set of Jump pages, press the Jump Menu button again. To go back to the normal Page names, press a third time.

The DJ-70 comes pre-programmed with Jump pages in each of the ten “slots”. For instance, you can get right to the “Normalize” page by pressing the Jump Menu button and then pressing the appropriate Function Key.

You can change the Jump pages if you like. To program a Jump page, you must first bring up the Page you want to Jump to, using the conventional menus and page names. Then press the MARK button on the front panel. A window will appear showing the ten numbered Jump “slots” and the Pages currently installed in them, with both their full names (which due to space restrictions may be truncated) and their abbreviations as they appear on the screen. Move the cursor to the slot where you want to install the current Page and press the S1 or S2 buttons. The name in the slot will change to the name of the current Page. Close the window by pressing Exit button, and you will go back to the current Page.

To program the rest of the Jump pages, go to each Page that you want to jump to, press Mark, and then select the slot where you want that current Page to appear. Windows and Menus cannot be programmed as Jump destinations, and when a Window or Menu is open, the button “Mark” cannot be selected. If a name appears with *’s around it, it means the page being jumped to is in “Subsidiary” mode, and that it has arrived at through another Page. We’ll deal with exactly what this means shortly.

After you’ve programmed the Jump pages, there is one more thing you must do to make the programming permanent (so you don’t lose the Jump pages when you turn off the power). Go to the Index and select “Save System” - it’s down towards the bottom of the right column. The Save System window opens. Put a formatted Floppy Disk into the drive and select the SaveSys function. From now, if you want to have this set of Jump Menu, you have to boot the DJ-70 with this disk into the drive when powering on.

Now next time, and every subsequent time, you call up the Jump pages with the JUMP button, the Pages you have installed will appear at the bottom of the screen, and you can jump to any of them from wherever you are.

As you read this manual you will discover that the path you take to get to a Page is often very important. When you Mark a Jump page, the software memorizes not only the Page, but the path you took to get there. It’s certainly possible, and sometimes useful, to have the same Page with two different paths in two different Jump slots.

The Select Window and the Scroll Arrows

When a Parameter is the name of a file in a list, next to it is a little rectangle, which is known as the “Select Icon.” Selecting it opens the “Select Window”. This window shows all of the items in that file list. Rather than scroll the Parameter to see every item in the list, which can get very tedious with a long list (like all of the Samples in a Volume), you can open the Select Window, view them all, and just select the one you want. If you pass the cursor over the name of a file

without confirming on it, you can play that file from the keyboard to hear what it sounds like before committing to it.

The window shows 15 items at a time, at the file level indicated by the “Target” line: i.e., Sample, Partial, etc. An arrow points to the item currently selected in the Page you just came from.

If there are more than 15 items in the list, you can scroll the window using the Scroll Arrow boxes at the upper and lower right corners of the window. Place the cursor on the top box (with the single arrows) and press the S1 button or move the VALUE wheel counter-clockwise. The list moves down - that is, towards the beginning - by one item at a time. Press S2 or move the VALUE wheel clockwise, and the list moves up one item at a time. The lower box with the double arrows moves the list ten items at a time, so use this box to scroll quickly through a very long list. Scroll Arrow boxes show up in other places, too, as we shall see shortly.

Two other options are available in the Select Window. The “Sort” switch organizes all the files in RAM alphabetically, not only at the Target level but at every other level as well. Although it does not change the order in which the files appear on disk, it is a convenience for finding files when there are many in RAM. If you do it just before saving a large number of new files to a disk, they will be saved alphabetically on the disk as well. (There is a way to sort files once they’re on the disk, which we’ll show you in Chapter 9.) The “Blank” switch selects the next available empty slot as the Current file. This is useful when you want to work on a new file from scratch.

Getting to a Function through Another Function

Yet one more way of moving around the pages is available in a few circumstances. If you are working on any file that has subsidiary files - and this includes Performances, Patches, and Partials - you can move to a lower-level Function without exiting the Function you are in. For example, you can go from a Partial Edit page to a Sample Edit page (so that you can edit a Sample within a Partial) without going to the Sound menu. Then when you have done with the Sample Edit, you can press the Exit button and you will go right back to the Partial Edit page you were working on previously. This is accomplished through the Com menu, and will be explained in more detail in the chapters on sound editing.

When you are working on the lower-level editing, it is called being in “Subsidiary mode”.

How the DJ-70 is organized

Like most samplers, the DJ-70 records sounds and plays them back under Keyboard or MIDI control. The sounds are recorded in Internal Memory, or RAM, where they can be played back as they were recorded, or modified in a number of ways before or during playback. Some modifications to the sounds are destructive, meaning their basic identity is changed, while some are non-destructive, meaning they remain stored exactly as they were recorded.

Once recorded, sounds can be stored on floppy disk. The DJ-70’s RAM is volatile, that is, it erases itself whenever you turn the power off. Disks, however, are non-volatile: they can store data

indefinitely without power. Therefore, if you want to keep a sound you've recorded or altered in RAM, you must save it to a disk in order to be able to use it next time you turn on the unit. Sounds can only be played from RAM, so to use a sound stored on disk, you must first re-load it into RAM.

Besides permanence, disks have the advantage of much greater storage capacity than RAM. Disk procedures are discussed later in this chapter.

When working with a sound (in RAM or on disk), there are five organizational levels to deal with. Each of these organizational levels is a Function (as described earlier), and has its own set of Pages. We will examine these Functions starting from the bottom. The first three are accessed in the Sound mode, and the others in the Performance mode.

Samples

The basic element of sound is the Sample. A Sample is a single recording, mono or stereo, of an actual sound. It can be recorded by the DJ-70 itself, or recorded by some other device and transferred electronically into the DJ-70. A Sample can be any length, from very short (a few bytes, or so short you can't hear it), to very long (up to several minutes).

Samples are recorded on the Sampling page and edited on the Sample Edit pages, which make up the Edit Sample1 and Edit Sample2 Functions, which are selected from the Sound menu, or entered (in subsidiary mode) from one of the other Functions. On the Edit pages, Samples can be looped, smoothed, truncated, normalized, cut, pasted, time-stretched, digitally filtered,. With the exception of looping, all of these functions are destructive, and will alter the Sample permanently. However, you can "Recover" any operation you don't like, and go back to the original version. More in Chapters 6 and 7.

Samples are placed in RAM or on disk in numbered "slots", like the patches on a programmable synthesizer. There are a fixed number of slots available for Samples in RAM: RAM has 512 available slots for Samples. (The actual number of Samples you can get into RAM or onto a disk will often be lower, however, depending on the size of the Samples and the amount of space on the disk and in RAM - on a floppy disk, you won't get many at all.)

When a Sample is in a slot it has a name. (Empty slots are referred to by their numbers.)

The amount of space a Sample takes up in RAM or on a disk is a function of its length, its Sampling Rate Frequency, and whether it is stereo or mono. Samples use a lot of memory: even the shortest Samples you will be dealing with take several thousand bytes, and longer Samples can be in the Megabyte range.

When the memory capacity of RAM or a disk is referred to in this manual or on the display (it's also sometimes called "Wave Memory"), it's always in terms of the amount of memory available for storing Samples. Files from other levels of the DJ-70's organization, as we shall see, take up essentially no room at all.

Memory capacities and Sample lengths are usually referred to in seconds, but sometimes also in bytes. Some displays shows a "Remaining" parameter, which tells you how much space is available in RAM or on disk for Samples. (Although this Parameter is in "seconds", it may not

always reflect the actual amount of time a Sample lasts. This will be explained later in this chapter.)

Partials

Samples are combined into Partials. Each Partial contains from one to four Samples, which are layered - that is, they can all sound simultaneously. Each Sample within a Partial can have its own level, tuning (relative to the pitch it was recorded at), individual output assignment, and pan position in the stereo outputs. Samples within a Partial can also be velocity-switched, that is, different key velocities on the same note can sound different Samples, using the Sample Mix Table (“SMT”).

Partials are constructed and edited using the Pages in the Edit Partial and Partial Map Functions. Partials as a whole can be given a volume envelope (known as a Time Variant Amplifier, or “TVA”), and an analog-style filter with an envelope (Time Variant Filter, or “TVF”). In addition, a Low-Frequency Oscillator (“LFO”) can be applied to a Partial to provide pitch, volume, or filter vibrato.

Like Samples, Partials are stored on disk. The Samples that make up a Partial are known as its “subsidiary files”, and they are stored separately from the Partial itself. This means that the space on the disk that the Partial takes up by itself is actually quite small: it consists merely of a listing of the names of the subsidiary Samples, plus a couple of dozen parameters.

The same Sample can be shared among a number of different Partials - for example, a bass drum Sample might be used as part of a drum kit, or as a basis for an explosion effect. If you change it in one Partial, the change takes effect in every Partial in which the Sample is used. If you don't want this to happen, then the changed Sample should be copied and given a different name (which can be done in one operation) before it is altered.

When a Partial is loaded into RAM, the amount of memory it takes up is dependent on the size of the Samples that are associated with that Partial. If the Samples are already in RAM (because the same Samples have been loaded in previously with a different Partial), then loading in the new Partial will take up no additional RAM. You can also load a Partial without any of its Samples if you want to apply its Parameters to Samples already in RAM.

Partials, like Samples, occupy numbered slots when they are in RAM. The maximum number of Partials in RAM is 255. These numbers may be lower, however, depending on the size of the Samples associated with the Partials, and the amount of space in RAM.

You can create a new Partial without naming it first, and you can access it within RAM by its slot number. If you want to save it to disk, however, you must name it first - you cannot save a Partial that has just a reference number.

Patches

Partials are in turn combined into Patches. Patches are normally dealt with on the Edit Patch pages (although they can also be edited from the Patch Map page, which is accessed from the

Performance Play Function). Within a Patch, different Partials are assigned to different portions of the MIDI note range. A Partial's range within a Patch can be anywhere from 1 to 88 notes wide, and the notes need not be contiguous. (However, a particular note can have only one Partial assigned to it.) This feature, known as Split, and set up on the Edit Patch Split page, allows "Multisampling", a highly useful sampling technique. Multisampling avoids the "Mickey Mouse" effect that can occur when you play back a Sample at a pitch far removed from the pitch it was originally recorded at.

Each Patch has a MIDI Program Change number, which means that when the DJ-70 receives a Program Change command on the appropriate MIDI channel, this Patch becomes active.

Each Patch also contains a MIDI control matrix, which takes incoming MIDI data like Pitchbend, Channel Pressure, and Continuous Controllers and assigns them to various musical parameters, such as pitch, volume, filter (TVF) depth, and vibrato (LFO).

In addition, the Edit Patch pages have level, and tuning settings that can be used to augment or override the settings in the Partials.

The Partials and Samples in a Patch are "subsidiary files" of that Patch. Like a Partial, a Patch is merely a brief list of parameters, and by itself takes up essentially no room in RAM or on disk.

As with Samples, the same Partial can be shared among a number of different Patches. To go back to the bass drum example, you might want to use it as a bass drum in one Patch and tune it higher to use as a tom-tom in another Patch. If you alter the Partial in one Patch, then it will be altered in every other Patch in which it appears. Since saving a Partial by itself requires no extra memory, it is a good idea that every time you alter a Partial which may appear somewhere else, you copy it and save it with a new name.

The absolute maximum number of Patches that can be in RAM at any time is 128. These numbers may be lower, however, depending on the size of the Samples associated with the Patches, and the amount of space in RAM.

Partials can be created without names (just reference numbers), but they must be named before they can be saved to disk.

Performances

Performances are groups of Patches. A Performance is what you will have loaded into RAM most of the time when you are actually playing a piece of music with the DJ-70, whether it's live from the Keyboard, a MIDI controller, or from a sequencer. A Performance is what allows the DJ-70 to be a fully multitimbral sound generator, that is, one that can play different sounds on different MIDI channels.

Performances have their own Mode and Menu. Selecting Performance from the Mode menu or pressing the PERFORM button on the front panel opens the Perform Menu. Performances are edited using two different Functions in the Perform menu, Play and Edit Performance. (Note that

you can edit a Patch or other subsidiary file from within Performance mode - see Chapter 8).

Up to 31 Patches can be combined in a Performance. Each Patch is assigned a MIDI channel, so that the DJ-70 can respond to different MIDI channels with different sounds. Patches can also be layered by assigning two or more to the same MIDI channel. In addition, each Patch is given a MIDI keyboard range, which provides yet another opportunity for setting up multisampling splits, with the added feature that crossfades between Patches based on their keyboard position can be set up. Volume, Pitch Bender range, Loop mode, and pan positions can be assigned here as well to augment or override the settings in the Patches and Partial.

Like Patches and Partial, Performances themselves take up little room in RAM or on disk, but since they usually have quite a few subsidiary Samples associated with them, if you are loading a new Performance into RAM, it can take a little while. Also, changing a Patch in one Performance will change it in any other Performance in which it is used, so when making an alteration to a Patch that has multiple uses, it is a good idea to copy it into another slot.

The maximum number of Performances that can be in RAM at any time is 64. These numbers may be lower, however, depending on the size of the Samples associated with the Performances, and the amount of space in RAM.

Performances can be created without names (just reference numbers), and they can even be called up via MIDI Program Changes (see Chapter 8) that way, but they must be named before they can be saved to disk.

Volumes

Performances can be organized into Volumes. Volumes are very convenient: selecting a Volume to load into memory means a large number of Performances and their many subsidiary files can be accessed with a single operation. They also provide a good way to organize your data, and in fact the sounds provided on the floppy with your DJ-70 are organized into Volume.

Only one Volume can be in RAM at a time. Conversely, the entire contents of RAM can be considered as a single Volume. When a Volume is loaded in, another volume can be loaded in after it without clearing out the Internal memory, but now the contents of the two Volumes are considered as a single Volume. The name of that Volume will be the name of the most recently loaded Volume.

A Performance or other high-level file can draw its subsidiary files from different Volumes. Volumes can also share files - the same file can be in more than one Volume. Like Performances.

Working With Disks

As we mentioned earlier, sound files in RAM will disappear when you turn the DJ-70's power off. In addition, when you load in a new Volume (or any new file, if you tell the unit to clear its Internal Memory), all of the files in RAM will be erased. To store them permanently, they

must go onto a disk. Unlike some computer systems, the software does not automatically save RAM files for you, or give you a second or third chance to save them - you must take that initiative yourself.

There are four ways to get to the Disk Function, which is how you move files from RAM to disk and vice versa. One is through the Disk button in the front panel, this is the method you will use most of the time, the second is from the Command (Com) menu, available from all of the sound-editing Pages: open that menu and select Disk.. The third is from the System menu: choose System from the Mode menu or press the front-panel SYSTEM button, and then select the item Disk Tools. The fourth is through the Index: under System, select Disk. Finally, you can Jump there.

The Disk Function (no matter how you get to it) has five Pages: Load A, Load B Load A/B, Save and Util.

The DJ-70 memory can be divided into two areas (A / B). Each of these two areas can be loaded separately while the samples existing in the other area are playing.

Loading

Press the Disk button to go to the Disk page. Press the F3 Function key button to load both A and B areas. The center of the LCD Display will show a numbered directory of the current files on the disk, at one particular Function level - Samples, Partials, Patches, Performances, Volumes, or Volume + Song - as well as their total lengths, in seconds. (In some cases, these lengths might not seem quite right - don't worry, we'll get to that.)

Just above the length numbers will be a number showing how many of this type of file are on the disk: for example, "30 files".

Move the cursor buttons to select the file you want to load and confirm pressing S1 or S2 button. There is room for only 11 file names to appear on the screen at a time, so if there are more files that you want to look at, use the Scroll Arrows at the right side of the screen. As in the Select window, the upper arrows scroll by one, and the lower by 10.

Changing the Function Level (Target)

The directory shows one Function level at a time. Changing the level is accomplished by selecting the "Target" parameter at the top of the page, and using the S buttons, or VALUE wheel to choose the Function level you want to see - use the S2 button to go higher (up towards Volume) and the S1 one to go lower (down towards Sample). You can go beyond Sample as well to special "PRM" targets or "SONG" - we'll get to these shortly.

Loading into RAM

When you have selected the file you want to load into RAM, press S1 or S2 Buttons. If there are already sounds loaded into the DJ-70's memory, a window will appear asking you if you want to clear all of them out of RAM before you load in this new file. If you want to start from scratch, select the Yes switch. Remember if you do this, any sounds not saved to disk - newly recorded Samples, edited Partials or Patches - will be lost forever. If you want to hold on to what's

already in RAM and just add this new file to it, select No. If you don't want to do anything, select Cancel.

As the file loads, the words "Now Working" appear at the bottom of the LCD Display, and some white arrows will also appear, rolling and tumbling, while the disk is read. These arrows will become very familiar as you work with the DJ-70. They don't actually mean very much, but are provided to show that, in case you were worried by the apparent pause in activity, yes, the machine is working.

If you are loading in a Volume, Performance, Patch, or Partial, all of the Samples and other subsidiary files associated with the file will be loaded in as well. The Lcd will display the name of every file as it loads. (Here's where the dancing arrows mean something: how many there are indicates how many levels of files are being dealt with.) The files are loaded in ascending order: all the Samples first, then the Partials, Patches, and Performances. Since the Samples are the only ones with any real length, they take the longest.

However, if the Target is Partial PRM, Patch PRM, Performance PRM, or Song then the subsidiary Samples are not loaded. This is to allow you to use existing higher-level files as templates for working with different Samples. For example, if you wanted to use an existing drum map (a set of keyboard split assignments in a Patch) with a completely different set of Samples than it was designed for, you could load the Samples first, then the Patch without the Samples. This way you don't have to redesign the Patch from scratch.

How Much Room?

At the bottom of the LCD screen is a line of text labelled "Internal Free". This shows how much RAM is available for Samples, in seconds. As one or more Samples get loaded in, this number will go down. Since the directory shows the size in seconds of each file on the list, it makes it easy to determine beforehand whether there is room in RAM to accommodate it.

A Note about Lengths of Time

When any time length - whether it refers to a file, or to the space remaining in RAM or on disk - is shown on the LCD Display, the number may not correspond to the actual length in real time of the file or the memory. This is because time lengths are generally calculated as if the file or space were being processed at a sampling rate of 44.1 kHz - even though the DJ-70 is capable of operation at different sampling rates. The reason for this is so the display can be consistent: otherwise you might find yourself in a situation where there are 2.5 seconds free in RAM at one sample rate, and you have a Sample on disk 2.3 seconds long but it won't fit into RAM because it was recorded at a faster sample rate. By having all timings referenced to the same sample rate, this kind of confusion is avoided.

Therefore, if the Samples in a file were recorded at 44.1 kHz, the number shown for their total length will be exactly their actual length. If they were recorded at 22.05 kHz, the number shown will be less than the length. Here's an example: if a Sample on disk is 24.2 seconds long and was recorded at 22.05 kHz, its length according to the DJ-70 will be 12.1 seconds. If you

intend to load that Sample and the “Internal Free” display says “13”, you’ve got plenty of room to spare.

There are two exceptions to this: when you are recording a new Sample on the Sampling page, or when you are Resampling.

Filling RAM Up

When the RAM gets close to full, the loading operation may take longer, because the unit has to re-shuffle memory to accommodate new files. If you run out of RAM in the middle of a loading operation, you will get an error message: “Wave Memory Full”. No more Samples will be loaded, but the other files (if there are any) will be. You can always load files from a “PRM” target, because those files take up no memory.

Saving

Saving files in RAM to disk is done on the fourth Disk page, Disk Save. Select a Target, and all files of that type currently in RAM will appear in the directory window. If you have more than a screen’s full, use the Up/Down boxes to scroll.

Next to the file name is the size of the file in seconds, which takes into account all of the Samples associated with the file. (As with loading, if you save any high-level file, all of its subsidiary files are saved along with it.)

Remember that even if you are doing a non-destructive edit on a Partial or Patch, and that Partial or Patch is used in more than one higher-level file, the new version of the Partial or Patch will show up everywhere the old version did. So if you are making changes that might affect other files, save the changes with a new name (see the end of this chapter for information about naming files).

To leave the Save Page and get back to the Menu or Page you started from, press the EXIT button.

Using Floppies

Floppy disks are a convenient way to store files “off-line”. You can Save to them or Load from them. Their advantages are that they are cheap, easy to transport, universally compatible, and readily available. One 10-second 44.1-kHz Sample, for example, will require two 800k floppies to store.

Disk types and Formatting

The DJ-70 can use both standard double-sided/double-density (800k) and high-density (1.44M) 3-1/2” diskettes, just like those you would buy for many personal computers. As with all devices that use floppies, new disks must be formatted before using. However, you can Save a file to a floppy without pre-formatting it - the formatting operation is handled automatically.

On the other hand, if you are planning to use many floppies in an operation (to store either one large file or several small ones), you can save time by formatting the disks ahead of time. This is handled on the Disk Util page, the fifth Page of the Disk Function. Go to that page by pressing F5.

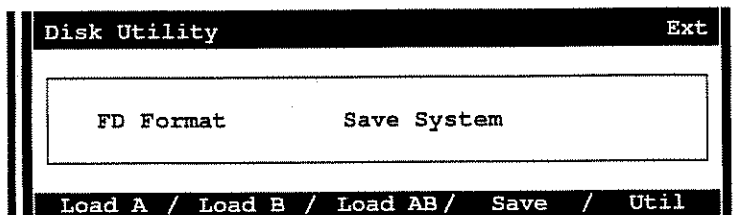

Insert the disk you want to format into the drive, making sure it is not write-protected: the write-protect tab should be snapped towards the center of the disk. Select FD Format.

The DJ-70 knows what kind of disk is in the drive, and formats it accordingly. Remember that formatting a disk erases everything on it. If the disk was previously formatted for the DJ-70 and contains either any Sample files or an operating system, the software will tell you so (“This is a Sound Data Disk!” or “This is a System Disk!”), and ask you again whether you want to format it.

If you have a disk in the drive you don’t want to format, you can push the eject button on the right side of the drive to get it out of there, and replace it with another disk. If you get confused or for some reason want to forget the whole thing, press the Exit button.

One File per Disk...

You can only save one file on a floppy disk. If you try to save another file, the first one will be erased (the software will warn you before this happens). However, the file that you save can be at any level, so you can, for example, store a Performance containing many Patches, Partials, and Samples on a floppy. You can then load in any of the subsidiary files to RAM. You just can’t save any of the subsidiary files individually to the floppy, without wiping out everything else.

A floppy disk can be either a System disk or a sound data disk, but not both. If you have previously used a disk to Save System (see Chapter 9), and you Save a sound file on it, the System will be erased. Similarly, if you Save System on a disk that has sound data on it, the sound files will be erased.

...But Several Disks per File

Very often, as we mentioned above, a file will need more than one floppy to hold it. An 800k disk will hold about 8.3 seconds of Samples at the 44.1 kHz Sampling Frequency, while a 1.44M disk will hold just about 15 seconds. If the file you’re saving is bigger than that, the DJ-70 automatically splits it up among as many disks as it needs. When the first disk is full, it asks you to insert another one. It automatically formats this disk (and warns you if there’s already something on it), and then continues to save the file. It will keep asking for more disks until its hunger is satiated.

As you use a disk, put a label on it and number it! Don’t put the disks away just yet - when the procedure is done, the DJ-70 will ask for all of them again, for just a moment, so that it can do its own numbering.

Keep track of all of these disks; if you lose or damage just one, you will not be able to load the file back in. Remember that none of the disks you've just saved can have anything else written to it, or the contents will be lost, which will likely make the other disks containing the rest of the file useless.

If you need to cancel a multiple-disk operation in the middle, you can do so. On a Save, if you run out of blank disks halfway through the operation, when the LCD Display tells you to insert another disk and asks if you want to continue, select No and the whole thing will be cancelled. If you cancel a multiple-disk save, some of the files may get saved to disk anyway.

Never remove a floppy disk while the drive is running (the yellow LED on the drive is lit steadily). This could damage both the disk and the drive. However, don't be afraid to insert a disk when the yellow LED is flashing, which will happen fairly often.

The DJ-70 can load sounds from disk libraries created for the Roland S-550, S-330, and W-30. This is a special operation called "Convert Load".

Naming Files

Every file at every level in the DJ-70 has a name. Names are given to files only when they are in RAM, and those names stick with the files when they go to and from disk.

Every name can be up to 12 characters. The last two or three characters are sometimes used for special suffixes: "-L" and "-R" for the two halves of a stereo sample; "-N" for a Sample that's just been copied; and "AA", "AB", etc. for a higher-level file that's been copied.

Filenames must not be unique. For example, you can have two Samples named "LoTom1" because they are set in different slots numbers.

The ASCII Keyboard Window

Names are given to files from within their respective Edit Pages. Select the Name function key , and a window labelled ASCII Keyboard opens. Here is where you construct the name.

The top line of the ASCII window shows the name. If you are renaming a file that already has a name, that name will be displayed. If you are constructing a new file, the line will contain the last name that happened to be displayed in this window - this makes it easy to name, for example, a new Partial with the same name you just used for a new Patch (and since the files are at different Function levels, there is no conflict). If this is the first time you have entered the window since powering up, it will be blank.

An "underline" cursor appears on the name line. The position of this cursor shows where you are about to insert a character. Move the cursor back and forth by selecting the cursor movement near the lower-right corner of the window.

When the underline cursor is in position, move the cursor , using the front-panel cursor

keys into the “qwerty” typewriter-keyboard area below it. Put the cursor on the letter, number, or punctuation mark (or [Space]) you want to insert at the underlined position, and press S1 or S2 buttons. The character will be inserted and the cursor will move one space to the right.

The first time you use this window in a session, it will be in “Overwrite” mode - “[O.W]” will appear to the right of the name. This means that any character you insert on the name line will replace the character previously in that space. If you select [O.W], it changes to “[INS]”, for “Insert” mode. Now any character you insert will move all characters after it one space to the right. Characters that get pushed off the right edge are lost.

You can also enter or change a character directly on the name line by moving the cursor (not the underline cursor) to the position where you want the character to go. Use the S1 and S2 buttons or VALUE wheel to scroll through the available character set until you reach the character you want.

To remove a character, select “[DEL]” (Delete) or “[BS]” (Backspace) and confirm (S1 or S2). Delete eliminates the character above the cursor, while Backspace takes out the character one position to the left of the cursor. All characters to the right of the cursor are moved one position to the left.

The Character Set

The character set available to you includes a full set of upper-case letters and alternative punctuation. You can get to these by first pressing and holding the SHIFT button, before selecting a character with the S1 or S2 buttons. When you press the SHIFT button, the “qwerty” area changes to show the upper-case characters. Keep holding the SHIFT button while you select the character you want and press the S1 or S2 buttons.

Name Suffixes

The Suffixes at the end of the filenames are important, and should be left alone for now. For two Samples to be recognized as a single Stereo Sample, for example, they must have identical names except for the “-L” and “-R” suffixes. Changing or eliminating either of the suffixes will make it impossible for the software to work properly with the Samples. The “-N” suffix appears after a Sample is copied, to differentiate it from the original version. When other files are copied, they get a two-letter suffix: “AA”, “AB”, etc. Any of these copies can be saved to disk, with or without re-naming.

Executing the Name

When you are done naming the file, select [CR] (Carriage Return). If all is well, the ASCII window will close, and the new name will be applied to the file currently on the LCD Display. (If it had an “-N” suffix, that suffix will be dropped). You can now save it to disk under that name if you like.

If you do not want to keep the name you’ve created, press the EXIT button and the ASCII window will close without changing anything.

Chapter 4: Patches

As you've already learned, the organization of the DJ-70 is complex, and the more you get into it, the more complex (and more interesting) it gets. To guide you through this in as smooth a fashion as possible, we're going to start working with the unit's system software in the middle of the organizational table, and work our way downwards, then we'll go back up to the top. As you go through the manual, you will see how this approach makes sense.

At the top of the Sound menu is Edit Patch. Patches incorporate Partials, which in turn incorporate Samples. Patches are complete, performable instruments. They have envelopes, they cover the entire keyboard range (if you want them to), and they can have several MIDI controllers assigned to various parameters for real-time performance control.

When editing a Patch, it can be played from the Keyboard or via MIDI. In most cases the DJ-70 will be in Omni mode, so the MIDI keyboard can be set to transmit on any channel.

There are several ways to get to one of the Edit Patch Function's three Pages:

- open the Sound menu and select Edit Patch,
- select Patch from the Index, and Patch Common from the subtopic window,
- select any of the other possible topics in the Index that apply to the Patch pages, which are numerous, and then selecting the appropriate subtopic (for example, Panning In...Patch Common) from the menu that appears,
- use a Jump page that has been previously programmed
- go through any of the Performance pages. You move from a Performance page by opening the Com menu, and then selecting Edit Patch. When you call up a Patch page from a Performance page, the Patch page behaves a little differently, which we will explain at the end of this chapter and also in Chapter 8.

In all cases, when you Exit a Patch page, you will go back to the page or window you came from: either the Sound menu or the Performance page.

Looking at a Patch - Basic Parameters

Let's start by loading in a new set of Patches to play with. Select Edit Patch from the Sound menu. Make sure you're looking at the Edit Patch Common page. If you're not, press F1 on the front panel.

Now press the Disk button. Make sure the Disk Load A/B page is showing. Select the

Volume to load. If the screen asks if you want to delete all Internal Sound Data, select Yes. When the Volume is done loading, press the Exit button, and you will be back on the Edit Patch Common page.

Selecting the Patch

At the top of the Page, you can select the Patch you want to work on - the "Current Patch" - from any Patch in RAM. Highlight the name of the Patch on the first line of the screen with the cursor keys, and then move through the list of available Patches with the S1 and S2 front-panel buttons, or the VALUE wheel. There are many Patches available in the Volume you've just loaded.

Besides a name, every Patch also has a number, denoting its "slot", or position on the list of Patches in RAM.

There's another way to select a Patch. The word "Patch" has a Select Icon next to it, so you can put the cursor there and confirm on it opening a Select window. Here you can view all the Patches currently in RAM and choose one as the current Patch - just putting the cursor on the Patch's name and confirming pressing S1 or S2. You can also sort them alphabetically, or set up a blank Patch from which you can construct a new Patch from scratch.

Back on the Common page, below the name of the Patch is the "Select/MIDI in" setting. This determines which MIDI channel the DJ-70 will respond to while you are editing the Patch. For now, it should be set to "Omni On" - if it isn't, select it and hold down the S2 button until it is. More about this Parameter at the end of this chapter.

Next to the Patch name is a "Name" box. Selecting this, opens the ASCII Keyboard window in which you can rename the current patch, as discussed in the previous chapter. Remember a new name is not permanent until the Patch is saved to disk.

MIDI Program Number

The first parameter below the name is Program Number. This determines which incoming MIDI Program Change command number, 1 through 128, will call up this Patch when you use it in a Performance. The Program Change numbers for the Patches in the Performance are normally the same as the Patch's own slot number, and in fact the slot number is the default Program Change number when the DJ-70 creates automatically a new Patch. However, you can change this Parameter to anything you like, and the new number becomes part of the Patch when you save it.

Although obviously it is to be avoided, it is possible to assign the same Program Number

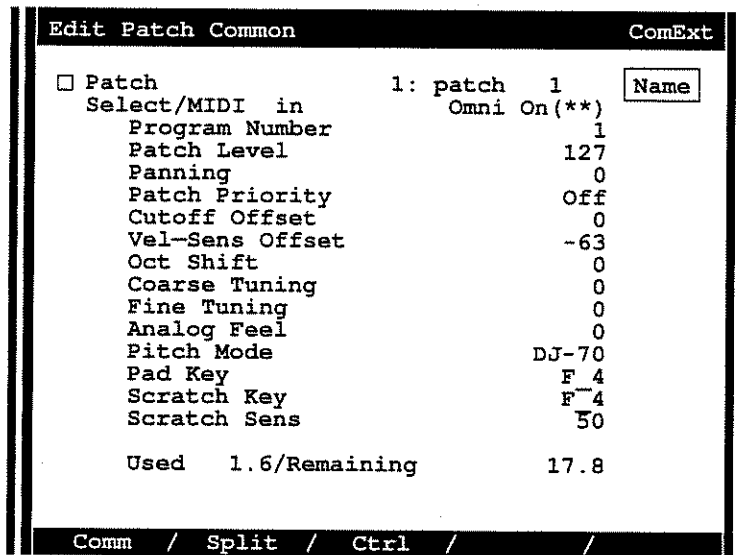

to more than one Patch. What happens when this is the case we'll also deal with in Chapter 8. Be aware as well that Program Changes are used to call up entirely new Performances, as well as Patches, and if there is a conflict - if both a Performance and a Patch are assigned to the same Program Change on the same MIDI channel - the Performance will take precedence, and the Patch will not change. The DJ-70 has a special "Basic Channel" to handle Performance changing, and it is usually best to avoid changing Patches on that channel. More on this in (you guessed it) Chapter 8.

Patch Levels

Patch Level sets an overall output level, from 0 to 127, for the Patch at all outputs, stereo and individual.

Panning moves the sound of the Patch in the stereo field. The range is L32 (hard left), to 0 (center), to R32 (hard right). This parameter influences, but does not replace, similar parameters in the Partials, which we'll discuss in the next chapter. If a Partial has Pan characteristics of its own, then setting this Parameter to L32, for example, will not cause all of the sound to emanate from the left channel only; but it will "bias" the image so that the sound will never emerge any further right in the stereo image than dead center.

Here's an example. Select a Patch that contains samples assigned to "RND" panpot. Set its Panning parameter to R32. Play notes on the keyboard and listen carefully to how they place themselves in the stereo field. Each note occurs at a different place between extreme right and center (the placement is not pitch-related, it is random - we'll see how this is done in the next chapter). Change the Panning parameter to 0. Notice how the sound now spreads out so that different notes appear across the entire stereo field. Now change Panning to L32, and hear that the sounds now occur between center and extreme left.

While you're playing with this Parameter, there are two things worth paying attention to:

- First, changing the Parameter does not affect any notes currently sounding - it affects the next note to sound after the change. This is true of most DJ-70 Parameters, although some will change the sound in "real time".
- Second, the cursor and LCD screen action of the display tends to slow down when one or more notes are sounding. This is because the DJ-70's central processor, which is controlling both the sound and the visual display, is giving first priority to responding to incoming MIDI data and maintaining the sound quality.

Patch Priority

This Parameter, if turned On, will override the normal "voice-stealing" algorithm of the DJ-70. The DJ-70 normally works on a last-note priority basis. It is not impossible, especially when it is being used multitimbrally, to use up all of the DJ-70's 24 voices, especially if one or more of the voices are layered from multiple Samples. If at any time all 24 voices are in use, and a new note is struck, the note that has been sounding the longest will lose one or more voices to accommodate the new one(s). However, if that oldest-living note belongs to a Patch with Priority turned On, it will

not give up any voices, but will continue to sustain. The next-oldest-living note will be asked to give up voices for the newcomer.

In normal practice, Patch Priority should be turned on for sustained lead lines and held bass notes (if it is needed), and off for background tracks and drums. Note that if all Patches in a performance have Patch Priority turned on, the DJ-70 will operate on a first-note priority basis, and any new notes that exceed the 24-voice limit will be ignored.

Offsets

Cutoff Offset is a bias control that acts on the TVF (Time Variant Filter) in all of the Partial that make up the Patch (see next chapter). The range is -63 to +63. Positive values will make the sound brighter by raising the filter's cutoff frequency, and negative values will make it duller, by lowering the cutoff frequency. Play with this Parameter in the current patch and see how the tone is affected.

Vel-Sens Offset is a bias control that acts on any parameters that are programmed to respond to MIDI velocity, such as the TVF (for brightness) or the TVA (Time Variant Amplifier, for volume), or an envelope's speed. The range is -63 to +63. Positive values increase the effect of velocity, while negative values dampen it. When a patch is automatically created by the DJ-70 this parameter is set to -63.

Tuning

Oct Shift changes the position of the Patch on the keyboard up or down one or two octaves. Another way of looking at it is that it transposes the MIDI data going to this particular Patch by an octave or two. It not only alters the pitch of all of the Partial (relative to MIDI note numbers), but it also moves the Splits up and down (we'll get to Splits in a moment). For example, if a particular Partial is assigned to the octave C₃ to C₄, setting Oct Shift to 1 will move that Partial to the octave C₂ to C₃.

Oct Shift is useful for adjusting the ranges of Patches within a Performance, and makes it easy to set up two Patches to double at the octave, or conversely, to make a unison out of two simultaneous-sounding Patches that are sounding an octave apart. Different Patches in this Volume use different Oct Shift settings, and you can hear that they play in different ranges.

Coarse Tuning adjusts the pitch of the entire Patch in semitone steps, up or down over a range of 48 semitones (4 octaves). If a note is sounding when you change this Parameter, the note's pitch will change. Note that Samples have an upper limit beyond which they cannot be transposed higher (normally two or three octaves above their original pitch, depending on the sampling rate), so after a certain point, this Parameter will not do anything.

Unlike the Oct Shift parameter, this Parameter does not move the Splits. Using our previous example, setting Coarse Tuning to 1 would leave the Partial in the original octave C₃ to C₄, but those notes would sound a semitone higher.

Fine Tuning adjusts the pitch of the Patch in cents, or hundredths of a semitone. The range is ± 50 cents, or 1/4-tone up or down. You can adjust this Parameter and hear its effect while a note is sounding (which makes it a whole lot easier to use!).

The Tuning Parameters have many uses, including bringing different musical sounds into tune with each other, and creating harmony, doubling, or chorusing effects. Sounds can be tuned at the Partial and Sample levels as well.

Analog Feel is a pitch randomizer, which causes each occurrence of a note in the Patch to play at a slightly different tuning. Used subtly, this can be very helpful in making a performance sound more “live”. The range is 0 to 127, with the highest value causing the pitch to vary up to a semitone above or below the nominal pitch. If a Patch contains more than one Partial, the randomization operates independently on each Partial, detuning them not only relative to other Patches, but relative to each other as well, so that flanging and chorusing effects can be created. Pitched instruments, especially woodwinds and vocals, work best with small values. Unpitched instruments, like drums, work well with larger values.

Pad Key parameter is the note number used for the patch when the patch is played using one of the 8 pad.

Scratch Key parameter is the note number used for the patch when the patch is played using the scratch dial.

Scratch sens parameter modifies the patch sensitivity of the scratch wheel. Using values close to zero, the speed of the wheel does not move the pitch of the patch, using values close to 100 the speed of the wheel moves the pitch of the patch.

Pitch mode parameter can be set to “DJ-70” or “S-770/750”. If set to DJ-70, assigning a patch to a keyboard range, the lower key of the range assigned is considered as original key, if set to “S-770/750”, the keys of the keyboard assigned to a patch are sent as real key number.

Splits

The second Page of the Patch Function is Edit Patch Split. On this page, Partials are laid out across the MIDI keyboard in regions called Splits. A Split can be as narrow as one note, and as wide as 88 notes (the range of the DJ-70). A Patch can contain just one Partial as when automatically created, or as many as 88. Splits cannot overlap (if you want to overlap sounds on a keyboard, you can do it with Patches at the Performance level - see Chapter 8). However, the same Partial can be assigned to different, non-contiguous regions of the keyboard. Not every note on the keyboard must be part of a Split, and any notes that are not assigned to a Split will make no sound.

Multisampling

Splits are used for several purposes. When you are trying to reproduce the sound of a natural instrument that covers a wide range, one Sample of the instrument rarely will be sufficient. A Sample that is transposed too far up or down from its source pitch often will suffer from the “chip-

munk” effect - the formal technical name for this is “munchkinization” - in which it sounds like a tape recording of itself being played at the wrong speed (which is essentially what is going on, although there’s no tape involved).

The transposing distance you can get away with from a single Sample will vary widely depending on the nature of the Sample: a grand piano, with its rich, out-of-tune harmonics, will start to sound unnatural if you transpose it more than about a minor third (three semitones); while a vocal “ooh” Sample can sometimes be transposed an octave or even more before it sounds strange. Samples generally transpose downwards better than they do upwards, and in some cases, with low-pitched Samples, you can safely do very large downward transpositions. The DJ-70 will not let you transpose a Sample up more than two (or three if it was sampled at a low rate) octaves. (If you really need to do so, however, you can transpose as much as you want with the Rate Convert or Resampling functions).

Therefore, a technique known as “Multisampling” is used with many sounds, in which a different Sample is taken at regular intervals up and down the scale. In the DJ-70, each of those Samples is put into a Partial, and then the Partials are mapped across the keyboard using the Edit Patch Split page.

Because you can usually transpose a Sample down further than up, the original pitch of a Sample will typically be mapped at or near the top of a Split range - for example, a Sample of a piano playing E5 may be assigned to the notes from C#5 to F5, and another Sample of the piano playing A5 will then be assigned to the notes F#5 to A#5, and so on.

When a Sample is recorded, it has an “Original Key” parameter, which usually corresponds to the pitch of the Sample - for example, if a sound at 440 Hz is sampled, its Original Key would normally be set to “A_4” (A above Middle C). If the Original Key does not match the pitch, then when you place the Sample (actually, the Partial containing the Sample) into a Split, it will be way out of tune, and will suffer from munchkinization. You cannot adjust the relative pitch of a Sample within a Patch - you can only adjust the tuning of the Patch as a whole - but you can do it at the Partial level (next chapter).

Drum and effects mapping

Another reason for using Splits is to be able to play totally different sounds from different notes within a Patch. A common example of this is a drum set, in which each note plays a different drum. Another example is a set of sound effects residing in RAM, which are called up using a MIDI sequencer locked to SMPTE timecode on a videotape. Each sound effect can be assigned its own note, so getting one to fire at the proper time is merely a matter of telling the sequencer to play its note at the prescribed SMPTE time. (In both of these instances, you don’t want the actual note number to change the sound’s pitch, so the K.F [Key Follow] parameter on the Partial Common page for that Sample should be set to Off. But that’s the next chapter.)

Examining the Split

The Split page gives other important information about each Partial in a Patch. This includes the Samples (up to four) that are in each Partial, and the overall Key Range for that Partial. If

the Partial is mapped to two or more non-contiguous regions in the Split, only one key range will be displayed: from the lowest note of the lowest region to the highest note of the highest region. The (Info) line says “Partial for SET”, meaning that the information being given is for the Partial named in the Partial parameter, close to the Set switch.

There are various ways to look at how the Partials are laid out in a Split. As described above, you can scroll the Partial parameter to see where the Splits are. Note that there is a Select Icon next to the word Partial. Select it, and you will open a Select window from which you can choose any Partial in RAM, and see if and where it belongs in the current Patch - areas of the keyboard assigned to that Partial will show a dark area in the horizontal bar above the keyboard graphic.

Additionally, you can use your MIDI keyboard. Playing a note that is assigned to a Partial will display the note on the keyboard graphic on the screen, and will also change the Info in the graphic and above it to correspond to the Partial being played (regardless of where the cursor is). If you play an unassigned keyboard key, the display will not respond.

Designing the Split

The way to decide the split is to use the Partial parameter and the S1 or S2 buttons to select the Partial you want to assign to a region of the keyboard. We'll look at the Patch we've just loaded as an example.

Using Parameters

The method for designing a Split is to select a Partial and set its range using the Upper and Lower parameters. They can be adjusted with the S1 or S2 buttons or VALUE wheel. The lowest note you can use is A_Ø (21) and the highest is C_8 (108). Note that these parameters are inclusive, which means that the low- and high-limit keys are included in the Split. If you set both limits to the same note, the Split will consist of only that note. When you confirm on the Set switch, the Partial assignment goes into effect.

Now let's design a new Split for this sound. Set Upper to B_5 and Lower to G_5. put the cursor on the Set switch and confirm pressing S1 or S2 buttons. You'll see a new red area appear in the bar far up the keyboard. If you play any of them on the keyboard, or via MIDI, you'll hear the sidestick sound. (The pitch doesn't change because this Partial has its Key Follow parameter turned off.) Notice the original Split is still in effect.

Try this with other Partials in the Patch, assigning them to different regions. Set the limits and the Partial, and select “Set”. If you assign a Partial to a note that has already been assigned, the latest assignment will take precedence. For example, if you set a partial to D#5 and F#5, and then set another partial to F5 and G#5, the result will be that the first partial sound will be heard on D#5 and E5 only, and the other partial sound will start at F5.

To remove one or more notes from a Split, set their lower and upper points and assign them to a different Partial or, if you want nothing to sound on those notes at all, set the Partial parameter to “—Off—” and assign them to that. (You could also assign them to an unused Partial, but that would be dangerous if you used that Partial slot later on.)

Try these techniques with some of the existing Partials. If you really screw things up, remember that nothing is permanent on the DJ-70 until it gets saved to disk, so feel free to re-load the original version of the Patch whenever you want, and you can wipe out all your experiments. If you want to save them, feel free to do that as well (using the Disk Save page), only be sure to change the disk set in which you save the patch.

You can also assign a split using the keyboard:

- Select the partial to assign
 - Press and hold the Sample Start/End button
- On the LCD the message “**Set from Keyboard/MIDI**” will appear
- Press the key on the keyboard that you want assign to the current split
- In the graphic LCD Display a dark rectangle will appear indicating the keyboard area assigned to the split.

Assignment Types

The Assign Type parameter determines how a Split will respond to multiple MIDI notes. There are three main types.

Poly is the normal, polyphonic mode. It is the default mode.

Mono is a special mode which normally behaves like Poly, except when you play the same note twice. If the note has a long envelope (TVA) release, or if you are holding the Sustain pedal, you will hear the note cut off and be re-triggered. It can be used for that well-known st-st-st-stuttering effect. On the other hand, if a sound has a fast release, playing it in this mode will not sound much different than Poly mode.

Exc (it stands for “exclusive”) is an expanded version of what you might normally think of as Mono mode: notes within a Split of this type can only sound one at a time. However, there is not just one Exc mode - there are 16 of them, and each one is independent of the others. So you will be able to play only one note within a Split whose Type is Exc1, and only one within a Split whose Type is Exc2, but you can play those two notes simultaneously.

Another way to set up a Split might be to simulate a saxophone, using a number of Samples (ranging all the way from Bass Sax to Soprano Sax), but all assigned to a single Exc group, so that only one note can sound at a time.

There is no “Off” mode in Type Assignment. If you wish to remove a region from an Exc group, make it Poly. Do this by selecting an adjacent Poly region and expand it into the Exc group as far as you need. If there is no adjacent Poly region adjacent to a group you wish to shrink, you’ll have to do it the old-fashioned way, setting the Upper, Lower, and Assign Type parameters by hand.

Renaming Partials

Once you’ve finished designing a Split, you can change all the names of the Partials in it to the same name as the Patch itself, with various suffixes. This can help quite a bit to keep things organized when you’re working with lots of Partials. More on this at the end of this chapter.

MIDI Control

The DJ-70 allows much in the way of real-time MIDI control over various sound functions. This control is set up on the third Patch-editing Page, Edit Patch Ctrl. These MIDI assignments work globally on all of the Partials in the Patch.

Controllers and controllers

Before we go any further, let's distinguish between a MIDI Controller (upper-case "C") and a MIDI controller (lower-case "c"). The distinction is subtle, but important. In this manual, upper-case Controller refers specifically to one of the 121 Continuous Controllers defined in the MIDI Specification. These include Modulation Wheel (#1), Breath Control (#2), Volume (#7), Sustain pedal (#64), Registered and Non-registered Parameters, unassigned Controllers, etc. etc. Lower-case controller refers to any MIDI message that contains data which can change over time, which includes all the Controllers, plus Pitch Wheel, Channel Pressure (also known as monophonic aftertouch), and Key Pressure (polyphonic aftertouch). So "Controllers" is a subset of "controllers".

And just to make things more complicated, "MIDI controllers" (lower-case again) can also refer to a MIDI performing device, like a keyboard, drum pad, guitar, wind controller, etc. Fortunately, this usage will be obvious in context.

The Parameters

Back to our Display. On the top line, as usual, you select the Patch you want to work on. On the second line you can select the MIDI channel the DJ-70 will respond to, but the setting is not completely straightforward, so best to leave it on Omni for now.

Sample Shifting

SMT Ctrl Sel stands for "Sample Mix Table Control Selection", and SMT Ctrl Sens stands for "Sample Mix Table Control Sensitivity". The Sample Mix Table is a feature of each Partial (that's right - next chapter), which allows velocity-based switching and crossfading between two or more Samples in a Patch - so that hitting the note harder not only changes the volume, it can also change which Sample is playing. These parameters allow this Sample-changing feature to be controlled not only by velocity, but also by a MIDI controller (that's the lower-case "c"). That way the MIDI controller can act as a real-time "fader" between the sounds, changing the sounds after the key is struck which is, of course, impossible to do with velocity, since any single note only gets one velocity value.

There are four choices (besides Off) available for SMT Ctrl Sel: Bend (Pitchbend), A.T (Aftertouch), Mod (Modulation Wheel, Controller #1), and Ctrl (a Controller number to be named later). The Sens parameter determines how much influence this control will have over the SMT. The range is -63 to 63. At 0, it will not affect the SMT at all. At positive values it will add to the velocity, and at negative values it will subtract from the velocity.

The controller doesn't replace the velocity control over the SMT, but it does "bias" it, by adding (or subtracting, if the Sens parameter is negative) its own current value to the velocity. For example, if SMT Ctrl Sel is set to Mod and Sens is set to 63, and you move the modulation wheel to its full-on position, the effect on the SMT will be as if there are no velocities being produced below 63, and only the Samples mapped to the upper portion of the SMT (above 63) will sound. If Sens is set to -63, then the effect will be as if no velocities are being produced by the keyboard higher than 64 - that is, 127 (maximum MIDI velocity) minus 63.

Stalking the Wild Controller

The next Parameter on the page is Ctrl Select, and this is the previously-mentioned "Controller to be named later". The DJ-70 responds to Pitchbend, Aftertouch, and Modulation Wheel in fairly normal ways, plus one other "wild" controller per Patch. This parameter determines the nature of the "wild" controller. It can be any MIDI Controller number 0 to 95 (higher Controllers are reserved for System Mode messages). This controller can then be assigned to any of a number of parameters, including SMT Ctrl Sel.

Note that this Parameter only affects this Patch, and other Patches - even if they're used at the same time in a Performance - can have different wild controllers, which can give you a lot of flexibility.

Pitchbend

Bend-Up and -Down are the range, in semitones, of the Pitchbend control for this Patch. They can be set anywhere from 0 to 48 (four octaves). Remember that Samples in the DJ-70 cannot be transposed more than two or three octaves up from their original pitch, so extreme settings for Bend-Up may not give you quite the results you expect. If you want to use the Pitchbend control for something other than pitch bend (such as SMT control), here's where you can turn it off.

The controller Matrix

At the bottom of the page is a matrix of MIDI controllers and the possible effects they can have on the sound. Across the top of the matrix are the controllers, which are the same as the ones available for SMT Control: Pitchbend, Modulation Wheel, and the Wild Controller. Aftertouch in this case can be either monophonic (Channel Pressure) or polyphonic (Key Pressure), depending on the settings of the MIDI Filters, which are discussed in Chapter 8. At the left side are the "Control Destinations".

The Control Destinations are discussed in detail in the next chapter (except Pitch Ctrl, which is easy).

Pitch Ctrl - what the Pitch Wheel normally does, you can also do with Aftertouch and the wild controller. Letting Aftertouch do small amounts of pitch changing gives you real-time "finger vibrato" (and using polyphonic Aftertouch, so you can do it on a note-by-note basis, is particularly cool).

TVF Ctrl - this increases or decreases the effect of the Time Variant Filter, which we met earlier when dealing with the Cutoff Offset parameter on the Common page. It essentially controls the Patch's brightness.

TVA Ctrl - increases or decreases the effect of the Time Variant Amplifier, or volume envelope, which we also met on the Common page. This essentially deals with overall volume. (Note, however, that MIDI Controller #7 - Volume - is always responded to by the DJ-70.)

LFO Rate Ctrl - influences the vibrato rate(s) of the various Partials. Each Partial has its own vibrato rate, and this will increase or decrease all of them at the same time (but it will not make them all the same). The vibrato LFO can be set to change pitch,

This mapping lets Foot Pedal control the brightness while Aftertouch imparts a bit of vibrato onto the timbre. (Set Ctrl Select to 4.)

Controller	Target	Setting
Ctrl	TVF Ctrl	63
A.T	LFO-TVF Depth	25

This mapping brightens the timbre of a sound when you apply Aftertouch - sort of a finger-pressure wah-wah effect - and at the same time reduces any pitch vibrato already on the sound.

Controller	Target	Setting
A.T	TVF Ctrl	63
A.T	LFO-Pitch Depth	-20

Combining controllers

If more than one controller is mapped to a Control Destination, they will both be operable. However, if you send data from two controllers that are mapped to the same Control Destination at the same time, what happens is not what you might expect. Instead of the last controller event being the operative one (which is how MIDI deals with the world), the two controllers work together, and their values are added together to determine the effect on the Control Destination.

The "Part" Parameter

The Part parameter on the Patch Common page is used primarily when working on Patches within a Performance, and it will be discussed in that context in Chapter 8. It serves as a kind of MIDI channel filter. Normally speaking, it will be set to Omni. This means that the Patch on display will respond to all MIDI data coming into the DJ-70, on all channels.

When you're playing the Patch from a keyboard, this is fine. But what if you are working with a sequence, which has data on several MIDI channels at once, and you want to edit the Patch? If you just go to this page as it is, the Patch will respond to every incoming MIDI note, which would be awfully confusing. You can filter out the unwanted tracks by changing the Part parameter.

When you set Select/MIDI in to Part 1, the DJ-70 no longer responds on all channels, but instead only responds to data on the MIDI channel which is assigned to Part 1 in the current Performance. The current Performance is the Performance that was displayed the last time you

accessed one of the Performance pages. If you haven't accessed a Performance page since boot-up, the current Performance is the default Performance.

A Performance contains up to 31 Parts. In the default Performance, all the parts are set to the Basic MIDI channels.

Other Patch Functions

Several other functions that affect Patches are available through the Com menu on any of the Patch Edit pages.

Disk

The Disk function (Load A, Load B, Load A/B, Save, Util) is the same as in other modes and is described in Chapters 3 and 9. When you Load a Patch, it loads in all subsidiary Partials and Samples, unless you set the Target to Patch PRM, in which case it loads in the Partials, but not the Samples. This way an existing Patch can easily be used as a template to organize a different set of Samples.

When you Save a Patch, any new Samples or Partials you have created get saved with it. In addition, any old Samples or Partials that are subsidiary to the Patch will be saved.

Copy

Copy lets you make a duplicate of the Current Patch into another slot in RAM. This allows you to make multiple clones of a Patch easily which can then be edited individually, or to allow you to keep the original version of a patch safe while you edit it.

To make a copy of the Current Patch, choose a slot to copy into from the Copy window.

The duplicate has two letters added to its name: the first copy will have "AA" tacked onto the end; the second will have "AB", etc. You can freely copy copies, and the alphabetic progression will continue regardless of whether you are copying an original or a copy.

If the slot you are copying into is occupied by another Patch, that Patch will be deleted. If the slot is occupied by another copy of the Patch you are copying, the name will not change - that is, a new suffix will not be assigned. Any of these copies can be saved to disk, modified or unmodified.

Delete

The Delete function on the Com menu lets you select a Patch to remove from RAM. It is useful when you want to clean up RAM prior to saving a Volume (Chapter 8). The Delete function only works on RAM - the files on disk are not changed unless you go through the Disk function.

As you pass the cursor over the names of the Patches in the Delete window (without confirming), you can hear each one if you play the keyboard. This can help you determine which Patch you want to lose.

Files at the bottom of the list (higher numbers) will delete faster than those at the top, so if you're deleting a lot of Patches at a time, it's best to start at the bottom and work your way up.

Initialize

Initialize sets the current Patch to an initialized state: all Parameters are set to their default values, and all Splits are cancelled. It does not remove any subsidiary files from RAM, it simply erases their assignments as far as the current Patch is concerned. You are given a warning window before the Initialization takes place.

Rename Partials

This function renames all of the Partials in the Current Patch to the same name as the Patch, and adds a suffix. The lowest-placed Partial gets the suffix "AA", the next lowest "AB", and so on. (If any suffixes are in use because of a previous Copy operation on a Partial with the same name, the software will start assigning them with the first one available.)

The main use for this function is when you need to create a new version of an existing Patch in which the Partials are modified. Remember if a Partial belongs to more than one Patch, editing it changes it for every Patch. So, for example, if you have a fast-attack string Patch, and you want to create a slower-attack version without losing the original, you can Copy the Patch, change its name, and then select Rename Partials. Now you have a whole new set of Partials whose envelopes you can edit, without affecting the envelopes of the Partials in the original Patch. This doesn't use up any additional RAM or disk space, because the Samples are unchanged.

Partial Map and Edit Partial - Moving on Down

These two commands let you move down to the Partial Edit level and work with one or more Partials that are associated with the current Patch. Getting to the Partial level this way ("Subsidiary mode") is not exactly the same as getting to it from the Sound menu, and there are certain extra features and restrictions that come into play. They are discussed in detail in the next chapter. When you Exit the Partial level, you will come back up to the Patch Edit level.

The Patch Map

The Patch Map provides another way of viewing and adjusting many of the Patch parameters - from another dimension, you might say - from within a Performance. Rather than looking at a group of parameters for a single Patch, you get to look at the settings for a single parameter on all Patches within a Performance, simultaneously. The Patch Map page is accessed at the Performance Play level. We will discuss this more in Chapter 8.

Chapter 5:

Partials

The next layer below Patches in the DJ-70's operating system are Partials. A Partial consists of between one and four Samples, along with information about how they are to be played. This includes level, tuning, pan position, velocity switching, LFO (vibrato) action, and envelopes, both volume ("TVA") and filter ("TVF"). One or more Partials are arranged across the MIDI note range to form a Patch, as we saw in the previous chapter.

Partials are constructed and edited on the Edit Partial pages, of which there are five. There are several ways to reach these Pages:

- select **Edit Partial** from the **Sound** menu,
- select **Partial** from the **Index**, and **Partial Common** from the subtopic window,
- select any of the possible topics in the **Index** that apply to the Partials pages (**Amp, Filter, LFO, Output, Panning, Pitch, Velocity**) and then selecting the appropriate subtopic (for example, **Partial TVA**) from the menu that appears,
- use a Jump page that has been previously programmed
- or go through any of the Patch pages. You move from a Patch page by opening the Com menu, and then selecting Edit Partial. When you call up a Partial page from a Patch page, it's in Subsidiary mode, and the Partial page behaves a little differently, which we will explain later in this chapter. (The Jumps in fact go through the Patch pages.)

In addition, there is another set of pages for editing Partials called the Partial Map, which we will also deal with later in the chapter.

When you Exit a Partials page, you will go back to the Page or window you came from: either the Sound menu or the last selected Patch page.

Playing Partials from MIDI or Keyboard

The Partial pages normally respond to MIDI in Omni mode, so no matter what channel your MIDI keyboard is transmitting on, the DJ-70 will respond (although this is not necessarily true in Subsidiary mode, which we'll get to at the end of the chapter). The MIDI controller functions (LFO response, pitchbend range, etc.) are determined by the settings made on the Edit Patch Ctrl page of the last Patch to be loaded or edited or, if there has been no Patch loaded or edited since you booted up, the default settings will be used (LFO-Pitch Depth under A.T set to 35 and under Mod set to 30; all other parameter sensitivities set to 0; SMT Control Off; and Bend-Up and —Down both set to 2).

Let's prepare for this chapter by loading one more Partial into RAM. Go to the Disk Load page (through the Disk Button), and set Target to Partial (not Partial PRM). Then load a partial.

When you are asked to clear Internal memory select No.

Press the Exit button to get back to the Partial pages.

Basic Parameters

The first page, Edit Partial Common, is where the basic parameters for constructing the Partial are set up. At the top of the page is the name of the current Partial - if you are creating a Partial from scratch, this line will be blank. Next to it is a “Name” box: select this and the ASCII window appears and you can rename the Partial. The second line, Edit Mode, will normally be set to “Single”. At the bottom of the Lcd Display, as on the Patch Common page, the Used parameter refers to the amount of sample memory in the current Partial, while the Remaining parameter refers to available memory in RAM.

Remember that if you alter a Partial that is being used in more than one Patch, the alterations will affect the Partial wherever it’s used. If you don’t want this to happen, copy the altered Partial before you edit it (use the Copy function described at the end of the chapter).

Putting Samples into the Partial

The lines labelled “1” through “4” are the four “slots” for Samples that can be combined to form this Partial. Move the cursor keys so that the first line is highlighted, and then use the value wheel or the S1 and S2 buttons to scroll through the available Samples, or put the cursor and confirm on the Select icon to the left of the Sample number to open the Select window. Any of the Samples currently in RAM (that is, any Samples that have been loaded in by themselves, or as part of another Partial, a Patch, a Performance, or a Volume) will be available. The same Sample can appear in more than one slot. To get an idea of how Partials use combinations of Samples, scroll through the ones you’ve just loaded in.

Stereo Samples require two slots. You can enter the two halves of a stereo Sample individually, but there is also a shortcut. Next to the Select icons for slots 1 and 3 is a blue “[*]”. Putting the cursor on this and pressing the S1 or S2 button scrolls the Samples in RAM but ignores all the mono ones. Instead, it finds the next stereo Sample, and enters its two halves into the chosen slot and the slot directly beneath it. (It also does more than that, which we’ll get to in a moment.)

The number of Samples in a Partial determines the number of DJ-70 “voices” that will be used when the Partial - or a Patch containing the Partial - is played. The DJ-70 has a limit of 24 simultaneous voices, and Partials with multiple Samples will use those voices up more quickly than single-Sample Partials. However, as we shall see, multiple-Sample Partials don’t always use all their voices all the time. (See also the discussion of voice-stealing in the previous chapter under “Patch Priority”.)

Tuning Individual Samples

Each Sample can then be tuned individually, relative to the overall Partial tuning. C.T is

coarse tuning, and has a range of ± 4 octaves in semitone increments, while F.T is fine tuning, and has a range of \pm half a semitone (a quarter-tone), in increments of 1 cent (1/100th of a semitone). The entire Partial can also be tuned, using the Tuning Parameters at the bottom of the screen, which we'll discuss in a moment.

This is the best place to tune a Sample that was recorded with an Original Key parameter that does not reflect the Sample's true pitch (we discussed this in the section on Multisampling in the previous chapter). If the Parameter and the pitch don't match, then when you place the Sample (actually the Partial containing it) into a particular keyboard range as part of a Patch Split, the pitches that sound will be different from the notes you play. This can be corrected with these Parameters.

Another use of these Parameters is to create tuned layers within a Partial. For example, you could load the same sample into two slots, and then detune one slightly (change F.T up or down by 4) for a flanging or chorusing effect, or detune one by an octave (change C.T by 12) for a dramatic doubling effect. (Remember that the Analog Feel parameter on the Patch Common page randomly detunes each Sample in the Partial independently.)

Transposition Limits

Samples in the DJ-70 can only be transposed a total of two octaves above their original pitch (three if they were recorded at a low rate), whether that transposition is done by incoming MIDI data, or by a re-tuning of the sound at the Partial or Patch level. If you try to transpose a note higher than that - for instance, if you try to play a four-octave scale up from the original pitch - when you reach the two- or three-octave limit, the note will continue to play, but the pitch will not go any higher.

Therefore, if you layer two Samples in a Partial and one of them has been transposed up by a large amount, when you play the Partial up the scale, at one point the pitches will stop being an octave apart, and one of them will "freeze" while the other continues to go up. This can be avoided by making sure the Split range (at the Patch level) for that Partial doesn't go so high that one of the Samples is being transposed up more than the two- or three-octave limit.

Changing the Scale

K.F, or Key Follow, lets you change the scale of the Sample relative to incoming MIDI notes, by "stretching" or "shrinking" it. When K.F is set to Norm, the Sample plays normally, i.e., moving a semitone up on the keyboard raises the Sample's pitch by a semitone. When it is set to one of the ratios, which range from 1/8 to 16/8, the scale is changed by that ratio.

For example, if the ratio is 16/8, playing two keys a semitone apart will result in two notes sounding a whole tone apart; playing two notes a minor third (three semitones) apart will sound a diminished fifth (six semitones); and playing two notes an octave apart will result in two notes two octaves apart. Going the other way, if the ratio is 1/8, a semitone on the keyboard will result in a pitch change of only 1/16th-tone, while a minor sixth (eight semitones) on the keyboard will sound a semitone. A two-octave spread will sound a minor third. (You will notice that Norm is equivalent to a ratio of "8/8".)

Negative ratios are allowed, which make the pitch go down as you move up the keyboard and vice versa. The “zero point” - the key which the ratios are calculated from - is the Orig Key set in the Sample itself (see the next chapter). If the Orig Key is F₄, playing F₄ will always result in the same pitch, regardless of the K.F setting (although it may not actually be a G#, because of the setting of the Tune parameters). There is also an Off position for this parameter, which makes the Sample always play back at the Orig Key pitch regardless of which key is being played. This is useful for mapping drums and other sounds that you may want to use on more than one key without having their pitch change.

The “spread scales” that result from various settings of the K.F ratio are good for simulating non-Western ethnic music, or creating or modifying non-musical sound effects. Try setting up 1/8 or 2/8 ratios on some of the drum sounds in RAM, or on the vocal sounds for a Ligeti-like effect. When constructing a soundtrack, playing an ambient sound on several keys pitched a fraction of a semitone apart can create a thicker ambience, with varied loop times, without imparting any unwanted “pitchness” to the sound.

Small K.F ratios are also useful when working with sounds which have an “unpitched” and a “pitched” portion, like a breathy flute, a guitar with string-sliding noises before the note, or a spoken word. By putting the different portions in different layers in the Partial, and giving the “unpitched” portion (the breath, the slide, or the consonant) a small K.F ratio, so it stays relatively constant in pitch as the rest of the sound moves up the scale, you can make the sound much more natural.

Partial Level lets you set a general level for the Partial (from 0 to 127) as it appears at all of the outputs (numbered and stereo) to which it is assigned.

Panning refers to the stereo outputs, and sets the pan position of the Partial as a whole, from L 32 (hard left), to Ø (center), to R 32 (hard right). The individual Samples get Pan positions too, on the next page, SMT, and if the Samples are set up with pan positions (for example, if they are halves of a stereo pair), this control acts as a “bias”, moving the overall stereo image left or right, but not collapsing it into mono.

Other Parameters

Coarse Tuning and Fine Tuning (the ones in the lower half of the LCD Display) adjust the tuning of all of the Samples in the Partial simultaneously. They do not override the C.T and F.T parameters for the individual Samples, but instead add to (or subtract from) those settings.

SMT Velocity Ctrl enables the Sample Mix Table, which is on the next Page (and coming right up) to be controlled by velocity. When it is Off, all four Samples will maintain the same relative balance to each other, regardless of the velocity. However, they can still be controlled by the SMT Ctrl set at the Patch level, described in the previous chapter.

SMT

The Sample Mix Table (SMT) page allows you to balance the Samples that make up the Partial in several different ways.

Panning and Level

As on the Common page, the top line of the Edit Partial SMT page shows the name of the current Partial, and the first four lines below that show the names of the Samples. You can select which Samples will be included in the Partial on this page as well as on the Common page; any changes made here will appear on the Common page and vice versa.

The Pan parameter allows each Sample to be located spatially in the stereo outputs. The range is from hard left (L32) to center (Ø) to hard right (R32). If you are using a stereo Sample, you would normally select the two halves of the Sample (which bear the suffixes “-L” and “-R” in their names), and pan one to L32 and the other to R32.

This parameter can be influenced, and the stereo field for the Sample shifted one way or the other, by the Panning parameters on the Partial Common and Patch Common pages.

When you enter a stereo Sample into a Partial using the [*] function on either the Common or SMT page, the Pan parameters of the two halves of the Sample are automatically set to L32 and R32, respectively. After the Sample is entered, the Pan settings can be changed, if you like.

Samples recorded in stereo are not the only Samples that can have stereo characteristics. It's quite possible to take two unrelated sounds and set them up on opposite sides of the stereo field, or to take two identical sounds and, by changing one slightly and panning them to opposite sides, “synthesize” a stereo sound. We'll get to an example of this in a moment.

You can also create a stereo image from a single Sample using the three other options for this Parameter. Rnd randomly places each individual note in the stereo field as it sounds, Ky+ places the sound according to the MIDI note number, with lower notes on the left and higher notes on the right. Ky- reverses the process, and places the higher notes on the left and the lower notes on the right.

The Level parameter (adjustable from 0 to 127) allows you to adjust the volume of each Sample individually, so you can balance them.

Velocity Switching

The bottom half of the SMT page is used to set up velocity-based switches and crossfades for the various Samples within the Patch. Velocity switching allows different Samples to sound depending on how hard a MIDI key is hit.

Another use for a velocity switch would be a sax Sample: at lower velocities, you use a mellow tone, while higher velocities call for a more strident sound. You can also set up velocity switches so that more Sample layers are added as the velocity increases, providing not only a louder sound, but also a brighter, thicker, or more complex sound at higher velocities.

Each of the four Samples can be assigned a velocity range within which it will respond. If a velocity level is received that is below the Vel Low level or above the Vel Hi level for a particular Sample, that Sample will not sound. Note that this range does not change the velocity response, it simply limits it. This means that regardless of whether the Vel Low level for a Sample is 1 or 74, a

MIDI note-on with a velocity of 75 will always play that Sample at the same volume. But if the Vel Low setting is 76, a MIDI note-on with velocity 75 will make no sound at all.

The window at the bottom of the screen shows the velocity ranges of the four Samples as horizontal lines, each three pixels high. (If a Sample slot is “Off”, its line will be only one pixel high.) When you select any parameter relating to one of the four Samples with the cursor keys, the horizontal line corresponding to that Sample will be highlighted.

The window also displays an arrow showing the velocity of the last note-on played. As you play the keyboard and listen to the sounds, the arrow will jump around. This can be a big help in determining how to set up your velocity range values.

You can adjust the Vel Low and Vel Hi levels for each Sample by selecting the individual parameter and incrementing or decrementing it with the S1 and S2 buttons or the VALUE wheel.

Velocity Fading

A transition between two velocity-switched Samples can be made smooth by overlapping their velocity ranges. But for even more smoothness you can “fade” the Samples into each other. The Fade L(ow) parameter for each Sample in the Sample Mix Table sets a range of velocities, above the Vel Low value, over which the sound will fade in as the velocity increases. This means that an incoming note with a velocity of 71 will sound that Sample at minimum volume, and as the velocity rises from 71 to 90 (71 + 19), the volume will increase relatively sharply. At 91 and above, the velocity response is linear all the way up to 127. It could be said that the Fade L parameter scales the bottom of the velocity response curve for a particular Sample.

The Fade H(igh) parameter does a similar thing with the Vel Hi parameter - it sets a range of velocities over which the volume of the Sample will decrease as the velocity increases, with the Vel Hi parameter as its upper limit, at which point the volume will be at minimum. Sample 1 (the “ride” sound) illustrates this: Vel Hi is 109 and Fade H is 19. Therefore, velocity response will be linear up to 90 (122 - 11), and then notes will get progressively softer as the velocity increases to 109. When the velocity is above 109, the Sample won’t sound at all.

The combination of limits and fades can give you very complex switching algorithms. Also keep in mind that the SMT Ctrl that you selected at the Patch level will also act on these functions, not by increasing or decreasing the actual velocities (or the volumes), but by shifting the break points of the switches up and down. (More on this in a moment.)

You can adjust the Fade L and Fade H parameters by selecting them and then pressing S1 or S2 buttons or turning the VALUE wheel. Notice that when you set a Fade parameter, the middle portion of the horizontal line representing the Sample you are working on (i.e., the second vertical pixel) moves away from the end of the line, creating an “open” line, showing the extent of the Fade.

When you enter a stereo Sample into a Partial using the [*] function on either the Common or SMT page, the Vel and Fade parameters of the right half of the Sample will automatically be set to the same values as the left half. If you like, you can change any of these values afterwards.

Other SMT controls

As we saw in the previous chapter, The Sample Mix Table can also be operated in real time (before or after a note has been played) by a Keyboard or a MIDI controller, such as Pitchbend, Modulation Wheel, or Aftertouch. Therefore, a certain velocity value may cause one Sample to sound, and then by applying aftertouch to the key, a different Sample fades in. The SMT controller doesn't replace the velocity data operating the SMT, but adds to or subtracts from that data, to the degree determined by the SMT Ctrl Sens parameter on the Edit Patch Ctrl page.

TVF

TVF stands for Time Variant Filter. It determines how the timbre of the Partial will change over time, by boosting or attenuating certain frequencies. The filter has two main parts: the Parameters defining the filter itself, and the envelope to control how the filter changes over time. The Parameters on this page can also influence the pitch of the Partial as it plays.

The Parameters

Filter Mode can be set to Low-Pass (LPF) which cuts off high frequencies, and is the most common mode; Band-Pass (BPF) which accentuates a narrow band of frequencies; or High-Pass (HPF), which cuts off low frequencies. It can also be turned Off, which renders everything else on the page meaningless.

Note: If you are not using the filters on a Partial then it is best to leave this Parameter Off (rather than disable them in some other way), because the DJ-70 responds slightly faster when you do this.

Cutoff Freq controls the frequency that the filter's action will take place at - the "knee" of the filter, or when the mode is Band-pass, the center point of the filter's action. Higher numbers are higher frequencies.

Key Follow determines whether the Cutoff Frequency is going to be constant over the entire keyboard range, or whether it will change with changing incoming MIDI notes (this is sometimes called a "tracking filter"). At 0, the Cutoff Frequency will be constant across the keyboard range. At positive values, the Cutoff Frequency will rise as the MIDI note goes up, and the higher the parameter, the steeper the rise. At negative values, the Cutoff Frequency will go down as the MIDI note goes up, so that higher notes contain fewer high frequencies. The range is -63 to +63. The "median" point for the filter - that is, the note at which this Parameter has no effect - is determined by the KF Point at the bottom of the column.

Key Follow can help to make a sampled sound more "natural" - on a real instrument, high notes usually have more high-frequency partials than low notes. Proper use of this filter can extend the good-sounding range of a Sample.

Another important use is to eliminate any high-frequency noise that might have been recorded with the original Sample when transposing it down by a large interval. Any noise that is present

in the original Sample will be transposed down as well, and can sound very ugly. (Although because the DJ-70 uses constant sample-rate playback and differential interpolation, aliasing noise will not be a problem.) By using a Low-Pass Filter whose Cutoff Frequency goes down with the pitch, the noise can be eliminated easily.

Resonance refers to the depth, or “Q”, of the filter action. Low numbers mean the filter will be relatively subtle and broad, while higher numbers mean the filter will be sharper. As with an analog synthesizer, when the Resonance value reaches a certain point, the filter goes into self-oscillation, producing a tone whose pitch will vary with the Cutoff frequency and the filter envelope.

Vel-Curve and C.Sens will be discussed in a moment.

Envelope has three parameters, all of which have a range of -63 to +63:

TVF Depth determines how much the cutoff frequency of the filter will respond to the envelope described at the bottom of the screen. At 0, the filter will remain at a constant frequency and the envelope will have no effect. As you increase the value of the parameter, the cutoff frequency of the filter will change more with the rising and falling of the envelope. At negative values, the cutoff frequency will respond to the envelope “upside-down”: as the envelope rises, the cutoff frequency will fall, and vice versa. If you use negative values in a Low-Pass or Band-Pass filter, you should use a high Cutoff Freq, or you might find everything filtered out.

Vel Sens determines how the filter envelope responds (if at all) to MIDI velocity. At high values of the parameter, high incoming MIDI velocities will make the cutoff frequency more sensitive to the envelope - which means if you hit the note harder, the filter envelope action becomes stronger. At negative values, high velocities will flatten out the envelope, so that as you hit the note harder, the filter action becomes less strong, and soft notes will produce the most change in the filter. A value of 0 means that velocity will have no effect on the filter.

Vel Sens is influenced by Vel-Curve and C.Sens, on the left side of the LCD Display:

Vel-Curve selects from one of four velocity curves which are illustrated below. Curve 1 is a constant value, so that changes in velocity don't affect the filter at all (like setting Vel Sens to \emptyset). Curve 2 is linear, meaning that velocity changes cause filter changes proportionately throughout the velocity range. Curve 3 curves downward, so that velocity changes at low velocities affect the filter less than those at high velocities. Curve 4 curves upward, so that low-range velocity changes will affect the filter more than high-range ones.

C.Sens, which stands for Curve Sensitivity, is set up the same way as Vel Sens, and determines how much, and in which direction, the cutoff frequency will respond to velocity changes. It is not redundant, however, because it is a common parameter for both the Envelope Vel Sens and the Time Vel Sens, described next.

The separate Vel Sens parameters for Envelope and Time mean they can operate independently: setting C.Sens to a positive value and Envelope Vel Sens to a positive value will cause the cutoff frequency to increase with velocity, while at the same time if you set Time Vel Sens to a negative value, it will cause the envelope to slow down as the velocity increases. Admittedly, this

can all get very complicated, but some day you'll thank us for allowing this degree of flexibility.

Time has two parameters, both of which range from -63 to + 63:

Vel Sens expands or contracts the filter envelope in time, according to incoming MIDI velocities. With a positive setting, higher note velocities will cause the filter envelope to act faster, opening or closing in a shorter period of time, while lower note velocities will stretch the envelope out, causing it to open or close more slowly. Negative settings will produce the opposite effect. This parameter is affected by the Vel-Curve and C.Sens parameters.

Key Follow expands or contracts the filter envelope in time according to incoming MIDI note numbers (don't confuse it with the frequency-affecting Key Follow described earlier). With a positive setting, higher notes will cause the filter envelope to act faster, while lower notes will stretch the envelope out, and negative settings will produce the opposite effect. The "median" point, that is, the note which always plays the envelope at its normal rate, is determined by the KF Point parameter.

Pitch Depth has almost nothing to do with the filter, but uses the TVF envelope to effect a pitch change in the Partial as it plays. At 0 there will be no pitch change. At positive values, the pitch change will follow the envelope. As the value increases, the pitch change becomes more pronounced. At negative values, the pitch will follow the envelope upside-down, rising as it falls and vice versa. The pitch change is not affected by velocity, but it does follow any changes in the speed of the envelope dictated by the Time Vel Sens and Key Follow parameters. If the Filter Mode is Off, there is no pitch change.

The maximum pitch change upwards (when this parameter is 63 and the envelope level is 127) is two octaves, while the maximum pitch change downwards (when this parameter is -63) is four octaves.

The Envelope

The envelope changes the Cutoff Freq over time, giving the sound timbral "motion". (The percussive sounds have envelopes that simply open and close with the note-on and -off.)

The envelope itself is a standard four-segment Attack/Decay/Sustain/Release envelope, and a graphic representation of it appears in the window at the bottom of the screen. Time for each segment ranges from 0 (essentially instantaneous) to 127 (up to about 2 minutes). Level for each segment ranges from 0 to 127.

The envelope starts at the level specified under Level 4 when you press the MIDI key (Level 4 and Level "zero" are always the same). During the period specified by Time 1 (the Attack), it rises or falls to the level specified by Level 1. It then immediately goes to Level 2, in the period specified by Time 2 (the Decay), and then to Level 3 in the period specified by Time 3 (the Sustain). It holds at this level until the key (or Sustain pedal, if it's in use) is released - a short line will appear at the right of the square and a vertical line will appear below it and to the right, reminding you that this is the Sustain level (unless Level 3 is 0). When the key is released, it goes to Level 4 in Time 4 (the Release). Like most ADSR envelopes, if the key is released before the envelope has time to play all the way through, it proceeds to the Release segment (4) immediately.

The envelope parameters can be changed by moving the cursor to the desired parameter and pressing the S1 and S2 buttons or moving the VALUE wheel.

The default TVF envelope has all of the Time parameters set to 0 and the Level parameters set to 127 (except Level 4), which means that when you start with a new TVF you will have three squares right on top of each other, and you will only see one. If you adjust the parameters numerically, the squares will sort themselves out.

You've probably noticed another envelope lurking in dark behind the TVF envelope. This is the TVA envelope, which will be discussed next. The two envelopes are always shown together. This can help prevent a situation in which you are gleefully designing a complex filter envelope but somehow it doesn't seem to affect the sound at all, because you've inadvertently made all the filter action take place long after the TVA envelope has shut off the sound. For example, if you were to extend the decay, sustain, and/or release segments of the TVF envelope on one of the percussion Partials, it wouldn't do much.

Note, however, that the diagrams only approximate the real envelope values - because the envelopes can be changed so significantly by velocity and note number, two envelopes that appear similar in length on the screen may end up being very different lengths when you actually play them.

TVA

TVA stands for Time Variant Amplifier, and is the volume envelope for the Partial, determining how the loudness of the sound will respond to MIDI velocities and notes, and how that loudness will change over time. The parameters all behave similarly to their counterparts on the TVF page.

The Parameters

Vel-Curve uses one of the four velocity curves to determine how the envelope (and therefore the overall volume of the Partial) will respond to changes in incoming MIDI velocity. Curve 1 is a constant value, so that changes in velocity don't affect the volume at all, and the Partial always sounds at the same level. Curve 2 is linear, meaning that velocity changes cause proportional volume changes throughout the velocity range. Curve 3 curves downward, so that differences in velocity at low velocities affect the volume less than those at high velocities, and curve 4 curves upward, so that low-range velocity changes do more to change the volume than high-range ones.

C.Sens determines directly how the volume will respond to velocity. At 0, there will be no change in volume with changes in velocity. At positive values, volume will be dependent on velocity. At negative values, volume will respond inversely to velocity, so that higher velocities will result in softer notes.

Key Follow determines whether the volume of the Partial will be consistent over the entire keyboard range, or whether it will change with changing MIDI notes. At 0, the level will be con-

stant. At positive values, higher incoming MIDI notes will play the Partial louder. At negative values, higher incoming MIDI notes will play the Partial softer. The note at which the volume doesn't change regardless of this setting is determined by the KF Point parameter (which, by the way, is independent of the KF Point in the filter envelope).

Time has two parameters:

Key Follow expands or contracts the envelope in time according to incoming MIDI note numbers. With a positive setting, higher notes will cause the envelope to act faster, while lower notes will stretch the envelope out, and negative settings will produce the opposite effect. The “origin” point, that is, the note which plays the envelope at its normal rate, is determined by the KF Point parameter.

Vel Sens expands or contracts the volume envelope in time according to incoming MIDI velocities. With a positive setting, higher note velocities will cause the envelope to act faster, opening or closing in a shorter period of time, while lower note velocities will stretch the envelope out, causing it to open or close more slowly. Negative settings will produce the opposite effect.

The Envelope

The envelope parameters for the TVA are adjusted the same way as the parameters for the TVF, either numerically or graphically. One major difference, however, is that Level 4 (Release level) must always be \emptyset - if it were some other value, the envelope would never shut down and the note would go on forever! This parameter is colored yellow to remind you it's unchangeable. Therefore, the last blue square can only be moved horizontally (Time 4), and the first blue square cannot be moved at all. Similar to the TVF page, the TVF envelope appears in dark blue behind the TVA envelope.

Here's a hint for when you're playing with TVAs and the DJ-70 seems to get stuck: If you set Time 4 on a TVA to a high value and play some notes, the notes may go on for a very long time, even if you change the Time 4 value afterwards (changes in envelope parameters only apply to notes played after you make the change). The screen action, including the movement of the cursor, may slow down considerably, to the point of seeming to stop, as the DJ-70 gives priority to the sound. Don't panic. Just press the EXIT button on the DJ-70 front panel. When everything settles down and shuts up, select where you want to go and resume your work.

Using the Templates

Programming filter and volume envelopes from scratch can be complicated, so the DJ-70 software includes several factory Templates to help get you started. These Templates give you complete TVF and TVA setups, which you can then tweak to suit your needs. You also have the ability to create your own Templates, from Partials whose TVF and TVA parameters you might find yourself using often.

The Templates are accessed from the Com menu on any of the Edit Partial pages. Select Template, and the Template window opens. To choose a factory Template (the ones under the word

“<Preset>”), confirm on its name. The window will close, and you will be back on the Edit Partial page you came from, with the Template’s TVA and TVF settings imposed on the current Partial. (Although you can select a Template from any of the pages, the only pages it will affect are TVF and TVA.)

You create a Template for the “<User Set>” by taking the TVF and TVA envelopes from the Current Partial and telling the DJ-70 to memorize them. After you open the Template window, select the arrow under the word “<Get>” which corresponds to the user slot you would like this Template to be in. You can use any of the 10 slots you like, but obviously if there is a Template already in that slot, it will be replaced. The name of the Template will be the same as the Current Partial.

To use one of the Templates in the User Set, simply click on its name. If you click on an “empty” slot, the Current Partial will be unchanged. If you change your mind and don’t want to use any template, click on Exit.

You can’t edit a User Set Template, but you can replace it by the same procedure: load and/or select the Partial whose envelopes you want to use, and enter it using the <Get> arrow. Changing the parameters of the Current Partial after you’ve created a Template, or deleting it from memory or even from disk, will not affect the Template.

The Templates stored in the User Set are made permanent with the “Save System” operation, like the Jump pages. If you don’t do this before the end of your session, the Templates will be lost (or revert to their former state) when you turn off the power. Save System is available from the Index.

The factory Templates, and what they do, are as follows. Except for the last two, the TVF is disabled (Filter Mode set to Off), but the TVF page is given an envelope identical to the TVA page.

- Organ. Immediate Attack, maximum Sustain level, and immediate Release.
- Piano. Immediate Attack, moderately fast Decay, moderately slow Sustain to 0, but fast Release for “damping” on Note-Off.
- Brass/Wind. A smooth envelope. Slow Attack and Decay, with Decay Level higher than Attack Level. Moderately fast Sustain to fairly high level, followed by moderately fast Release.
- Compress. Simulates the action of a fast limiter, and adds “punch” to a sound. Immediate Attack and Decay at highest level, then very fast Sustain to a moderately low level. Fast release.
- Percussion Long. Immediate Attack and Decay at highest level, then slow Sustain to 0. Release same as Sustain.
- Percussion Short. Same as above, but Sustain and Release faster.
- Velocity String. Relatively slow Attack and Release, immediate Decay and Sustain at highest level. Near-maximum velocity sensing enabled, using Curve 2.
- Velocity Perc. Faster Attack and slower Release than above, Sustain level 0, Sustain time equal to Release time. Maximum velocity sensing enabled, using Curve 2.
- TVF Sweep Up/Dwn. For those spacey “analog” sounds. TVF has moderately slow Attack from 0 to full level, followed immediately by moderately slow Sustain back down to 0. Release is slightly faster than Sustain. Filter is Low-Pass, with medium Cutoff Frequency and Resonance. TVA has immediate Attack to full level, full Sustain level. Release the same as TVF.

- TVF Sweep Down. For “analog” sounds, and also useful for damping a bright loop over time. TVF has immediate Attack from 0 to full level, followed immediately by moderately slow Sustain down to 0. Release is slightly faster than Sustain. Filter is the same as above, and TVA is the same as above.

Remember there is no “Recover” or “Undo” function available, so if you have created a Partial you really like, save it on disk before sticking a Template on it. Once you’ve done that, try the factory Templates on all sorts of sounds, and see what you come up with. Even short Samples with no Sustain loops (discussed in the next chapter) can have interesting things done to them with the Templates.

LFO

One more thing you can do to a Partial is apply vibrato of various kinds using a Low-Frequency Oscillator. This is done on the Edit Partial LFO page. Vibrato can be applied to a Partial’s pitch, to its TVF, and/or to its TVA.

Parameters

The LFO parameters are set at the top of the screen:

Wave Form lets you select among several waves for the LFO: Sin(e), Tri(angular), Saw(tooth) Up, Saw(tooth) D(own), Square, Random, B(e)nd Up (a non-repeating bend which starts below the note and slides up to it), and B(e)nd D(own) (which starts above the note and slides down to it).

Rate controls the basic speed of the LFO. It can be set from 0 (which is not Off, but is very slow) to 127.

Detune is a randomizer for the Rate parameter. It will change the LFO rate somewhat with each new Note-On, so that each note as it plays has a slightly different vibrato speed. (Allow the author a personal observation here: this is an incredibly neat feature for doing realistic orchestral simulations.) The value of the parameter (from 0 to 127) determines the overall spread of the randomization: at low values, the vibrato speed differences between subsequent notes will be very subtle, almost like a phasing effect. At the highest values, the difference in vibrato speed from one note to another will vary as much as 100%, that is, one note may have vibrato twice as fast as another.

To hear this in effect, select Vox F#4 low and crank the Detune parameter up to 127. Bring Rate up to 65, and then move down to TVF Mod Depth and set it to about 39 (yes, we know we’re getting ahead of ourselves here). Play a chord and hold it. You’ll hear a wah-wah vibrato effect that goes at a different speed for each note.

Delay sets a period of time after a note starts before the LFO begins to affect it. At 0 there is no delay, and the vibrato starts immediately. At the maximum value, 127, the delay is about 25 seconds.

Key Follow determines whether the MIDI Note-On number will have an effect on the Delay. At 0, all MIDI notes will have the same delay. As the value is increased (the maximum is 63), higher MIDI notes will have progressively shorter delays.

Key Sync determines whether the vibrato waveform will start in the same place for every Note-On. If it is On, then the vibrato for every note will begin at the same point in the LFO waveform. If it is Off, the starting point of the vibrato waveform for each note will be different.

A chord gives us a good illustration of how this works. Set Rate to 48, Detune to 0, and Pitch Mod Depth (there we go again!) to 45. If this parameter is On, then all the notes in the chord will move in parallel. If it is Off, the vibrato for each note in the chord will start in a different place, and will move against each other in various phase combinations.

The LFO Assignments

What the LFO actually does to the sound is determined at the bottom of the screen. The LFO can be applied, in any combination, to:

- the Partial's pitch (Pitch Mod Depth);
- the TVF, periodically raising or lowering the filter Cutoff Frequency as the TVF envelope progresses (TVF Mod Depth); or
- the TVA, periodically raising and lowering the volume as the TVA envelope progresses (TVA Mod Depth).

If the LFO waveform is Bend Up or Bend Down, then the effect of the LFO on the pitch, TVA, or TVF is not periodic, but is a single occurrence.

The Depth parameters have a range of -63 to +63. Negative values apply the waveform with its phase reversed.

Editing Partials through the Patch page

As mentioned in Chapter 3, the Edit Partial pages behave slightly differently when you enter them through a Patch page's Com menu (in Subsidiary mode), instead of the Sound menu or the Index. There are four main points to be aware of.

To illustrate, let's load in a complex Patch. From the Disk Load page, select Patch as the Target, and load. When the file is loaded, go to a Patch page, not a Partial page, open the Com menu and select Edit Partial. When the Edit Partial page opens (whichever one it is), its name will appear with "stars" around it, indicating that you are in this special mode.

1) Restricted access to Partials

First of all, the Partials you will be able to select for editing will be limited to only those Partials that are subsidiary files of the Patch that you came from, even if there are other Partials already in RAM. If you scroll the Current Partial line at the top of the page, you will only be able to scroll to those Partials that are in the current Patch. If you put the cursor on the Select box and confirm

pressing S1 or S2 buttons, the names of the Partials you can access will appear in the Select window.

You can load a new Sample from disk and put it into one of the Patch's Partials, and you can even load a new Partial from disk, and put the Samples it contains into one of the Patch's Partials. But you cannot access the newly loaded Partial itself, because that Partial is not a subsidiary of the Patch.

This restriction, however, does not apply if you are working with a brand-new Patch, to which no Partials have been assigned. In that case, all Partials are accessible.

2) Automatic Partial Switching

The second difference is that if the Patch contains a Split, the Split will remain active while you are on the Partial page. As you play notes on your MIDI keyboard, you will hear the different Partials, and the display will also change to show which Partial is sounding. (The Partial will actually change only if it is assigned to a MIDI note at the Split level - this Patch uses only notes between F#3 and D#5, and not all of them.)

This makes it easy to keep track of which Partials are assigned to which notes, and how they sound in the proper context. However, it also means you have to be careful not to hit a wrong MIDI key while editing, or you may end up editing the wrong Partial.

3) Not Omni Mode

The DJ-70 will no longer necessarily respond to incoming MIDI data on all channels. Instead, it will respond only to MIDI signals on the channel selected in the Patch page that you came from. If the Select/MIDI in parameter is set to Omni On, that will be all channels. If it is set to an individual Part, then the unit will only respond on the MIDI channel corresponding to that Part.

In addition, if you are editing a Partial from a Performance, any range restrictions or fades imposed on the Part by that Performance will be in effect (see Chapter 8).

4) Global Editing

Finally, when editing a Partial from within a Patch, you may choose to have the changes that you make affect all of the Partials in the Patch simultaneously. This is done by selecting the word "Single" on the Partial line and pressing the S2 button once. It will change to "Global". Now any changes that you make in any Parameter on any of the Partial pages will change that particular Parameter for all of the Partials in the patch at the same time. This includes Samples - if you change the Sample in any one of the four slots in a Partial, all of the Partials in the Patch will now have that Sample occupying that slot. This switch is inactive if the current Patch has only one Partial assigned to it.

While this feature is not of great value in mapped Patches like this one, it can be a convenience when dealing with multisampled Patches. Global editing of envelopes, for example, makes it much faster to get consistent response over the entire keyboard range for a Patch that uses several Samples.

If you want a parameter change to affect only one Partial, press the S1 button to change Global back to Single, and now any changes will only affect the Current Partial.

The Partial Map

Another way to edit Partials from within a Patch is to use a special set of pages called the Partial Map, which are accessible only through one of the Patch pages. We'll discuss the Partial Map momentarily.

Other Partial Functions (the Com menu)

Several other functions that affect Partials are available through the Com menu on any of the Partial Edit pages.

Disk

The Disk function (Load A, Load B, Load A/B, Util) is the same as in other modes and is described in Chapters 3 and 9. When you Load a Partial, it loads in all subsidiary Samples, unless you set the Target to Partial PRM, in which case only the Partial's Parameters are loaded. This way an existing Partial can easily be used as a template to organize a different set of Samples.

When you Save a Partial, any new Samples you have created get saved with it. In addition, any old Samples that are subsidiary to the Partial will be saved. If you Delete a Partial from disk, all subsidiary Samples are deleted as well.

Delete

As with Patches, the Delete function on the Com menu lets you select a Partial to remove from RAM. The Delete function only works on RAM - the files on disk are not changed unless you go through the Disk function.

As you pass the cursor over the names of the Partials in the Delete window, you can hear each one if you play the MIDI keyboard. This can help you determine which Partial you want to lose. If you are editing Partials through a Patch.

Files at the bottom of the list (higher numbers) will delete faster than those at the top.

Down and Down: Moving to the Sample Level

The last three commands let you move down to the Sample Edit level and work with one or more Samples, similar to the way you can move to the Partials function directly from a Patch page. One major difference, however, is that your access to Samples in RAM is not restricted to those Samples that are subsidiary to the Partial you're coming from - the Sample pages always behave the same way no matter how you get to them. More on this in the next chapter. When you Exit the Sample level, you will come back up to the Partial Edit level.

Edit Sample1 moves you to the first set of sample pages, and Edit Sample2 moves you to the second, advanced set. Sampling moves you directly to the Sampling page (the first page of the Edit Sample1 level). When you go to the Sampling page from a Partial page, what happens is similar to what happens when you go from a Patch page: the page is labelled Sampling from partial, and when you record a Sample, the software automatically creates a new Partial with the same name that you've given the Sample. This happens whether you select Sampling from the Com menu, or you select Edit Sample1 from the Com menu and then move to the Sampling page.

When you exit any Sampling page, you will go back to the Partial page you came from.

The Partial Map

The Partial Map provides you with an alternative view - from another dimension, some might say - of the parameters for the Partials in a Patch. Instead of showing you groups of parameters on an individual Partial basis, Partial Map lets you look at only one parameter at a time, but you can see how that parameter is set in many Partials simultaneously.

The Partial Map can be accessed only from a Patch page, by opening the Com menu and selecting Partial Map.

There are three Partial Map pages, and they differ only in the pitch range that they show you. The first page, A Ø~, shows the notes from AØ (MIDI note number 21 decimal) to C4, a total of three octaves plus four semitones. The other two pages show you a four-octave range starting from either C#2 or C#4.

Select the patch you want to look at just as if you were in a Patch page, and select the appropriate Part number and MIDI channel to receive on. (Notice that, unlike the Edit Partial pages, you can change the name of the Patch on these pages, but not the name of a Partial.) On the line labelled Parameter, use the S1 and S2 buttons to scroll among all of the parameters found on the Partial Common, TVF, TVA, and LFO page (except the parameters on the Common page that deal with individual Samples): they include all of the envelopes and other TVF and TVA settings, and end with LFO TVA Mod Depth from the LFO page.

When you select a parameter, the display shows the current setting of that parameter for each note on the screen.

Move the cursor over the parameter value next to the note, and use the S1 and S2 buttons (or VALUE wheel) to raise or lower the parameter. The values for all other notes that are assigned to the same Partial will change at the same time. Also, the name of the Partial whose values you are adjusting will appear at the bottom of the screen under the word Partial.

If you're not sure which note names correspond to which keyboard keys, at any time you can play one or more notes on your keyboard, and an arrow will appear next to each note you play.

When you are done with a Partial Map, you must go back to the Patch page you came from by clicking Exit. (The Partial Map pages have no Com menu.) You can then go to the other Partial Edit pages if you like. Any changes made on the Partial Map page will of course be visible on the other Partial Edit pages as well.

Chapter 6: Sampling 1 - Recording and Looping

Up to now, we've been working with Samples already recorded on the disk supplied with the DJ-70. Of course, besides the sample-manipulation features we've been exploring, the DJ-70 has extensive sample recording and editing facilities. In this chapter we will discuss how to record samples and automatically loop, truncate, create the relative partial and patch and assign it to one of the white keys of the keyboard. Looping is usually a non-destructive technique that preserves all of the original sample data. In the next chapter we will discuss more sophisticated editing functions, which change the sample data.

Samples are recorded and edited using the two Edit Sample functions. The Sample1 functions fit onto five Pages. Each page has its own Function keys, pressing and holding the the Shift button from each of these pages you can choose from one page to another. They can also be reached by a wide variety of ways, and each route has its own specific destination:

- Select Sample pressing the F5 System Key from the Play Page 1 and you will go to the Sample1 page you were on the last time you were at this level. If this is the first time you are entering this function, you will go to the Sampling page.
- Select Edit Sample1 from the Sound menu, and you will go to the Sample1 page you were on the last time you were at this level. If this is the first time you are entering this function, you will go to the Sampling page.
- From a Patch page, open the Com menu and select Sampling, and you will go to the Sampling page.
- From any of the Partial pages, open the Com menu and select Sampling, and you will go to the Sampling page. Select Edit Sample1, and you will go to the Loop1 page.

Note: When you record a Sample, it automatically creates a Partial and a Patch with the same name as the Sample. The name is automatically assigned using the item name and a progressive number. (Sample + num) - (Partial + num) - (Patch + num). The patch created is automatically assigned to the first free white key.

When you Exit a Sample1 page, you will go back to either the Sound menu, if you came from there or the Index, or else the Patch or Partial page you came from.

The Sample2 functions have their own menu, which contains two items. Each of these items, in turn, has one, two, or three pages. To get to the Edit Sample2 menu, there are again several paths:

- Select Edit Sample2 from the Sound menu.
- From any of the Partial pages, open the Com menu and select Edit Sample2.
- Use a Jump page to go to a Sample2 page that you have programmed.
- From the Index, under the Sound category, a number of Topics and Subtopics will lead you to Sample2 pages. See Appendix E for a complete list.

When you leave a Sample2 page, you will always go to the Sample2 Menu.

Recording a Sample

The first page of the Sample1 function, Sampling, is used for recording Samples. Before you record a Sample, you must select a slot for the Sample, and set the Parameters on this page according to how you want to record. The default values are set to satisfy most of the common uses. After that is done, start the sample recording process by pressing Ready function key (F1).

To keep this simple, let's look at recording a Sample. To take the most direct path to the Sampling page, press the F5 function key from the Play Page 1 and go to the Sampling page.

Setting the Parameters

Selecting the Slot and Naming

The first thing to do is decide where you want to put the Sample. The DJ-70 automatically selects the first free slot. Select a slot by scrolling in the Current Sample line at the top of the screen, or using the Select icon. If you already have sounds in RAM, one or more Sample slots will already be occupied. If you select one of those slots to record in, the Sample already in it will be erased. If you don't want this to happen, select a blank slot,

either by scrolling with the S1 or S2 button until a slot appears that has no name, only a slot number, or by opening the Select window and choosing Blank.

The DJ-70 will let you record a Sample with the name Sample 1.

Sample		ComExt	
<input type="checkbox"/> Sample	1: - empty -		
Mode	Mono	Type	1-way
Orig Key	F 4	Trig	Start/End
Freq (kHz)	44.1	Time (sec)	4.5
Threshold	—	Pre-Trig	—
Monitor	On	Normalize	Off
Remaining	18.0		
<div style="border: 1px solid black; padding: 5px; margin: 10px auto; width: 80%;"> LEVEL <input type="checkbox"/> </div>			
Ready /		Name /	

It automatically also creates a partial called Partial 1 and a patch called Patch 1. After these operations it assigns Patch 1 to the first free white key of the keyboard.

Mode: Mono or Stereo

The next decision you must make is whether you want to sample a mono source or a stereo one. The default choice is Mono, but of course you can easily change it. Stereo Samples, obviously, take up twice as much memory as mono ones. Stereo Samples are actually two mono Samples that are manipulated together. They can be easily split into individual mono Samples, and in some cases recombined - see "Working with Stereo Samples" later in this chapter.

Original Key

This will determine the "base" note for your sample. It defaults to F₄, which is normally Middle F (MIDI note 60 decimal). If you are sampling a sound whose actual pitch is F₄, you would normally assign its original key to F₄ so that when you play it back, it is in tune with other samples and other instruments.

This is especially important when you are Multisampling, that is, using several Samples of an instrument taken at different pitches to cover a wide range of notes without "munchkinization" (see the section on Splits in Chapter 4). By setting the Orig Key of each Sample to the pitch of the actual sound, it will be much easier to keep track of the Samples, and you will need to make fewer adjustments when you assemble them in a Patch.

If you are recording a sound that you want to map later to a specific keyboard key, like an individual drum or a sound effect, you can assign that key here. This setting can be overridden at the Partial level (and if you turn off Key Follow on the Partial, this Parameter is essentially irrelevant), but you can avoid some possible confusion by setting it up correctly here. It can also be reset on some of the sample editing pages, if you need to adjust it after it's been recorded.

Freq

This selects the sampling frequency, which when you first turn on the DJ-70 will be settable to either 44.1 kHz or 22.05 kHz. The higher frequency gives the best quality. The lower frequency will still give good quality on sounds without too much treble content, and will allow you to store twice as much sound in RAM or on disk.

A Sample's rate can also be changed after the fact with the Rate Convert feature.

Samples that are loaded from an S-550/S-330/W-30 disk will have a sampling rate of 30 kHz. Even though you can't get the DJ-70 to sample at 30 kHz, these Samples can be treated like any others. We mention this so you don't get confused when you encounter one of these.

Time

This reserves a specified amount of RAM for your sample. It can be set anywhere from 0.1 second (0.2 second at the slower sampling rates), up to the maximum time currently available in RAM. It Default to 4.5 seconds that are enough for 2 bars of music at 120 BPM. Set it so you have a comforta-

ble margin of error - if you know a sound is 2 seconds long, give it 2.5 seconds of RAM. You will not waste any memory by setting this too high, because the DJ-70 automatically truncates the sample in the point where you press the START/END Button. You can always truncate the sample afterwards (see the next chapter), and whatever memory you cut is then put back into the available RAM.

In Chapter 3, we mentioned that time-length Parameters in the DJ-70 are usually displayed referenced to a 44.1 kHz sampling rate, so that accurate and consistent comparisons can be made between sizes of files. The Time Parameter and the Remaining parameter at the bottom of the column, however, don't follow this rule.

On this Page only, the times are shown referenced to the current (that is, full-speed or half-speed) sampling rate. This is to allow you to set up a specific amount of memory for the Sample you are recording without going through a lot of mental calculations in case you're using a sampling rate other than 44.1 kHz. Once you leave the Sampling page after the Sample is recorded, any Remaining Parameter you see will be referenced to 44.1 kHz. (The Resampling function, discussed in the next chapter, also has this Parameter referenced to the current sampling rate, but let's not get ahead of ourselves.)

If the Remaining parameter is $\emptyset.\emptyset$, you will not be able to record a Sample. You will also see a message in the middle of the LCD "Wave Memory full". If this is the case, you will have to remove one or more Patches and relative partial and samples from RAM. Use the Delete function from the Com menu - see later in this chapter for details.

One more thing about the Remaining parameter: if the line at the top of the Lcd Display is showing a Sample (as opposed to an empty slot), the software assumes that you want to record over this Sample, and so adds its length to the available memory. Therefore, the parameter will change as you change the current Sample.

Triggering

You have several choices of how to get the sample recording process started. These choices are selected by the Type, Trigger, and Threshold parameters. Remember that the sample recording process won't actually start until you press the "Ready" function key, so feel free to experiment with the different Parameters.

Automatic Triggering

When Auto is selected for Type, the DJ-70 will start recording when it receives a particular signal. The type of signal it's looking for is determined by the Trigger parameter.

If Level is selected for Trigger, then the DJ-70 will start recording when an audio signal exceeding the Threshold level is received. The Threshold is adjustable in units from 0 (recording will start immediately even if no signal is present) to 127 (a very high level is necessary). As the Threshold is adjusted, an arrow appears in the Graphic "Level" window on the screen, showing the position of the Threshold setting, relative to the level of the incoming signal. Any input signal that shows up to the right of the arrow will start the recording, while if the signal stays to the left of the

arrow, the recording will not start. Once recording starts, it keeps going until the time allotted in the Time parameter is used up, even if the signal drops below the Threshold level.

Selecting MIDI means recording will start when a MIDI note-on (but not a controller or program change) command is received by the DJ-70. The DJ-70 is in MIDI Omni mode when the Sample pages are showing, so any MIDI channel will work for a trigger.

Manual Triggering

Setting Type to Manual means that the DJ-70 will start recording only when the Start/End button on the panel.

Setting Type to Prev(ious) means that the sampler is always “listening” to the incoming audio signal and storing it in a circular buffer, which is constantly being cleared and refilled. The size of the circular buffer is determined by the Time parameter. The moment you click on Start/End sample on the panel, the buffer is frozen and stored in RAM. This means that, if Time is set to 2.5 seconds, then when you click on Start, the 2.5 seconds of audio previous to your pressing Start/End is recorded.

Previous Sampling provides an excellent way for grabbing sounds off of a recording, either an individual sound or an entire phrase, because you don't have to anticipate when the sound you want will occur - you can tell the sampler to capture it right after it happens.

1-Way is the default mode. It is a special quick sampling mode that processes the sample faster than other modes, so that you don't have to wait after recording to hear it. It can be triggered from Start/End button, level, MIDI. You can use it when you are recording a series of similar samples, one right after another. However, you cannot set up a Pre-trigger buffer (coming up) with this mode.

Other Parameters

Pre-trig sets up a buffer that will hold a small amount of sound prior to the actual recording. It is used with level-threshold triggering to make sure that the transient at the very beginning of a sound does not get cut off when the level threshold opens. It is calibrated in 1/100ths of a second. You can be generous with this Parameter - if you end up with extra space at the beginning of the Sample after it is recorded, cutting it off is easy (see Truncate in the next chapter).

Normalize automatically normalizes the sample - that is, brings its overall volume up to the highest level possible without distortion - right after it is recorded. You can also normalize a sample after the fact, using the Normalize page (see next chapter).

Monitor, when switched On, means that the input signal to the DJ-70 appears at the Stereo audio outputs. Turn this on when sampling electronic sources, and turn it off when sampling with microphones, to prevent feedback.

Doing the deed

Enough preparation already! When the Parameters are all set the way you want, press the Ready function key. There will be a brief pause while the DJ-70 allocates the amount of RAM you specified for the sample (if you reserved a lot of RAM, this pause may be a few seconds long).

Now the Sampling execute window appears. The Type, Trigger, Threshold, Monitor, and Length settings are displayed at the top of the screen, and you can change them (except Length) if you like. The “level meter” box is at the bottom. There will also be some indication of what kind of triggering you’re using in the box: a threshold arrow, the word “MIDI”, or the word “pedal”.

To “arm” the sampler - that is, have it start listening for its trigger, or if the Type is 1Way, have it start to record - press the Start/End Sample button. If you chicken out, press EXIT, and you will go back to the Sampling page.

As you are recording, the vertical “thermometer” next to the Level window will fill up, as the memory you have reserved (in the Time parameter) fills up.

When the thermometer reaches the top, there is a pause. (This pause can be fairly long if the Sample is long; using the 1-Way mode will eliminate the pause.). You can now play the Sample from your keyboard or MIDI (the DJ-70 will be in Omni mode) to see how it sounds, and decide what you want to do with it.

If something goes wrong during the recording, or if the sound ends before memory is filled up, you can cut off the recording any time after you have pressed Start/End Sample by pressing either Start/End button again or pressing the EXIT button. This takes you back to the Sampling window.

Listening to the Results

Play the Keyboard or the MIDI key named in the Orig Key parameter to hear the Sample just as it was recorded. Play up and down the keyboard to hear how it sounds transposed. You can go up two octaves (three if you’re sampling at half speed), or down any distance. You can play notes above the top of that range, but the sound won’t go any higher.

If you are sampling an instrument that you want to use over a wide keyboard range, this is a good time to determine how far you can transpose it in either direction before it starts to sound strange, so you can get an idea of how many more Samples you will need to take to create a good Multisample, and at what intervals.

Recording Samples from a Performance

You can also record a Sample from a Performance Play Page. Opening the Com menu and selecting Resample2 opens a special version of the Sampling Page, called Performance Resampling. This Page works the same way as Sampling, but is simpler: recording can only be triggered by a MIDI note-on (on any channel), and monitoring is not available. Automatic normalization, however, is available.

The Input Parameter, which is normally set to Analog, has two new choices: Internal L and Int R. These are used for resampling complex multi-channel sounds, and will be discussed in the section on resampling in the next chapter.

When you record a Sample on this Page, a Partial and Patch with the same name are created as well. Back on the Performance Play page, you can immediately play this new Patch into a slot in the next available Performance.

Other Sampling Functions

Before we go on to editing, we need to look at several other functions that affect Samples, which are available through the Com menu on any of the Sample Edit1 or 2 pages.

The Disk functions are the same as in other modes and are described in Chapters 3 and 9.

As with Partials and Patches, the Delete function removes the currently selected Sample from RAM. It is useful when you need to free up RAM for recording, editing, or loading more Samples. The Delete function only works on RAM - the files on disk are not changed. You can hear each Sample in the Delete window by passing the cursor over it (but not pressing the S1 or S2 buttons). Files at the bottom of the list (higher numbers) will delete faster than those at the top, so if you're deleting a lot of files at a time, it's best to start at the bottom and work your way up.

Copy, as in the other modes, lets you make a duplicate of the Current Sample and place it elsewhere in RAM. Select the Current Sample in any Edit page, then open up the Com menu and click Copy. In the window that opens, choose an empty slot to place the copy. The new version has an "-N" suffix attached to its name. If the Sample is stereo, both halves will be automatically copied into two slots (even if the Edit Mode on the page is set to Mono), and one half will appear with "-NL" and the other with "-NR".

Copying a Sample uses up RAM, unlike copying a Partial or a Patch. If Internal Memory is close to full and you try to copy a Sample that won't fit the remaining RAM, you will get a "Can't Execute" error message.

Working with Stereo Samples

A stereo Sample actually consists of two mono Samples, which have the same names, except that one ends in the suffix "-L" and the other in "-R". Once they are set up as a stereo Sample, they can be linked throughout the Sample-editing process. Each editing page has an Edit Mode parameter, and as long as it is set to Stereo, then anything you do on one side of the Sample - setting a loop, changing the name, truncating, or smoothing - will automatically apply to the other side as well. When you play a keyboard or a MIDI key to hear a stereo Sample when one side of it is showing on the Lcd, you will hear the other side as well. The sound comes out of the stereo outputs, with each Sample playing on the audio channel it was recorded on.

Note that this link only is in effect on the Sample editing pages, and when you use the "[*]" switches on the Partial pages to load the Sample into a Partial. Otherwise, when stereo Samples are put into a Partial, or more importantly, loaded from or saved to disk, they must be handled individually as two separate Samples.

Once you switch the Edit Mode on any Sample editing page to Mono, the links between the two Samples are temporarily broken, and they are treated as two mono Samples. However, you can re-establish the link any time by setting Edit Mode back to Stereo, as long as you haven't done any destructive editing or changed the name of either of the Samples. (If you have, you won't be able to change the Edit Mode parameter.)

Converting Mono Samples to Stereo

If you have edited one or both halves of a stereo sample, you can still re-combine the two mono Samples (or for that matter, any two mono Samples that are the same length) into a stereo Sample, using the “Set Stereo” function from the Com menu.

Open the Com menu and select Set Stereo. A window will open asking you which two Samples you wish to combine, Source 1 and Source 2. After you select them, you can assign a new name to the resulting stereo sample by selecting the Name box. The two halves will have this new name, plus the -L and -R suffixes. If you don't assign a new name, the new stereo pair will have the same name as the Source 1 sample, plus the suffixes. Select the Execute switch, and the two Samples will be re-named and linked.

When combining two Samples in this way, both Samples must be in RAM, and be of identical lengths. (But they don't have to have the same sampling rate or original key.) Therefore, if you have truncated one of the halves of the original stereo Sample, you must truncate the other half by exactly the same amount before you can re-combine them. Loop settings, however, can be maintained separately, so you could end up with two halves of a stereo Sample that have very different loops. We'll discuss the implications of this later in the chapter.

Converting Stereo Samples to Mono

You can also convert one side of a stereo Sample into a mono one. Open the Com menu, and select Set Mono. In the Source parameter line, select the Sample you want to convert. Again you will be asked for a name for the new Sample you're creating, and the default will be the name of the Source sample, without any channel suffix. If you have already converted one side of the Sample without changing the name.

Select and confirm on Execute and the operation is done. The old version is gone, and the new version has no channel suffix and no link to another Sample. Incidentally, you can perform essentially the same task by changing the Edit Mode on the Sample to Mono, and then saving it under a new name.

You can mix the two sides of a stereo Sample into a single mono one using the Resampling function, described in the next chapter.

Editing Samples

Remember that when editing Samples, one Sample may be used in two or more different Partials, Patches, or Performances, and if you alter it, you alter it for all of its uses. If you are working on a Sample that you are using in a particular context and don't want to change it in its other contexts, give it a new name and save it to disk.

Playing Samples while editing

The Edit Sample pages always respond to MIDI in Omni mode, so no matter what channel your MIDI keyboard is transmitting on, the DJ_70 will respond. The MIDI controller functions

(LFO response, pitchbend range, etc.) are determined by the settings made on the Edit Patch Ctrl page of the last Patch to be loaded or edited, or if there has been no Patch loaded or edited since boot-up, the default settings will be used.

You can also listen to a Sample (or any other file) by using the built-in 37 keys keyboard.

Looping

Often when a sampled sound is being used, all that's needed is for it to play through directly from the beginning to the end - which is known as "one-shot" playback. But there are many musical circumstances in which it is desirable to sustain a sampled sound for a longer period of time than simple one-shot playback will allow.

For example, if you wanted to play a one bar Drum riff and hold it for twenty seconds, you would need a twenty-second drum Riff Sample. You would therefore need to have available Samples that are long enough to accommodate the longest possible duration anyone would ever want, and this would create impossible demands on memory and storage.

To avoid this, a section or all the Sample, can be "looped". Now when a key is struck and held, the Sample plays from the beginning and through the looped area, and then when it reaches the end of the loop, it starts again at the beginning of the loop. The loop repeats as long as the key is held down. The sound can change while the loop is playing, if the Partial containing the Sample has a TVA, TVF, or LFO that makes it change, but the loop itself (known as the Sustain loop) repeats unaltered until the key is released.

At or after that point, often a second loop, known as the Release loop, may start, and it plays or repeats until the volume envelope (TVA) fades it out.

Loop editing in the DJ-70 is a non-destructive process - the entire Sample being looped is always maintained intact in RAM and on disk, regardless of the loop settings. However, since the loop points are saved on disk as part of the Sample, if you make major changes in a loop and also want to keep your original version, you should copy the Sample to a new slot before working on it.

Edit Sample Loop		ComExt	
<input type="checkbox"/> Sample	1: Sample	1	
Loop Mode	Forward	Start	0
Edit Mode	Mono	Loop	0
KeyOn Mode	Start	Fine	0
Length Lock	Off	End	60877
Disp Type	Loop	Tuning	0
Edit Step	100	R-Loop	73720
X-Zoom	x1	Fine	0
Y-Zoom	x1	End	73724
		Tuning	0
Remaining	17.8		
44.1K 1.6/ 73728			
Start	End	Loop	Name / x100

The Sustain and Release loops are set up on the Edit Sample Loop page. Let's look at this page.

The top line of the page lets you select which Sample to work on, either by scrolling the parameter or using the Select icon. You can also rename the Sample.

Loop Mode

Loop Mode is a very important Parameter. It determines how the Sample and its loop(s) are going to be played, both while you are on this page and when the Sample gets “kicked upstairs” into a Partial.

- Forward means the Sample will play from the beginning, go through the Sustain loop and repeat while the key is held down. At the Partial level, when the key is released, it will fade out, still repeating, according to the Partial TVA’s release time. The TVA is not in effect, however, when you are working on this and the other Edit Sample pages, so you won’t hear this fade unless you go up to the Partial level. Here, the sound will simply stop when you release the key.
- Fwd+R is the same, except that when the key is released, it finishes the current iteration of the Sustain loop, and then plays the next part of the Sample after the Sustain loop. When the Release loop is reached, it starts to play, and it repeats for as long as the Partial TVA’s release time lets it. Again, since the TVA is not in effect, you won’t be able to hear this. You will be able to hear the Release loop, however, if you change the KeyOn Mode, which we’ll discuss in a moment.
- OneShot plays through the sample once, from the very beginning to the end of the Sustain loop, without repeating.
- Fwd+One plays from the beginning, repeats the Sustain loop until the key is released, finishes the loop, and then plays the rest of the sample and the Release loop one time only (if the TVA release time allows).
- Alt plays from the beginning and repeats the Sustain loop, with each alternate iteration of the loop being backwards - so that the loop plays alternatively forward, backward, forward, backward, etc. - until the key is released. This gives the effect of a loop that’s twice as long.
- Rev One plays the sample once, backwards, from the end of the Sustain loop to the very beginning.
- Rev sets up a new loop, which extends backwards from the beginning of the Sustain loop point to the beginning of the sample. It then plays the sample backwards, starting from the end of the original Sustain loop, and when it reaches the beginning of the loop, it repeats the new loop, also backwards, until the key is released.

KeyOn Mode

KeyOn Mode determines what happens when you strike a MIDI key while you are working on the Sample. (Remember that the DJ-70 is in MIDI Omni mode when editing Samples.) It is only applicable to the Edit Sample pages, and has no effect on what happens to the Sample when it is used in a Partial.

- Start means that the Sample will start playing from the beginning, and play through the end of the Sustain loop. The Release loop will not sound.

- Loop means it will start playing from the beginning of the Sustain loop and play through the loop's end. The Release loop will not sound.
- R-Loop means it will start playing from the beginning of the Release loop and play through the end of the Release loop. This is the only way to hear the Release loop while you are on any of the Edit Sample pages.
- R-End lets you hear what remains of the sample after the end of the Release loop - in other words, what is being left out at the end.

Other Parameters

Edit Mode, as explained earlier, determines whether you will edit both sides of a stereo Sample simultaneously (Stereo) or one channel at a time (Mono). If the Sample is mono, this Parameter will always be Mono. We'll talk more about looping stereo samples at the end of this section.

Length Lock we'll get to in a minute. Leave it Off for now.

Display Type is discussed below under "Using the Waveform display". Most of the time you will want this to be set to "Loop".

Edit Step lets you set how much the Start, Loop, R-Loop, and End Parameters in the right-hand column will change when you select them and press the S1 and S2 buttons or move the VALUE wheel. It is adjustable in powers of 10, from 1 to 10000. High values are used for coarse adjustments, and low values for fine adjustments.

X-Zoom and Y-Zoom control the magnification of the graphic Waveform display at the bottom of the Lcd. X-Zoom controls the horizontal magnification, and Y-Zoom the vertical. Set to their lowest value (x1), these controls let you see an entire Sample. Increasing the value of X-Zoom makes it easier to edit loop points, which we'll discuss in detail in the section on the Waveform display. Increasing the value of Y-Zoom can help in the editing process when the signal level at a loop point is low. (If you set the Y value too high, the sample will appear to "clip" at the top and bottom of the display, but actually the sound is not affected.)

Both Parameters can be set to x1, x4, x16, x64, and Max. (If the sample is short, X-Zoom settings of x64 and Max will give the same display.) When X-Zoom is x1 the Y-Zoom setting has no effect.

The Loop Point Parameters

Start

Start, at the top of the right-hand column of Parameters, sets the beginning point for the Sample playback, both on this page and when the Sample is placed in a Partial. While normally we deal with Samples in terms of their length in seconds, here we have to get more precise, and deal in bytes. The number of bytes in a Sample is equal to its length in seconds multiplied by its sampling rate. The Start parameter tells you on which byte the Sample will start playing at, which can be anywhere from 0, the very first byte, to very nearly the last byte in the Sample.

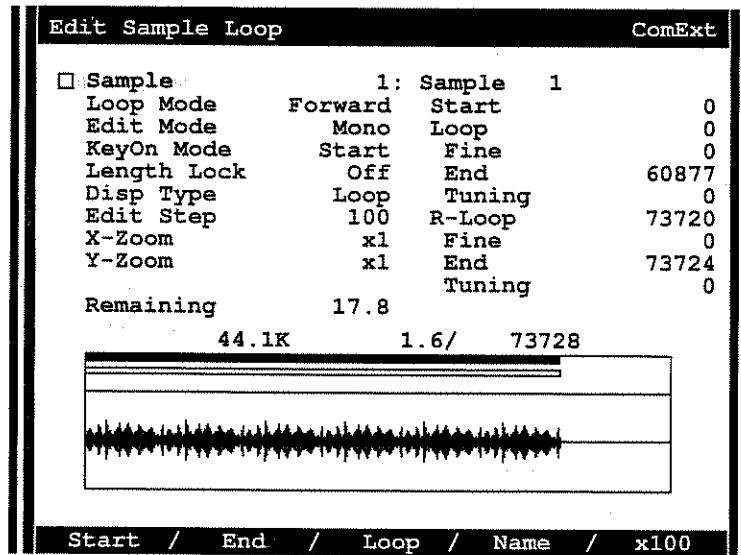

The Start parameter can be critical if you are transposing a Sample downwards any great distance. If there is any delay at the beginning of the Sample, as you transpose it down the delay will be multiplied, and can seriously affect the sound's keyboard response. Butting the Start point right up against the beginning of the actual sound can minimize this. The Start point can also be in the middle of a loop, so you can play a Sample from the middle, and then have it jump back and start looping at an earlier point. However, the Start point cannot be located past the end of the Sustain loop.

Remember that looping is non-destructive, so that bytes before the Start point are still there as part of the Sample, you're just not hearing them. If you want to permanently eliminate bytes at the beginning of a Sample, use the Truncate function, described in the next chapter.

Sustain Loop

Loop determines the starting point of the Sustain loop. It can be set to be equal to Start, so that the loop starts immediately, and it can be set to a lower number, so the Sample starts playing in the middle of the loop.

Fine adjusts the location of the Loop point by interpolating between the individual bytes. Its effect is quite subtle, and will mostly be noticed on loops of very short duration.

End determines the ending point of the Sustain loop. It must be higher than Loop or Start (whichever is higher) by at least 4 bytes.

Tuning changes the pitch of the Sustain loop relative to the rest of the Sample. It is useful

when a Sample makes a slight rise or dip in pitch as it progresses, and you don't want that pitch change to be sustained, so you nudge it up or down. It is also useful with a very short loop which may not be in tune with the rest of the Sample.

Being able to adjust the tuning can be useful even when you're not looping at all (in OneShot or RevOne mode), but just want one section of the Sample to be at a different pitch than the rest of it. The range is ± 50 cents, equal to 1/4-tone up or down.

Release Loop

R-Loop determines the starting point of the Release loop. It must be at least 10 bytes after the End of the Sustain loop.

Fine subtly adjusts the R-Loop point.

End determines the ending point of the Release loop, which must be at least 4 bytes after R-Loop.

Tuning adjusts the pitch of the Release loop relative to the rest of the sample.

Restrictions and Relationships of the Loop Points

If you find yourself in a situation in which you cannot adjust a Parameter to the value you want, it may be because another Parameter is preventing it from changing. For example, if the Sustain loop End is at 27890, and the R-Loop starts at 27900, you won't be able to set Sustain loop End to a higher value unless you first increase the value of R-Loop higher to get it out of the way.

If you have set up a loop which is the perfect length, and you want to move it to a different point in the sample without losing its length (or being forced to recalculate it), you can turn on the Length Lock parameter (I promised we'd get to it!) on the left side of the screen. When this is on, if you change the Loop or R-Loop parameter, the corresponding End parameter will automatically change by the same value, and vice versa.

Timed Loops

The Loop Parameters allow you to design loops that are a specific length of time with a great degree of accuracy. If you have, for example, a Sample recorded at 44.1 kHz, then a loop that is 44,100 bytes long will be exactly one second long. If you know the tempo of a song, and you want to create a Loop that fits a precise number of beats, here is a formula you can use to calculate the loop length:

$$\begin{aligned} \text{Length of Loop (in bytes)} &= \text{number of beats} \\ &\times 60,000 \\ &\times \text{sampling rate (in kHz)} \\ &\div \text{tempo (in beats per minute)} \end{aligned}$$

If you design a Loop of a particular length and want to adjust it for smoothness, turn on the Length Lock parameter, to be sure the timing of the Loop doesn't change.

The Graphic Window

The graphic window at the bottom of the Edit Sample Loop page allows the Sample to be edited graphically. It contains four elements:

- A line of text, known as the "Legend", shows the current Sample's sampling rate and total length, in seconds and bytes. (Samples that are loaded from S-550 disks have a sampling rate of 30 kHz, so don't get confused if you see "30" in this line. They can be treated just like any other Samples.)
- A dark field, known as the "Loop field", which contains three horizontal light lines or rectangles, and which changes as you change the Loop Mode. These lines show the placement of the Start point and the length and placement of the Sustain and Release loops, relative to the entire Sample in memory. Adjustments can be made to the various Parameters right in the Loop field using Function keys - we'll get to these in a moment.
- A drawing of the actual Sample waveform, known as the "Waveform display".
- Another line of text, the "Title", which describes what the Waveform display is showing.

The Waveform Display

The Waveform display is the most important part of the graphic window when it comes to editing Samples. It can give you a graphic overview of the entire sample and can also provide precise visual feedback when editing and designing loops and other Parameters.

As mentioned earlier, the X-Zoom and Y-Zoom parameters determine the horizontal and vertical magnifications of the Waveform display. When X-Zoom is set to x1, the entire sample appears, and the Title at the bottom of the display says "ALL". (The Y-Zoom setting has no effect when X-Zoom is x1.)

Setting the X-Zoom value to anything else changes the display significantly. The display will show a vertical line in the center (the "loop point"), with the beginning of the loop to the right of the line, and the end of the loop to the left.

Making it Sound Good

For a loop to repeat in a useful way, without clicks, buzzes, or sudden volume changes, the beginning and end of the loop must be matched carefully as to level, wave shape, and slope. You can adjust the loop point with the Loop and End parameters, and look at the Waveform display for the smoothest possible transition. Increasing the value of Loop slides the waveform on the right-hand half of the display to the left (since it starts later), while decreasing the value slides the waveform to the right. Increasing the value of End slides the waveform on the left-hand half of the display to the left, and decreasing it slides it to the right.

It's considered good practice to have the loop point occur where the instantaneous level of the waves on both sides is zero (that is, on the horizontal line in the center of the Waveform display), which is known as a "zero-crossing" point. Sometimes, however, this is impractical, in which case as long as the slopes of the two waveforms match and form a continuous wave which looks the same on both sides of the loop point, the loop can often work.

In the Alt mode, because the waveform "turns around" on itself at the loop points, the best loop points are not at zero-crossings but at zero-slope points, such as peaks or troughs, where a mirror image of the waveform resembles as closely as possible the waveform itself.

Make sure Loop Mode is set to one of the modes in which the loop repeats, and hold down a keyboard key (or a MIDI key). Listen to the loop adjust itself as you move the loop point. As you get closer, lower the Edit Step value. To find the perfect loop point, it will probably be necessary to go all the way to 1. Increase X-Zoom to the next level if you need to see what's going on more precisely. If at the higher magnifications the waveforms seem to flatten out (because their level might be low), raise the value of Y-Zoom to increase the vertical scale.

You can adjust the Release loop in the same way. Set the Loop Mode to Fwd+R to enable the Release loop, and KeyOn Mode to R-Loop so that you can hear what you are doing.

As you change the X-Zoom value and adjust the various loop Parameters, the Title below the Waveform display will change to reflect what you are doing. For example, as you adjust the Loop parameter, the Title will read "Loop/Loop". As you adjust the R-Loop parameter, the Title will read "Loop/R-loop".

Point Mode

There is a second mode for displaying the waveforms in a Sample. This mode is enabled by setting the Disp Type parameter to Point. It is used when trimming the beginning and/or end of a Sample.

The Waveform display will no longer show the loop beginning and end side by side, but instead will show just one section of the sample. Which section it shows is determined by the cursor position. If you put the cursor on Start, the display will show the beginning of the sample, in whatever magnification you've chosen, with the position of the vertical line corresponding to the Start value - if it is Ø, the waveform will appear entirely to the right of the line. The Title will change to "Point/Start".

This display mode allows you to set the Start point precisely at the beginning of the actual sound, the importance of which we mentioned earlier. It can also help you put the Start on a zero-crossing point, to avoid clicks when the sound starts, which can be an issue when using the Sample with a fast TVA attack. In addition, Point mode can help you set the end of the sample right where the sound ends, so the DJ-70 doesn't use up voices playing silence.

Editing in the Loop field

While the Waveform display is useful for zeroing in on small sections of the Sample, the Loop field at the top of the window shows what is happening with the Sample in a larger sense.

The dark Loop field itself shows how much of the Sample will actually be played when a MIDI key is struck. It extends from the Start value (or Loop, whichever is lower) to the end of the Sustain loop, or if the Release loop is engaged (that is, if the Loop Mode is Fwd+R or Fwd+One), it will extend to the end of the Release loop.

The first line in the field, which is light and three pixels high, shows the length of the Sample including the active loops. This will be the same as the overall length, except in the Fwd+One mode, in which case the line cuts off at the beginning of the Release loop.

The second line represents the Sustain loop. If the Loop Mode is set so that this loop repeats, it will appear as a long rectangular box. If the mode is set so that this loop only plays once (OneShot or RevOne), it will appear as a single-pixel line with short vertical lines at the beginning and at the end.

The third line represents the Release loop. If the Loop Mode is set so that this loop repeats (Fwd+R), it will appear as a long rectangular box. If it is set so that it plays only once (Fwd+One), it will appear as a three-pixel line. In all of the other modes the Release loop doesn't play at all, but it still shows up, as a single-pixel line with short vertical lines at the beginning and at the end.

Advanced Loop Editing

A different and more elaborate approach to loop editing is found on the Edit

Looping in Stereo

An interesting feature of the loop-editing function is that you can set up different loops for the two halves of a stereo Sample. This can be very useful for producing chorusing effects, or when working with long "phrase" Samples, for doing Steve Reich-style composition.

Normally, when you are working with Edit Mode set to Stereo, any loop editing you do on one half of the Sample will affect the other half in exactly the same way. However, if you set Edit Mode to Mono on one half, you can set a loop for that half which will not affect the other half. Any of the Parameters on the page, including Loop Mode and Length Lock, can be modified.

Once you've done one Mono change, you can then, if you like, go to the other half of the Sample, and set Edit Mode to Mono and do the same thing. When the loops are set, you can reset the Edit Mode to Stereo, and the two halves of the Sample are once again treated as a stereo Sample - when you play one, both will sound.

Beware, however, that as soon as you leave one Sample (to select the other half, or any other Sample), the Edit Mode will automatically be reset to Stereo, no matter how you left it, and when you come back to that Sample, you will find it set to Stereo. You must be careful: if either of

the halves of a stereo Sample is in stereo Edit Mode, then should you change any loop Parameter, it will cancel all of the differences between the two halves, and make all of the Parameters of the other half conform to the Parameters of the current half.

Looping tricks

Making good Sample loops is as much of an art as anything in music production, and there have been many thousands of words written about the subject in many books and magazines. If you would like to improve your looping skills, search them out, and practice, practice, practice!

In the meantime, here are a few ideas that might help.

Long loops are better than short loops, because short loops often impart a “periodicity” to the sound. But long loops can be trickier, because waveforms do change over time. The Smoothing function (discussed next) can help.

If you plan to loop a Sample, it should be recorded as dry as possible, without reverb, chorusing, etc. A dry sound is a simple sound, and a simple sound is much easier to find good loop points in.

Finding a truly stable group of waveforms in a sample to make a loop out of might not always be possible. If that’s the case, loop a short section (just a few cycles) of a complex part of the Sample, and use the Partial’s TVF to filter out the higher harmonics over time, making the sound “settle down” as it progresses.

Smoothing

Sometimes finding the best possible loop point using the visual Waveform display still does not produce a usable loop. This could be because the waveforms at the beginning and end of the loop are so different that the sudden change causes a glitch, which then occurs regularly as the loop repeats.

To overcome this problem the DJ-70 includes a “Smoothing” function, which irons out waveform differences at loop points. It does this by taking a number of bytes at the very beginning and very end of the loop and mathematically interpolating them so they are as identical as possible at the loop point. It also interpolates the bytes at the beginning of the loop point with the bytes before the loop point, to make sure there is no glitching when the loop starts.

Smoothing is available in Edit Sample Page functions. Use the SHIFT - F4 button to get to the Edit Sample Smoothing page.

Select the Current Sample at the top of the page. The Edit Mode and KeyOn Mode parameters are the same as on the Loop page. The Orig Key parameter can be used to change the placement of the sample’s original pitch on the keyboard. This is useful if you want to change the keyboard range of the sample.

The Edit Step parameter determines the resolution of any parameter changes you make. The Remaining parameter shows how much RAM is available. Since you are over-writing the same Sample, this parameter is not very important, except if you need to undo the Smoothing operation, which is discussed below.

Setting the Smoothing Length(s)

The degree of smoothing is determined by the Loop-Smoothing Length and R-Loop-Smoothing Length parameters on the right side of the Lcd. These Parameters show the number of bytes at the beginning and end of the loop that will be interpolated. A small number means the actual waveforms in the loop will be altered relatively little, and the sound in the loop will maintain most of its original character. However, if the number is too small, you may still hear a “bump” in the sound as the loop repeats. A large number means the loop will be more “homogenized”, and have more of a steady sound as it repeats.

If Loop-Smoothing Length is set to 1, the Smoothing operation will not execute - you can't smooth out just one byte. However, if you want to Smooth the Sustain loop and not the Release loop, set R-Loop-Smoothing Length to 1.

For obvious reasons, there must be a loop set up on the Loop page for Smoothing to take place - if there isn't, you will not be able to adjust any of the Parameters on this page. You can move freely between this page and the Loop page pressing the Shift button together to the relative Function key, and if you change a loop's length on the Loop page, that change will show up immediately on this page. Note that a Sample can only be Smoothed if its Loop Mode is Forward or Forward+R. If the mode is set to something else, then performing the Smoothing operation will automatically change the mode to one of those two.

Also for obvious reasons, you cannot set a Smoothing Length longer than the loop itself. In addition, if the Sustain loop starts early in the sample, you cannot set a Smoothing Length that would cause the Smoothing operation to start before the beginning of the Sample. So a loop that starts at 7560 cannot have a Smoothing Length greater than 7560.

Similarly, you cannot set a R-Loop-Smoothing Length which would cause the Release loop-smoothing operation to cross into the Sustain loop. If, for example, the Release loop begins 128 bytes after the Sustain loop ends, the maximum value for R-Loop-Smoothing Length will be 128. If the Release loop starts immediately (10 bytes) after the Sustain loop, you cannot smooth it at all.

Executing the Smooth

Press the Execute Function switch. The legend in the graphic window says “New”, tells you the length of the new Sample (which should be the same as the current Sample), and whether it is stereo or mono. Select, and the Smooth is accomplished. Play a MIDI key and hold it down long enough for the loop to repeat a few times to hear how effective the Smoothing has been.

Recovering from a Bad Smooth

The Smoothing operation is destructive, which means that, unlike the looping operation, it changes the Sample in RAM by actually altering the values of individual bytes within the Sample.

Fortunately, for those of us who occasionally make mistakes, it is easy to “undo” a smooth that turns out badly. Merely press the “Recover” button, and the current sample is returned to its previous, un-smoothed state. If you want to smooth it again, either with the same parameter settings or different ones, press Execute again. You can do this as many times as you like. The Recover function will, however, only undo the last execution, so if you smooth a Sample twice, you can only Recover from the second operation.

If the Remaining parameter is less than the length of the Sample, you will not be able to Recover from a Smooth, because the DJ-70 has nowhere to store the recoverable Sample. If this is the case, a warning box will open after you click Execute, telling you that you won’t be able to Recover, and asking if you want to go ahead anyway. If you need to be able to Recover and don’t have enough room Remaining, go to the Com menu and Delete one or more spare Samples from RAM.

Chapter 7: Sampling 2 - Editing and Resampling

In the last chapter, we dealt with recording Samples and editing them in primarily non-destructive ways. In this chapter we will look at the more radical ways you can work with DJ-70 Samples.

Normalizing is done from its page in the Edit Sample function. Truncating can be accessed on its page in the Edit Sample function.

Normalizing

Normalizing increases the signal level of a Sample. It is useful when a Sample has a limited dynamic range, perhaps because it was recorded poorly, or the loudest parts of the sample were truncated out, leaving only softer parts. As with all audio recording systems, it's a good idea to have the samples in RAM and on disk at the highest possible level, to maximize the signal-to-noise ratio. Also, having all the samples at roughly the same levels makes it easier to mix them in a Partial. Normalizing is available when you record a sample initially (see the previous chapter), as well as with some other operations (described later in this chapter), but it is also available as a separate feature for working on samples after they are already in RAM.

Normalizing ensures that a Sample is at maximum level by first searching through the Sample and determining its loudest point, then raising the level of that byte to the maximum level possible, and multiplying the level of every other byte in the sample by the same factor. This increases the overall level of the Sample without changing it in any other way.

To get to the Normalize page, go to the Edit Sample function, press and hold down Shift button and F5. The page is very simple to use. Besides choosing the Sample, the only Parameters to adjust are Orig Key, Edit Mode, and Name, all of which function the same as on the other Sample Edit pages.

As with Smoothing, which is also a destructive operation, you can Recover if you change your mind after Normalizing. If there is not enough memory Remaining to duplicate the current Sample, however, you will not be able to Recover.

Truncating

We saw in the last chapter that you can prevent sounds from playing at the beginning or end of a sample, by adjusting the Start and End points in the Loop pages. This makes it easy to eliminate extraneous sounds like microphones being switched on, producers knocking over equipment,

etc. Because Looping is non-destructive, however, those heads and tails are still part of the Sample, and are taking up room in RAM and on disk.

To use memory most efficiently, particularly on long Samples that you are only using a part of, it can be very helpful to be able to permanently trash those unneeded bytes. While the DJ-70 has plenty of RAM to work with, it is not unlimited, and efficient use of it is important. In addition, shorter Samples are easier and faster to deal with. Samples can be permanently shortened with the Truncate feature.

There are two ways to Truncate a Sample: the quick way, and the fancy way. The quick way is on the Edit Sample Truncate Page in the Edit Sample1 function. We'll look at that first.

The Truncate Page

At the top of the page, you select the Sample you want to truncate. You can of course rename it.

Orig Key lets you retune the base note of the Sample as you truncate. Edit Step sets the resolution for adjusting the numerical Parameters. X-Zoom and Y-Zoom set the horizontal and vertical magnification of the Waveform display. Orig Length shows the length of the Sample in its current state, while New Length shows how long it will be after you Truncate. The Remaining Parameter shows how much space is left in RAM; if this Parameter is lower than New Length, you won't be able to Recover the operation.

If the Sample is stereo, you can truncate both sides simultaneously if Edit Mode is set to Stereo. However, if it is set to Mono, because the Truncate operation is destructive, it will permanently break the link between the two halves of the Sample. The halves can be rejoined only if you then truncate the other half of the Sample (also in Mono mode), so it is exactly the same length, and then re-link the two halves using the Set Stereo command.

Setting the Truncate Points

The Parameters that you want to deal with are "From", which sets the truncation point at the beginning of the Sample, and "To", which sets the truncation point at the end. If you don't want to truncate the beginning, set "From" to \emptyset ; if you don't want to truncate the end, set "To" to the highest number you can.

The minimum number of bytes in a Sample is 4608, which is just about 0.1 second, or 0.2 second at the lower sampling rate. If you set "To" so that it is less than 4608 bytes after "From", it will be ignored, and the Sample will end up 4608 bytes long, starting at "From".

To help you set the "From" and "To" parameters and let you audition the operation before committing to it, two additional KeyOn Modes are available on this page: **From/To**, which plays the Sample from the "From" to the "To" bytes, and **To**, which plays starting at the "To" byte, so you can hear what it is you're losing at the end.

Fading the End

You can impose a smooth linear fade on the end of the Sample while you are truncating it. The length of that fade, in bytes, is determined by the Fade Len parameter. The fade will start at the byte whose value is equal to the To parameter minus the Fade Len parameter. For example, if To is 1000 and Fade Len is 250, the fade will start at byte number 750.

A fade cannot start any earlier than halfway through the truncated Sample, so the maximum value for the Fade Len parameter is the overall truncated length (the To value minus the From value), divided by 2. So for example, if From is 200 and To is 1200, the maximum allowable value for Fade Len will be 500. If you change the From or To point to shorten the Sample such that the truncated length would end up being less than twice the Fade Len, the Fade Len will automatically shorten.

The Graphic Window

Adjustment of the Truncate points and Fade Length can also be displayed in the graphic window. The top line in the dark field at the top of the window shows the From and To points. The second line, is the Fade Len. The right side of the rectangle cannot be moved — it is locked to the right end of the line above it. Below the Fade Length line is a line showing the overall Sample length, and below that two lines showing the locations of the Sustain and Release loops, for reference.

The Legend immediately above the waveform display describes the position of the From and To points relative to the other points in the Sample. If one of the points falls exactly on another, it will be displayed with an “=” sign — for example, if the From point is the same as the Sample Start point, the Legend will say “F=S”. If there is no exact correspondence, the Legend will show which points the From and To points fall between — for example, “S<F<L” means the From point is between the Start and the beginning of the Sustain Loop; “RL<T<RE” means the To point is between the beginning (R-Loop) and End of the Release loop; and so on.

The Waveform display itself is always in Point mode, and shows (except when X-Zoom is set to x1) the From or To point, depending on which one was selected most recently, at the current magnification. The Title will show which point is being displayed. If X-Zoom is at x1, it will say “All”, and during graphic editing the Title will say “Get =” and the Parameter being adjusted.

Recovering

Like Smoothing and Normalizing, Truncating is a destructive edit, and so a Recover function key is available to undo a Truncate operation. The Recover switches on all of the different Edit Sample pages are linked. This means that if you do an operation on the Truncate page and then go to the Smoothing page and only then realize you made a mistake, no worries: use the Recover switch on the Smoothing page, and the Sample will return to its previous state. Obviously you cannot Recover a Truncate once you’ve done a Smooth, or done any operation on a different Sample. Nor can you Recover any operation after you’ve gone to any Disk page. But you can Recover a Sample if you’ve left the Edit Sample level, to go to a Patch or Performance, for example, and come back to it.

Truncating Looped and Stereo Samples

Truncating can drastically change the characteristics of a loop, so it is advisable to do it in a Sample without loops, or else be prepared to redo your loops afterwards. If you truncate a Sample so that the new end of the Sample (the To parameter) falls inside a Release loop, the Release loop will be shortened so that it ends when the truncated Sample ends. This will throw all the careful loop-point editing you've done on the Release loop out the window. If the To parameter falls within a Sustain loop, the Sustain loop editing will be rendered essentially worthless, while any Release loop will be totally eliminated.

If you Truncate and Reverse a Sample with loops, the loops stay at their original locations, so what was previously the beginning of the sound will now be a looped tail.

If you set up a Fade so that the fade point falls within a loop, the loop points will be maintained, but because the level at the end of the loop will now be lower than the level at the beginning, there will be an audible glitch every time the loop repeats, and you will probably not want to use it.

Truncating a stereo Sample requires special care. Although there is no stereo/mono switch on this page, the software knows when Source Sample1 is part of a stereo pair. If the Dest Sample is also part of a stereo pair (it can be the same pair or a different one), then the Truncate operation will work on both halves of the pair. If Dest Sample is mono (which will also be the case if it is Blank), then only the half of the stereo Sample showing as Source Sample1 will be truncated. The other half will be unaffected, and the link between the two halves will be broken.

If you want to Truncate a stereo Sample into a new Sample, you must first create a "dummy" stereo Sample on the Sampling page. Although it needs to contain no actual audio, and you can make it as short as you like, you must name and record this dummy Sample in the normal way.

If you were brave (or perverse) enough to set up a stereo Sample with different-length loops as outlined in the previous chapter, you should know that such an arrangement will not survive a Truncate operation. When you Truncate, the loops re-align themselves, and the loops on the half of the Sample that is Source Sample1 will be applied to the other half of the Sample.

Time Stretch

The DJ-70 can alter the length of a Sample without changing its pitch, or vice versa. A Sample can be sped up or slowed down by up to a factor of four. This operation is useful in a variety of contexts. It can be used to fit dialog, sound effects, or a musical phrase into specific periods of time, especially in film or video production or to synchronize two different riffs without changing their pitch. It can change the rhythm or length of a musical phrase to conform with a sequenced or recorded rhythm track. And it can be used to great creative effect, to transform familiar sounds into unfamiliar ones, or to create totally new sounds.

Time Stretching is handled on the Time Stretch P(arameter) Page, selected from the Edit Sample2 submenu. The top line is for choosing the Sample to work on. The operation works on a

Sample in place, so if you want to keep a copy of the unaltered Sample, use the Copy function from the Com menu before executing.

Let's skip the first few Parameters for now — they are used if you don't want to Stretch the whole Sample. Do, however, look at the “—Time” Parameter. This tells you the length, to the nearest millisecond, of the current Sample.

Ratio

Ratio sets the stretching factor, which can be from 25% to 400%. Ratios less than 100% speed up the Sample and make it shorter, while ratios greater than 100% slow it down and make it longer.

As you adjust Ratio, you'll see the numbers in the blue box on the right half of the screen change. They are showing you what will happen to the pitch, the length in bytes, and the duration in seconds of the Sample at the selected Ratio. If the ratio, for example is 150%, then the length and duration will be 1.5 times that of the original.

Select Execute to do the change. As usual, you can Recover the original Sample if you don't like what you've done, provided there is sufficient memory Remaining.

If there are any Sustain or Release loops in the Sample, they will be stretched or shrunk accordingly, so they should sound the same in the new Sample as they did in the original. Changing the KeyOn parameter lets you listen to the different parts of the Sample so you can check this.

Fade

When a Sample (meaning a sound) is Time-Stretched, the software takes “chunks” of the original Sample and interpolates, crossfades, and creates many new samples (meaning individual bytes) to put into those chunks. The size of the chunks is determined by the software (invisibly to the user), and the Fade parameter determines how much the chunks will be overlapped when the new sample bytes are calculated. Generally speaking, the larger the fade, the smoother the resulting sound. However, the operation also takes longer with longer fades. Simple sounds, like sine waves, will stretch fine with low settings of the Fade parameter, while complex, reverberant sounds will need higher settings if they are not to come out sounding weird.

When Mode is set to Manual, you can adjust Fade as you like. E.Step, as usual, changes the resolution of the adjustment.

Life, however, is not quite that simple — it's not enough just to set a high value for Fade, it also has to be just the right value for the particular sound. For you to find that value could require hours of trial and error. Fortunately, the DJ-70 can help. When you select Search, the DJ-70 calculates a new set of chunk sizes that might be appropriate for the current Sample, and resets the Fade parameter to accommodate the new chunks. When it's done, you can select Execute and listen to the result. If you don't like it, select Recover, then Search again, and try the next set. (If you find a Fade value that “sort of” works, you might want to save the stretched Sample under a new name, just in case nothing better comes along.)

For the ultimate in assistance, change Mode to Auto. Now you can't adjust Fade at all, and Search is disabled. When you select Execute, the DJ-70 looks through all possible chunk sizes, and decides which one it likes best. It then executes the Time Stretch using that number. While this process consistently yields the best results, the software algorithm it uses is extremely complex, and so there's a trade-off: it can take a while. With complex sounds, the operation might take as long as 100 times the length of the Sample.

Pitch Change with Constant Length

This operation works just as well if you want to do the opposite to a Sample: alter its pitch without changing its length. This can be useful for creating unusual vocal or sound effects (Darth Vader comes to mind), or fattening a Sample by doubling it at a different pitch. While the same operation is used, the information you need to know is different.

The pitch numbers in the dark box will tell you how far the pitch of the original Sample will deviate for a given Ratio. If you then want to play the new Sample so that it fits into the same time as the original, you will have to change its pitch by the numbers displayed: in half-steps (Coarse) and 1/100ths of a half-step (Fine). Use Ratios above 100% for creating higher-pitched versions of the Sample, and Ratios below 100% for lower-pitched versions.

Here's an example: you have sampled a piece of dialogue matched to picture. The actor's voice is wimpy and you want to lower it by a major third. Select the Ratio parameter, and hold down the S1 button to lower it. Watch the pitch parameters change. Set the Ratio so that the Coarse parameter says -4 (four half-steps is a major third) and the Fine parameter is as close to zero as possible. We'll save you some suspense: the Ratio will be 79%, and Fine will be -8, which is pretty good. Now Execute.

If you now play back the new Sample from the MIDI keyboard a major third lower than the original key, the pitch will be indeed lowered a major third, but the length (and rhythm) will be very nearly unchanged.

To get a closer match, load the Sample into a Partial, where it can be more finely tuned: set the C.T in the Partial to -4 and the F.T to -8, and play it back on the original key. The new Sample will match the timing of the old perfectly.

The same technique can be used to "harmonize" a Sample: create three different versions of a vocal or instrumental Sample at three different pitches, and you've got an ensemble.

Stretching Part of a Sample

If you only need to stretch or shrink a part of a Sample, you can set the limits of the operation using P1:From and P2:To. Only the portion of the Sample between those two points will be affected. Setting KeyOn to FromTo lets you hear the region you've set up.

If you happen to know exactly how many bytes (or seconds) the stretch region should be, you can use the Length parameter to set it up. When you change it, the "P2:To" point changes along with it. "P1:From" won't move.

Rate Converting

The situation often arises in which it is necessary to give a Sample a different sampling rate. For example, as we discussed earlier in this chapter, if you Mix, Combine, or Insert two Samples that are recorded at different rates, one or both of them will change pitch. If you change them so the rates are the same, there is no pitch change.

Another situation that might call for sample-rate conversion is if you have a lot of long, high-sampling-rate Samples in RAM which don't really need to be at that high rate, and therefore are taking up more space than necessary. By down-converting these Samples, you can free up more memory, hopefully without sacrificing sound quality.

Or, you may have a Sample that needs to be transferred to another sampler or a computer via MIDI Sample Dump, but the receiving device can only deal with samples at certain rates, and your Sample is at the wrong rate. Converting it internally assures a perfect transfer.

There are four sample rates available: 44.1, 30, 22.05, and also 15, which should only be used for truly low-fi sounds.

The operation is straightforward, and is done on the Edit Sample Rate Convert Page, of which there is only one, selected from the Edit Sample2 submenu. Select the Sample to convert at the top of the page. Its Original Key and Wave Length (that is, the number of seconds of RAM it occupies relative to 44.1 kHz) are displayed. Go down under the word [New], and set Sampling Rate to the rate you want. The Wave Length (again, relative to 44.1 kHz) for the new version is shown.

Select and confirm "Execute" and it's done. Select and confirm "Recover" (assuming there's enough RAM available), and the Sample goes back to its original rate.

Retuning

If you like, you can change the Original Key of the Sample for conversion, thereby shifting the Sample up or down. You can do this while you're converting to a different Sampling Rate, but you may also find it helpful to change the Original Key while converting to the same Sampling Rate, just to bring the Sample into tune with other Samples. Resetting the Original Key can be done on many of the Sample Edit pages as we have seen, but this one has a twist: when you are working on a Sample, the Correct switch can analyze its absolute pitch, and guide you in assigning it a key. Selecting the switch doesn't change the Sample, it just analyzes it. After a short wait, the Pitch parameter will display the true musical pitch of the Sample, and any tuning offset in 1/100ths of a semitone.

For example, if you have sampled a musical sound at a pitch of 440 Hz (A above middle C), regardless of where you assigned the Sample's Orig Key, when you click on Correct, it will tell you the Sample should be at A_4. If you set the Orig Key to A_4, you'll have a Sample that's in tune with the rest of the world. (Of course, you don't have to re-assign the note.) Note that this feature only makes sense with musical sounds — if you try to Correct an unpitched sound, you may get an Error message, or you may get a real note, but it will not be much help.

Range Extension

Another interesting feature of this page is that it can extend the range of a Sample. Normally Samples can be transposed up a maximum of two octaves (three if they are recorded at a slower rate). With the Pitch Shift option on this page, however, Samples can have their range extended. Setting both Sampling Rates the same, and then setting Pitch Shift to 3 will raise the pitch of the Sample a minor third, and at the same time raise its upper transposition limit by a minor third.

If you want to extend the upper limit of the Sample without shifting its position on the keyboard, set the Original Key parameter to the same interval as Pitch Shift: if you want to extend the range a minor third, set Pitch Shift to 3, and the Original Key (assuming it is C₄) to D#₄. Now the Sample will play back at the same pitch, but you'll have an extra three half steps available at the top.

This operation is not without a trade-off. Pitch shifting a Sample upwards actually shortens it (the Wave Length parameter shows you this), and that means that the quality of the Sample isn't quite as good. If you go a long distance with Pitch Shift, you may be able to hear audible deterioration of the Sample at the original pitch.

Pitch Shift can be set as high as 48 (four octaves) for truly radical changes. The Fine parameter adjusts it in 1/100ths of a half-step.

Resampling

Samples can be combined, with various modifications applied, entirely in the digital domain within the DJ-70, using the Resampling function. Resampling is not one of the Sample Edit pages; it has its own set of pages, and is accessed directly from the Sound menu. It can also be accessed from the Index (select Resampling twice) or through a Jump page. Performance Resampling, the other item on the Resampling subtopic of the Index, is a special case that is discussed at the end of this chapter.

The resampling function takes two mono Samples — the Source Samples — and mixes them into one mono Sample. One or both of the Samples can be delayed or tuned relative to each other. Filter and volume (TVF and TVA) envelopes can be applied to one or both Samples. If a stereo Sample is selected as a Source Sample, only the half of the pair named will be included.

Resampling has many uses. Two identical Samples, slightly detuned, can be combined to create a “chorus” effect that only uses up one voice. Or they can be grossly detuned for harmonizing effects. Volume and Filter envelopes that sweep across the two source Samples, either together or in opposition to each other, can create very dynamic sounds. Because Resampling is done entirely on the digital level, with no conversion to analog, there is no generational degradation of the sound, and Resampled sounds can themselves be Resampled without problems.

Resampling Complex Events

Resampling involves “playing” the source samples from the Keyboard or from MIDI. If a Sample contains Sustain and/or Release loops, they will play as long as the key is held down and

the TVAs allow, just as if you were playing a Partial. The newly-created Sample will not have any loops of its own, but will treat those repetitions as part of the one-shot Sample itself. Sustain Pedal (Controller #64), Pitchbend, and other MIDI controllers are responded to as well, in accordance with the settings made the last time you were on the Edit Patch Ctrl page (or if you haven't been to that page since power-up, the default settings). As on the Edit Sample pages, the DJ-70 is in Omni mode on the Resampling pages.

In addition, multiple MIDI notes (up to the DJ-70's polyphony limit) can be played during the Resampling. Each incoming note triggers the Source Samples at the pitch corresponding to the note's pitch, and at a volume proportional to the note's velocity. All of the sounds thus generated become part of the new Sample. Therefore, a Resample can easily be made up of multiple copies of the Source Samples at different pitches, loudnesses, and/or times, which can be in the form of a chord, a "stutter", an arpeggio, or an entire musical phrase.

Timing, Tuning and Naming

The first Resampling page is Resampling Common. Here is where the Source Samples are chosen. Samples 1 and 2 can be selected from any Samples currently in RAM. If you only want to use one Sample (to make a chord or pattern out of it), set one of the Source Samples to Off.

Each Sample can be tuned, using C.T (in semitones, ± 4 octaves) and F.T (in cents, $\pm 1/4$ -tone). Small values of F.T give a flanging or chorusing effect. The triggering of either Sample can also be delayed relative to the other, using the Dly parameter. The range available is from a couple of milliseconds to several minutes.

The name of the resulting Sample appears at the top of the screen. You can overwrite an existing slot, or use a blank slot and give it a new name.

The Resampling Algorithms

The other item on the Common page is "Algorithm". As on a digital synthesizer, the Algorithm determines how the various source and processing modules that make up the Resampling function will be arranged, and whether the Source Samples will be added or multiplied.

Adding Samples does just what it sounds like: the two sounds are combined into one. This can be a very useful feature for layering sounds, in that fewer DJ-70 voices are then needed to produce the same complexity of timbre.

Multiplying Samples produces non-harmonic partials similar to a ring modulator. The result is a metallic sound, which, in moderation, can be useful for bell-like timbres or, in excess, for totally weird, sci-fi sounds. Keep in mind when two sounds are added together and one is at zero level, the other will come through, but when two sounds are multiplied together and one is at zero level, there will be no sound produced.

Besides the Source Samples, the algorithms give you two TVFs and two TVAs to work with.

- In Algorithm 1, each Sample has its own TVF and TVA, and the outputs of the TVAs are added.
- In Algorithm 2, the Samples are added first, then put through the two TVFs in series, and then through a TVA.
- In Algorithm 3 the Samples are multiplied, but before that happens, one of them goes through a TVA. The combined signal then feeds the two TVFs in series and the remaining TVA.
- Algorithm 4 is similar to Algorithm 3, except that the signal from Sample 2 (the one without a TVA), besides being multiplied with Sample 1, is also added to the product signal before it all goes to the TVFs. Unlike Algorithm 3, this algorithm can be used with just one Sample (Sample 2), giving it two TVFs to play with.
- Algorithm 5 takes the output of Sample 1 and puts it through a TVF and TVA, and then multiplies it with Sample 2, which has also been put through a TVF. The product then goes through the remaining TVA.
- Algorithm 6 is similar to Algorithm 5, except that the Sample 2 signal, after it passes through its TVF, is added to the product signal before it goes to the final TVA.

Filter and Volume Envelopes

The two TVFs are set up on the Resampling TVF page. These are simplified versions of the TVFs found on the Partial Edit page. (Remember, we're dealing directly with Samples here, so any envelopes set up at the Partial level will have no effect.)

For each of the two Source Samples you can set Filter Mode (Low-pass, Band-pass, or High-pass), Cut Off frequency, and Resonance, and design an envelope numerically. The filter has no "Off" position, so if you want to have no filter action, use the default settings: Mode = LPF; Cut Off = 127; Reso. = Ø.

The G-Edit parameter ("Graphic edit") determines which Sample's envelope will be frontmost in the graphic window at the bottom of the screen. If G-Edit is set to Sample 1, then Sample 1's TVF envelope will be frontmost in the graphic window, while Sample 2's TVF envelope will be dark. The two TVAs are set up on the Resampling TVA page. The Depth parameter for each Sample sets an overall loudness level for the envelope, so that you can balance the two. The envelope itself can be designed graphically or numerically. If you want no envelope action at all, set all of the Time parameters to 0 and the three Level parameters to 127 (Level 4 must always be 0). The G-Edit parameter again determines which Sample's envelope will be frontmost in the graphic window.

Final Preparations

The last set of Parameters to deal with before doing a Resampling are on the Resampling Other page. Here are a number of items that will be familiar from the Sampling page: sampling rate Frequency, Name, Time (don't be skimpy, but remember you can't set this higher than the Remaining time), and the Original Key the Sample will be based on when you play it back. As on the Sampling page, Time and Remaining are based on the current sampling frequency, not (necessarily) 44.1 kHz.

Turning on the Emphasis parameter boosts the high frequencies in the new Sample, which can come in handy in many situations, especially if you are using TVFs in Low-Pass mode. If there's not enough high end in a Sample, it's hard to add it later without introducing noise and

general grunginess, but if there's too much high end, it's easy to get rid of it at the Partial level with a Low-pass TVF.

There aren't really any adjustments you can make to the level when Resampling — the REC LEVEL, SENS, and VOLUME controls have no effect here. Play one or more notes on the MIDI keyboard (if you are recording a phrase, here's your chance to practice) and watch the Level box in the window respond. As you play the keyboard harder (more velocity), or add more notes, the level goes up. It is possible, although difficult, to make the level too high if you are playing a lot of notes. If this happens, you will hear the sound clip in the monitor. Try to play a little softer.

Do It

When you're happy with the way things sound, press the F5 function key named "Ready" to start resampling. A box saying "Wait Trigger" appears. As soon as you play the first note from the keyboard or via MIDI, the DJ-70 starts recording (pedal or controller movements, although they may affect the sound, will not trigger the recording). The "thermometer" to the left of the Level box will fill up as the Time gets used.

When the Resampling is finished, a "Now Working" box appears briefly, and then the Resampling Over window comes up. It shows the new Sample in a Waveform display window, and you can play the keyboard and hear what it sounds like. The new Sample, now resides in RAM under the name you've assigned it, and it can be used, edited, stored, and resampled just like any other Sample, the DJ 70 has also automatically created the relative partial and patch and has assigned it to a new performance.

Tricks and Warnings

Resampling provides a nice way to link two Samples together sequentially: set up the first Sample with a Dly of 0, and the second Sample with a Dly equivalent to the length of the first Sample. Since the Dly parameter is not calibrated in real-time units, this may require a little experimentation.

While we're on the subject of delays, the timings of the TVA and TVF envelopes are tied to the Dly parameters on the Common page. If the Delay for Sample 1 is set to five seconds, then TVA 1 will not start until five seconds after the MIDI key has been pressed. This is all well and good when the envelopes are operating directly on their respective Samples. However, in Algorithms 2, 3, and 4 the envelopes are not directly attached to their respective Samples. Therefore, you may possibly find yourself in a situation where a Sample has a short delay time, but the TVA controlling it has a very long delay time, and you end up hearing nothing, because the Sample is over before the envelope begins. Be careful.

Resampling can also be used to stretch the top end of a Sample's range. For example, set C.T on the Common page to 2, and play a Sample on its original key. It will now be transposed up a whole step, and the pitch range will be extended at the top by a whole step. You can re-position the new Sample to the correct pitch in one of the Edit Sample 1 pages, or within a Partial. This method isn't quite as clean as stretching the range on the Rate Convert page, because it doesn't preserve loops, and it takes into account your key velocity, but it will work in many circumstances, especially when you want to extend the range of a Sample and combine it with another at the same time.

Performance Resampling

We looked at Performance Resampling in the previous chapter, in terms of sampling from within a Performance. Now we'll talk about Resampling from a Performance.

The Performance Resampling page is accessed from a Performance Play Page by opening the Com menu and selecting Resample2, or from the Index.

As we've seen, if the Input parameter is set to Analog, this acts just like the Sampling page, recording signals coming in through the inputs, although there are fewer choices (triggering must be from a MIDI note, and monitoring is not available), but you do have the option to automatically Normalize the new Sample.

However, if you set Input to Internal, the page will resample sounds from within the DJ-70. The stereo outputs of the DJ-70 are effectively wired back into the inputs, without the signals ever leaving the box. If the Mode is Stereo, both outputs are routed back. If it is Mono, you can record either the left output (Int L) or the right (Int R). The physical output and input level controls do not affect the signal, but the Mix and Lev parameters on the Play Page do, as do all level and panning controls at subsidiary levels.

In ordinary Resampling, you are making a recording of simple playback of one or two Samples, with some rudimentary performance aspects applied. In Performance Resampling, you are making a recording of the DJ-70 in full operation, using multiple MIDI channels, and as many keys and controllers as you want to throw at it.

Although it is not visible, the entire Play Page you came from is completely active when you are on the Performance Resampling page. (If you came from the Index, the operating system actually brought you through a Play Page.) You can play the DJ-70 multibrally using multiple MIDI channels just as if you were on the Play Page itself, either from a single-channel MIDI source like a keyboard, or from a sequencer. It will respond to notes, controllers, program changes, pitch-bend, or any other valid data.

Select Ready, and after a few seconds (and appropriate warnings if you are overwriting existing data) the screen tells you it's waiting for a trigger. As soon as it receives the first note from the keyboard or from MIDI, on any channel (it doesn't have to be a channel that's active in the Current Performance), it will start recording. Now any sound that the DJ-70 produces will be captured as part of the new Sample.

When the time limit is reached (the thermometer fills up), the resampling stops. (You can also cut off the resampling early by pressing EXIT button.) Then you are taken to the Resampling over page, where you can play the result.

When you have finished, a new Partial and a new Patch, both with the same name as the Sample, are created. You are taken back to the Play Page, where you can load the new Patch right into a slot in the Current Performance.

Creating and editing Performances is the subject of the next chapter.

Chapter 8: Performances, Volumes, and MIDI Program Changes

A Performance contains all the information for making the DJ-70 a fully multitimbral, multi-channel, multi-output sound generator, capable of playing a single musical selection or an entire album's or film's worth of material. While a Patch is a single "instrument", responding on one MIDI channel to produce one kind of sound at a time, a Performance is a group of Patches all responding to MIDI at the same time, on the same or different channels. While several Performances can be loaded into RAM at a time, only one can be active.

A Performance is made up of from 1 to 31 "Parts", each of which contains a Patch and a MIDI channel assignment for playing that Patch on, as well as a few other Parameters. Patches assigned to a Part can be changed in real time over MIDI, using Program Change commands that are received on the Part's MIDI channel.

Creating a Performance

While there is one performance provided on the Demo disk that came with your DJ-70, to best illustrate their potential, let's create a new one.

Press the Disk button. Go to the Load page, and set Target to Patch. Select a patch, and click the S1 or S2 button to load it into RAM. If the screen asks if you want to clear all Internal Memory, select Yes.

When it's done, load other three patches, in any order, making sure you do not clear Internal Memory with each load:

[Play Page2 1/16						ComExt	
□ Perf 1: - empty -						A	B
						11.3	11.2
Splt	Patch	Name	Limits	Shift	Kb		
<input type="checkbox"/>	01	Off	C 2 C 7	0	On		
<input type="checkbox"/>	02	Off	C 2 C 7	0	On		
<input type="checkbox"/>	03	Off	C 2 C 7	0	On		
<input type="checkbox"/>	04	Off	C 2 C 7	0	On		
<input type="checkbox"/>	05	Off	C 2 C 7	0	On		
<input type="checkbox"/>	06	Off	C 2 C 7	0	On		
<input type="checkbox"/>	07	Off	C 2 C 7	0	On		
<input type="checkbox"/>	08	Off	C 2 C 7	0	On		
<input type="checkbox"/>	09	Off	C 2 C 7	0	On		
<input type="checkbox"/>	10	Off	C 2 C 7	0	On		
<input type="checkbox"/>	11	Off	C 2 C 7	0	On		
<input type="checkbox"/>	12	Off	C 2 C 7	0	On		
<input type="checkbox"/>	13	Off	C 2 C 7	0	On		
<input type="checkbox"/>	14	Off	C 2 C 7	0	On		
<input type="checkbox"/>	15	Off	C 2 C 7	0	On		
<input type="checkbox"/>	16	Off	C 2 C 7	0	On		

17/31 / Page3 / Lim L / Lim H / Sample

Groove 2
 Rap Fill
 Ahi Ahi

Now Press the Play button, and you will be back on the Play Page2. (If you're on a different Play page, press F2 button until you will be on the Play Page 2).

This Page shows the first sixteen Parts that make up the Performance. Each Part has a couple of Keyboard Limits , a Shift and the Keyboard On/Off setting.

Entering the Patches

Put a Patch into Split number 1 by putting the cursor on the first Patch field on the Page (it currently says "—Off—"). Press the S1 or S2 button, and the names of the Patches that you have just loaded into RAM will appear, one at a time. Assign the first patch to Split 1. Move the cursor down to the Patch field for split number 2, and press S1 or S2 until the second patch appears. Go to Split number 3, and set it to the third, and set Split number 4 to the fourth.

Setting the Keyboard Range

To assign to each of the split a keyboard range, simply put the cursor on anyone of the split fields, press and hold down the F3 button and press the keyboard key that you want assign to the low limit of the split.

Use the same procedure but pressing the F4 button to set the high limit of the split. Using together the two buttons F3 and F4 (High limit and Low Limit) you can set both limits at the same time. The same operation can be done directly putting the cursor on the parameters of the split (Limit Low/Limit High) and modifying the values using S1 or S2 button or Value Wheel. Press again the F2 button until you will be in Play Page 3.

Setting the MIDI Channels

The last column to the right of the Patch name shows the MIDI channel (Ch) for each Split. All the 31 Splits default to BS (Basic) MIDI channels, but you can change any of them you like, including setting more than one Split to a particular channel, thereby layering the Patches. You can also set the channel to "—", in which case the Part will not respond and trasmit to MIDI. Use this when you want to keep a Patch in a Performance for use at a later time. The notes received on the Basic MIDI channel are filtered through the keyboard setting to be assigned to each split.

[Play Page3 1/16				ComExt		
<input type="checkbox"/>	Perf	1: — empty —		A	B	
				11.3	11.2	
SpIt	Patch	Name	Lev	Pan	Pb	Ch
<input type="checkbox"/>	01	Off	127	0	Off	Bs
<input type="checkbox"/>	02	Off	127	0	Off	Bs
<input type="checkbox"/>	03	Off	127	0	Off	Bs
<input type="checkbox"/>	04	Off	127	0	Off	Bs
<input type="checkbox"/>	05	Off	127	0	Off	Bs
<input type="checkbox"/>	06	Off	127	0	Off	Bs
<input type="checkbox"/>	07	Off	127	0	Off	Bs
<input type="checkbox"/>	08	Off	127	0	Off	Bs
<input type="checkbox"/>	09	Off	127	0	Off	Bs
<input type="checkbox"/>	10	Off	127	0	Off	Bs
<input type="checkbox"/>	11	Off	127	0	Off	Bs
<input type="checkbox"/>	12	Off	127	0	Off	Bs
<input type="checkbox"/>	13	Off	127	0	Off	Bs
<input type="checkbox"/>	14	Off	127	0	Off	Bs
<input type="checkbox"/>	15	Off	127	0	Off	Bs
<input type="checkbox"/>	16	Off	127	0	Off	Bs

17/31 / Page1 / / P. Map / Sample

The notes received on a MIDI channel different from “Basic” are sent directly to the splits receiving on the same MIDI channel.

The Lev parameter controls the patch level and is affected by incoming MIDI Controller #7 (Volume) data, so when you send Controller #7 on a particular MIDI channel, you will see the Lev parameter change on any Split set to that channel. If you have two different Splits set to the same MIDI channel, they can have two different initial Lev settings, but as soon as you send Controller #7 on that channel, the two Lev settings will respond to the MIDI data and become identical. Remember the Lev parameter is an overall level for the Split.

Pitch Bender range

The PB parameter set the bender range for each split, it is used instead of the PB range parameter of the patch. It can be set from 0 to 48 semitones. If you set this parameter to “Ptc” then the patch PB range setting is used. Setting this parameter at “V>” or “V<” you can use the bender lever to control the volume of the patch moving it at right or left. This setting allows you to use the bender lever as fader between two patches simply setting in one split “V>” and in another “V<”. With the bender lever in central position the two patches are heard together at a level corresponding to the split level set for the split. Moving the bender right, a patch will be set at zero and the other will be set at 127; in the other side we obtain exactly the opposite. Press again the F2 button until you will be in Play Page 1.

Assigning a patch to a Pad

Put the cursor over the patch name that you want to assign. Press and hold down the Pad assign function key (F3) and press the pad which you want to assign the patch to. In the Play page “Pad” Field indicates the letter related to the assigned pad. Assigning a patch to the H pad it is assigned also to the scratch wheel.

Patch Loop mode

This parameter is an overall parameter, thus the patch is read using this parameter instead of the sample parameter. If it is set to “Smp” then the patch is read using the “loop mode” sample parameter. Loading S-770/750, S-550/330, W30 sound this parameter is automatically set to “Smp” to maintain the same loop mode of the original sound.

[Play Page1 1/16				ComExt	
□ Perf 1: - empty -				A	B
				11.3	11.2
Split	Patch	Name	Mode	Pad %	Mem
□ 01	Off		Fwd	-	0 -
□ 02	Off		Fwd	-	0 -
□ 03	Off		Fwd	-	0 -
□ 04	Off		Fwd	-	0 -
□ 05	Off		Fwd	-	0 -
□ 06	Off		Fwd	-	0 -
□ 07	Off		Fwd	-	0 -
□ 08	Off		Fwd	-	0 -
□ 09	Off		Fwd	-	0 -
□ 10	Off		Fwd	-	0 -
□ 11	Off		Fwd	-	0 -
□ 12	Off		Fwd	-	0 -
□ 13	Off		Fwd	-	0 -
□ 14	Off		Fwd	-	0 -
□ 15	Off		Fwd	-	0 -
□ 16	Off		Fwd	-	0 -

17/31 / Page2 / Pad As / P. Map / Sample

Patch Speed (%)

This parameter reproduce the speed control used in the analog turntable, it can be set from -15% to + 15%.

This parameter can be used to synchronize two or more patches.

MEM info

This value indicate the position of the sample in the memory.

If “A” is displayed, it means that the samples contained in the patches are located in the “A” memory zone; “B” means that the samples are located in the “B” memory zone.

A Performance can have up to 31 different Splits, each with its own Patch. Splits 17-31 can be accessed pressing the F1 button. Although in our example, we have loaded the Splits in strict numerical order, there is no requirement that you do so, so feel free to load any of the 31 Splits in any order you like.

If you want to create different Performances using the same set of Patches already in RAM (for example, you want to try a different set of Patch Speed or Pan positions), you can select a new blank Performance (scroll to an empty Performance slot, or use the Select icon and then choose “Blank”). If you want to save a Performance, make sure you Name it first.

The fifth Function key in this function, Part Map, we’ll come back to a little later.

Performance Editing

On the Play pages, you can put Patches into Parts and set basic Parameters. Another set of Pages, Edit Performance, is for setting up MIDI limits and crossfades for the various Patches in the Performance. Go back to the Performance menu (click on Exit) and select Edit Performance. (Or use Page1 of the second Jump set.)

The Common page shows you many information about the Performance status (Master Tune, Master Freq, number of samples, partial, patches) and gives you the possibility to Name the Performance and the Volume.

The next page, Performance Page1, is where the action is. (Note that you can press F2 to get to it — don’t be confused: in this Function F2 opens Page1, F3 opens Page2, etc.)

There are eight Parts visible, and you can assign each one a Patch and a MIDI channel. (The space available for the Patch Name is slightly shorter than on the Play page, so some names may get truncated.) Any changes you make on this Page will be reflected on the Play page, and vice versa. Parts 9 through 31 appear on Pages 2, 3, and 4.

Also as on the Play Page, an arrow will appear to the left of a Part number when Keyboard or MIDI data is received on its channel, and notes on active MIDI channels are displayed on the graphic keyboard. The display is in Omni mode.

Keyboard Splits and Fades

A Part does not necessarily have to play over the entire MIDI range — even if the Patch it contains is set up to do so. The Parameters on this Page are for assigning different Parts to different areas of the MIDI keyboard. As on the Patch Split page, different sounds can be set to respond to specific MIDI note ranges, but the setup here is a little different, and so is the way the splits are used.

Performance-level splits are most often used with different Parts and Patches assigned to a single MIDI channel. However, there may be times when you might want to use a split simply to limit a sound's range without putting another Patch on the same channel. The DJ-70 places no restrictions on how these splits are set up.

L.P stands for “Lower Point”, which is the lowest MIDI note a Part will respond to. U.P, not surprisingly, is “Upper Point”, or the highest note. They are both adjustable over the DJ-70's normal MIDI note range, A_Ø to C_8.

Unlike Patch Splits, on this Page you can set the various keyboard regions to blend into each other. L.W is “Lower Width”, which describes a “fade width” region. The value of the Parameter is the size of the region, in semitones above the Lower Point. Notes within the Lower Width region will sound progressively softer as you go down the scale, and when you go past the Lower Point, they do not sound at all. For example, if L.P is set to C_3 and L.W to 12, then notes above C4 (12 semitones above C3) will play normally, notes from C4 to C3 will play progressively softer, and notes below C3 will not play.

Similarly, U.W is “Upper Width”, and describes a fade width in semitones below the Upper Point. If U.P is A_6 and U.W is 7, notes below D6 (which is 7 semitones below A6) will play normally; notes from D6 to A6 will get softer as you play higher; and notes above A6 will make no sound.

You cannot specify a fade width that is larger than the entire active keyboard region of a Part, so for example, if the Upper Point of a Part is G#6 and the Lower Point is G#4, the maximum you will be able to set either L.W or U.W will be 23. Similarly, the sum of the fade widths cannot be larger than the Part's active region, so using the same example, if L.W were set to 14, the maximum you could set U.W to would be 9.

You can set the Point and Width parameters by selecting them with the cursor keys, and entering the value with the , S1 or S2 buttons or VALUE wheel with which you can enter the MIDI note number (A_Ø = 21; C_8 = 110).
Using the Splits

This feature can be used to set up “positional crossfades”, in which you spread Patches across the keyboard without the “brick-wall” splitting that is done within a Patch. To make it work, set complementary Points and Widths in two different Parts that are assigned to the same MIDI channel. For example, set up the Performance as described earlier, but set the MIDI Channel for both Parts 1 (piano) and 2 (harp) to 1. Set the U.W for Part 1 to 86 (the maximum) and the L.W for Part 2 to 86. Now you have a new instrument that is a piano at the bottom, a harp at the top, and a combination of the two in the middle.

A note on using Program Changes

We'll have a full discussion of MIDI Program Changes later in this chapter, but at this point it's worth noting that when the DJ-70 is in Performance mode, it receives and acts on Program Change commands on a channel-by-channel basis. Therefore, if two Parts are set to the same MIDI channel, and a Program Change command is received on that channel, both Parts will change Patches to reflect that Program Change. (The correspondence between Program Changes and DJ-70 Patches, you will recall, is handled on the Patch Common Page. It's also dealt with on the Patch Map page, coming up.)

This is all reasonable, unless you have set up two Parts with a positional crossfade between two different patches on the same MIDI channel. If you then send a Program Change command on that channel, the two Parts will change to the same Patch, with the same Pan and Output settings, which will render the crossfade (although it will not change) meaningless. So be careful.

Saving a performance

Performances are saved the same way as Patches, Partials, and Samples: from the Panel select Disk button, and then go to the Save page and select Performance as the Target. All Performances in RAM will appear in the window, along with their size (in sample-seconds, referenced to 44.1 kHz).

If you have been working on a new Performance and have neglected to give it a name, you will not be able to save it with just the temporary reference number assigned it by the software (if you try, you'll get a "File not found" error message). Don't be lazy: name it.

When you save a Performance, all of its subsidiary files are saved with it.

Note that only the Patches that are currently in Splits are saved when a Performance is saved. If you change the contents of a Part using a MIDI Program Change command, say from piano to guitar, and you then save that Performance, the piano Patch will not be saved, unless it happens to also be in another Part in the same Performance. It's important, therefore, if you plan to use a lot of Program Changes to switch Patches, to make sure that every Patch you plan to use has a Split to call its own. Use all the extra Parts on Pages 2 if you need room. If you don't want those Parts to sound when you first load the Performance, simply set their MIDI channel to "—" or Kbd on Off to "Off".

Editing Patches Through a Performance

Just as you can edit Samples through a Partial and Partials through a Patch, you can edit Patches through a Performance. From any Performance Page, open the Com menu, and select Edit Patch. You will go to a Patch-level page, and the name of the Page will be framed by *'s, indicating you are editing in Subsidiary mode.

In most ways, this page behaves just as if you went to it from the Sound menu. You are not restricted to using Patches that are part of the current Performance — you can access any Patch currently in RAM. You can edit and even save the Patches as you listen, and you can move down to

the Partial and Sample edit levels as well.

All keyboard ranges and fades that you have created in the current Performance will be in effect as you play each Part.

Split Numbers

The DJ-70 will respond in Omni mode if the Select/MIDI in parameter is set to Omni On(**). When you change that Parameter to a Part number, however, the Patch will change too, in accordance with the assignments in the Performance. That makes the Select/MIDI in parameter act like a “Solo” switch on a mixing console: when you are playing a multichannel sequence, it allows you to choose which part you are hearing, with the correct Patch. It goes one better than simply soloing the MIDI channel: it will also isolate Parts that share the same MIDI channel.

For example, if Piano L and Piano R are two Patches in a Performance both set to MIDI channel 1, you cannot listen to them individually at the Performance level without changing one of their MIDI channels. On this page, however, you can, by changing the Select/MIDI in parameter.

In you change the Patch, on the other hand, the Part number will not follow. This lets you quickly audition different sounds in a given Part. However, any change you make in the Patch parameter will not be reflected in the Performance when you Exit the Patch page. If you want to make the change permanent, you will have to enter it again on the Performance page.

The Part Map

There’s another way to edit Patches from within a Performance. Go back to the Play page pressing the Play button. Look at the fifth Function key Page, P.Map.

This is the Part Map. Like the Partial Map at the Patch level, the Part Map provides a way to edit Patch parameters from another dimension. The Parameter line lets you select which Parameter of the various Patches in the current Performance you want to look at, and it displays the settings for that Parameter in the Patches assigned to all 32 Splits simultaneously. For example, if you set it to Panning, it will show you the Pan position for all of the 32 Patches in the Performance. There are 35 Parameters available, which cover the Patch Common and Patch Ctrl pages (you can’t edit the MIDI Splits from here).

When the cursor is on an individual Split number the Parameter next to the Part number highlights, and you can change it using the S1 or S2 buttons or VALUE wheel. You cannot change a Parameter for a Split with no assigned Patch.

This page is useful for comparing Patches in a global context, for balancing levels, and for spotting anomalies or conflicts between Patches. If, for example, you inadvertently set two different Patches to the same MIDI Program Number, it will show up clearly here. So will a Bender setting radically different from all of the others.

Any changes you make on this page will be reflected when you go to a Patch page and look at the corresponding parameter.

Other Performance Functions

Initializing a Performance

If you want to start working on a Performance from scratch, you can either select an empty Performance (with 64 to choose from in RAM at any time, it's usually not hard to find one); you can choose Blank from the Select window; or you can use the Initialize function on the current Performance.

This is chosen from the Com menu on any of the Edit Performance pages (but not the Play pages). Select Initialize and a window will open asking "Are You Sure?". If you're sure, select Execute; if not, press the "Exit" button. When you initialize a Performance, all of the Parts are turned Off, and all other Parameters return to their default settings.

Copy and Delete

The Copy and Delete functions on the Performance Com menu work the same way as their counterparts on the Patch and Partial Pages. Copy lets you create a copy of the currently selected Performance in another Performance slot, so that you can edit it without disturbing the original. The new Performance gets an "AA" suffix, and subsequent copies of the same Performance get "AB", "AC", etc.

Delete removes a Performance and its subsidiary files from RAM (but not from disk), to give you more room to move around in. You can hear each Performance in the window if you pass the cursor over its name without confirming.

Files at the bottom of the list will be deleted faster than those at the top.

This window has an extra feature at the Performance level, which clears RAM out completely. Select Volume switch at the bottom of the window, and the DJ-70 will revert to an unloaded state. You get a warning box before the operation actually executes. You can always clear RAM by loading something into it and selecting the Internal Memory-clearing feature, but with this function you can have a completely empty memory in one operation. (We used this feature back in Chapter 1.)

MIDI Program Changes

The Patch Map

The DJ-70 is capable of dealing with MIDI Program Changes in a number of ways. As we've seen, each Patch is assigned a Program Change number. You can view the numbers for all of the Patches in a Performance using the Part Map (P.Map), or you can go further than that and view the numbers for all of the Patches in RAM. This is the Patch MIDI Map: from the Perform menu, select MIDI, and then Page 3, PtchMap.

This is another good way to check for Program Change conflicts. You can change the Program Change (“Prog#”) assignment for any Patch on the list by moving the cursor to the Patch’s name, and then pressing the S1 or S2 button or turning the VALUE wheel to lower or raise the Program Change number. You can set Prog# anywhere from 1 to 128. Any changes made here to a Patch’s Program Change assignment will show up on the Edit Patch Common page when you go back to it and will be saved when you save the Patch.

The Patch Map is a dynamic construct — which is a fancy way of saying that it isn’t saved anywhere as a single “thing”, but rather is constructed by the operating system on the fly, from the Patches that are currently in RAM. You can’t save a Patch Map by itself — it is “saved” when the Patches are saved.

Patch Conflicts and Sustained Notes

If you happen to give two Patches the same Prog#, then when that Program Change is received the Patch with the lower number on the Patch Map will be the one called.

If a note is being sustained and the channel it’s on receives a Program Change, the note will continue as if nothing had happened, until the key (or if the Sustain Pedal is being held, the pedal) is released. The next note to be played on the channel — whether the previous note has actually stopped or not — will sound the new Patch.

When playing a Performance, all slots in the Patch Map are active at all times. This means that if the DJ-70 receives a Program Change that is mapped to an empty slot on the Map (that is, a slot with a Prog# but no Patch), it will call up an empty Patch for the Part assigned to that MIDI channel, and that channel will now make no sound. (Empty slots in the Patch Map are assigned a Prog# that is the same as the slot number.) If, however, the DJ-70 receives a Program Change that is not mapped to any slot, the Patch will not change. This situation could arise if, for example, Patch No. 1 was set to Prog# 13, and no other Patch had been set to Prog# 1.

The Performance Map and Basic Channel

MIDI Program Changes can also be used to change Performances, so you can instantaneously change the entire character of the DJ-70. This is set up on the Performance Map page, but before we look at that, we need to discuss the Basic Channel parameter.

While Patches can be changed from MIDI on any channel that is active in the current Performance, to change a Performance over MIDI, the command must be sent on the DJ-70’s Basic Channel. Setting this up requires going to a totally different section of the DJ-70’s software. Press the SYSTEM button. From this Menu select MIDI. Then go to Page1, Config, which is short for “Configure”.

Set the Basic Channel to the channel you want to use to change Performances. (This channel is also the channel that the DJ-70 accepts System Exclusive data on, or but we’ll deal with that in Chapter 9.) It is very strongly recommended that this be set to a MIDI channel that you will not be using within any Performance to change Patches.

Assigning a Program Change number to a Performance is handled on the Performance MIDI Map, which is Page 4 of the Performance MIDI function (PfrmMap). Unlike Patches, which can be assigned Program Change numbers on several pages, this is the only place you can assign Program Changes to Performances. The procedure is the same as on the Patch Map: put the cursor on the Performance you want to set the Program Change number for, and raise or lower the Prog#. You can only use Program Numbers between 1 and 64.

If you do set the Basic Channel to a channel being used in the current Performance, either because you have run out of channels or you just like to ignore good advice, you will not be able to change Patches over MIDI on that channel. And if you should send a Program Change to that channel which is not assigned to a Performance, you will call up an empty Performance — the DJ-70 will be totally silent. Bad bummer.

The Performance Map is also a dynamic construct. Each Performance's Program Change assignment is stored when you save the Performance itself. If you have two Performances assigned the same Program Change number, the lower-numbered one on the list will take priority.

MIDI Filters

Within a Performance, selected MIDI messages can be enabled or disabled on individual channels (not Parts). This is handled on the first two pages of the Performance MIDI Function: Fil 1 and Fil 2.

Disabling the reception of unwanted MIDI data at this level can help to avoid possible processing delays within the DJ-70 when it is sent large amounts of data. For example, some MIDI keyboards generate Channel Pressure (aftertouch) at all times, and if the DJ-70 has to interpret that data constantly, even if there are no Patches in use that respond to it, its overall response to MIDI may be affected. Turning off Channel Pressure on one or more channels can prevent this from becoming a problem. This Page also determines whether a channel will respond to polyphonic aftertouch (Key Pressure), whose use is becoming increasingly common in high-end MIDI studios.

MIDI channels 1–8 are set on the Fil 1 page, and channels 9–16 are set on the Fil 2 page. To enable or disable MIDI reception of a specific type on a specific channel, move the cursor with the cursor keys to a position directly underneath the channel number you have in mind and in a line with the Parameter you want to deal with. An “O” means the data type is enabled for that channel, while a “—” means it is disabled. Press the S2 button to enable, and the S1 button to disable.

You can also enable or disable a data type on all MIDI channels simultaneously: put the cursor on the asterisk under the word All, across from the Parameter you want to adjust. Press the S1 or S2 button, and the Parameter will be set for all 16 MIDI channels (not just the eight on the current Page) at once.

The Parameters are as follows:

Prog determines whether Patches on the channel will change with incoming Program Change messages. If you are layering multiple Patches on a channel in a Performance, you may

want to disable this Parameter so that you don't accidentally make all the Patches on that channel the same. If you are using the Control Channel as a Part Channel (despite what we told you), disabling it from responding to Program Changes can help prevent confusion. This parameter does not disable the Control Channel as far as Performances and/or Volumes are concerned — that channel is always active unless you set it Off on the MIDI Config page.

Bend is Pitchbend, whether it will be recognized or ignored.

Mod is Modulation wheel, or Controller #1, whether it will be recognized or ignored.

Hold is Sustain Pedal, or Controller #64, whether it will be recognized or ignored.

A.T is aftertouch. This has three settings: Set to "C", the channel will respond to Channel Pressure (mono aftertouch), in which all notes are affected equally. Set to "P", the channel will respond to Key Pressure (polyphonic aftertouch), in which each note can be controlled individually. You should only use this setting if you have a MIDI controller or sequencer that generates Key Pressure — not many of them do. Or you can shut it off ("—"), and the channel will respond to neither.

Vol is MIDI Volume, or Controller #7. When this is shut off, the Lev parameter on the Performance Play page will not change when you send MIDI Volume to that particular channel.

P.L stands for "Phase Lock". When the DJ-70 is playing multitimbrally, its response to incoming MIDI data under some circumstances is not instantaneous. When it receives, for example, five simultaneous note-ons on five different channels, it will play the notes in sequence, starting with the one assigned to the lowest Part number, then the next highest Part number, and so on. The time interval involved is minuscule, but if there are two fast-attacking sounds in two different Parts which are supposed to start simultaneously, some "blurring" or phasing may be audible.

To prevent this, simultaneous notes on all channels that have this Parameter enabled will sound exactly at the same time. So if, for example, you had two drums on Parts assigned to channels 3 and 11, you would turn P.L on for those two channels, and they would sound precisely together.

There's a slight trade-off for this feature, which is that notes on Phase-Locked channels might be slightly delayed to achieve the lock. Therefore, you might find that sequenced tracks using this feature might have to be advanced slightly. It also means that in general, if you don't need this feature, you should leave it off.

Vel determines the velocity response curve of the channel, to compensate for the way different keyboards generate MIDI velocity data, or just to give the instrument a different "feel". Set to "—", the response is linear: what goes in, comes out. The seven available curves are illustrated below. Note that they are quite different, and completely independent, from the velocity curves in the Partial TVA and TVF.

The MIDI Filter settings are applied only to the current Performance, and are saved with the Performance. When you change Performances, the filters will change.

Volumes

We've been referring to Volumes in this and previous chapters, so now it's time to look at them in detail.

A Volume is a set of files, grouped together for convenience of storage and manipulation. It can be as small as a single Sample, or as large as several dozen Performances, each with its own Patches, Partial, and Samples. In actual practice, Volumes are usually quite large, so that a single Load or Save operation can handle a complete DJ-70 setup, containing perhaps hundreds of individual files, in one shot.

The entire contents of RAM comprise a single Volume. Even though you can load a Volume and then additional Volumes without clearing the first Volume from memory, the result is still considered to be a single Volume. We'll see how this works in a bit.

Loading Volumes

Like any other file, you load a Volume from floppy disk on the Disk Load page, setting Target to Volume. The Page provides you with the total length of the Volume, so you can determine whether it will fit into RAM. As usual, you are given a choice as to whether you wish to clear Internal memory and just have this Volume in RAM, or to add it to whatever's already in there.

After a Volume is loaded, any other file, from Sample to Volume, can be loaded subsequently, and as long as you don't clear Internal memory, the newly-loaded file will be combined with the current contents of RAM into the current Volume. If you are combining Volumes in this way, it's a good idea to watch extra carefully for Program Change conflicts among the various Patches and Performances you are loading in.

Naming Volumes

The name of the current Volume is shown on the Performance Common page from the Performance Edit function. Note that if you have loaded in more than one Volume, the name of the current Volume will be that of the most recent Volume loaded. You can change the name of the Volume using the Name box.

Cleaning Files from Volumes

Like any other file, a Volume is not permanently stored until it is saved to disk. Unlike other files, however, which only save themselves and their direct subsidiaries when they go to disk, when you save a Volume, everything in RAM gets saved, whether or not it is actually used anywhere. Samples that never made it into Partial, or Partial not assigned to any Patch, get saved along with everything else. Therefore it's important before saving a Volume to find any extraneous files that will take up disk space, and Delete them from RAM.

Be sure, however, not to delete any files that you'll need, even if they are on disk already.

If a file is not part of the Volume in RAM when you save it, then the next time you load the Volume, the file will not be loaded.

Saving Volumes

Volumes are saved to disk, not surprisingly, on the Disk Save page. Select Target to be Volume. The Lcd tells you the length of the current Volume and the amount of space available on the current Drive.

Program Changes

Deleting Volumes

Deleting a Volume from RAM is the same as emptying RAM. You can do this by turning off the DJ-70 and turning it back on again (not recommended), by loading in a new file at any level and telling the DJ-70 to clear Internal memory, or by opening the Com menu from any Performance page (Edit or Play), selecting Delete, and then clicking on the Volume switch at the bottom of the window that opens. This operation resets also the automatic numbering used for Performance, Patch, Partial and Sample automatic naming function.

Chapter 9: System Functions

The System Functions, most of which are accessed from the System menu, contain controls and parameters of the DJ-70 that are not directly sound-related. The tasks they cover include setting up input and output devices and configuring the basic operating parameters of the software. Many of these functions have been touched on in earlier chapters.

The System menu is opened by pressing the SYSTEM button on the front panel. System Pages can also be accessed through a number of topics and subtopics in the Index, or through a Jump page.

System Parameters

Master Tune allows the entire DJ-70 to be tuned up or down to match other instruments in an ensemble or on a recording. The range is about 50 cents, or a quarter-tone in each direction.

Cue Mode allows you to decide if using the CUE button you hear in the headphone only the **Single** Cueing sound or **All** the program.

Monitor On/Off allows you to enable or disable the thru of the input signal at the L/R output.

Disk Tools

Opening Disk Tools from the System Menu is just another way of getting to most of the Disk Pages we have already examined in Chapter 3. You can also get to them through the Index ("Disk"). We'll provide brief summaries of them here. There are, however, a few topics that have not yet been covered, and these are discussed here in detail.

Load

The Load page lets you select a file, at any level, from a disk, and move it into RAM for editing and playing. Select the Target (the file level) and the specific file, using the cursor keys.

System PRM		Ext
Master Tune (cent)		1
Cue Mode	All	
Monitor		On

Scroll the Lcd Display using the Up/Down switches the top switch scrolls the Lcd Display by one entry, and the bottom switch by 10. The Lcd Display shows the size of every file (in seconds, referenced to 44.1 kHz sampling rate), which will help you determine whether you need to clear Internal Memory before you load it (compare it with the “Internal Free” parameter at the bottom of the Lcd Display). If you attempt to load in a file which is too big for the available RAM, you will get an error message.

You can also load in files from a Roland S-550, S-330, or W-30 floppy disk(s). This is a special function, Convert Load, which is described at the end of this section. (If you try to load a file in one of these formats on this page you will get a communication error.)

In addition, you can load just the Parameters of a Partial, Patch, or Performance, without its attendant Samples (set Target to one of the “PRM” levels), so you can easily use those as templates for Samples already in memory, or for other Samples on disk not associated with the higher-level files.

You can also Load, selecting “Song” or “Volume + Song” as Target, the RPS song of the sequencer.

Save

The Save page lets you select any file currently in RAM and write it to the floppy disk. Select the target level, and file using the cursor keys, and scroll the Lcd Display using the Up/Down switches. You can only save one file (of any type) to a floppy disk. If the file is too big to fit on a single floppy, you will be told how many floppies you will require, and then as each one is filled, you will be prompted to insert the next one.

Util

The Disk Utility (Util) page contains two operations for formatting floppy disks and saving the Operating System on floppy disk.

FD Format

This formats the floppy disk in the drive. When you save a file to an unformatted floppy, the DJ-70 automatically formats the disk first, so this operation is not essential. It is helpful, however, if you know you are going to be doing a lot of floppy-saving during a session, because you can save some time by pre-formatting a supply of floppies before you start.

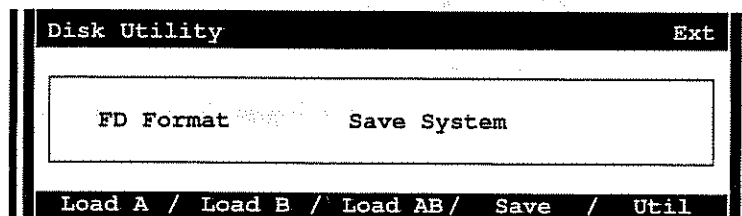

Save System

This function records the operating system software and several system parameters onto the floppy disk drive. It has a number of uses:

- Installing a new or upgraded version of the DJ-70 operating system onto the DJ-70.
- Storing a copy of the operating system with modified Jump Menu settings onto a floppy disk for next boot. Note that saving the system on a floppy will erase any sound files on it.

The following parameters are stored with the operating system when you select SaveSys, and will therefore be recalled the next time you boot the DJ-70 with this disk:

- the two sets of Jump pages
- the 10 User Set templates from the Partial function
- the Type and Trigger parameters on the Sampling page, as well as whether sampling is done at full- or half-speed.

In addition, whichever Pages were last opened at the Performance, Patch, Partial, and Sample levels are memorized when you execute SaveSys. Here's an example of what this means:

Let's say that the last time you were in the Edit Sample function before you executed this SaveSys, you happened to be on the Truncate page. Also, the last time you were in the Edit Partial function, you were on the TVF page.

Okay, execute the SaveSys. Now turn off the DJ-70 and turn it back on again with this disk inside the floppy disk drive. When you select Edit Sample from the Sound menu, it will automatically open to the Truncate page, and when you select Edit Partial from the Sound menu, it will open to the TVF page. If you didn't access a particular Function during the current session with the DJ-70, these "Page defaults" will remain unchanged from the previous session.

This is mostly a matter of convenience, and you should try to set the Function pages up so that the ones you will be using first in a typical session are the ones that open first.

Using Disks from Other Samplers (Option/Convert Load)

If you have any disks containing sounds created with a Roland S-550 or S-330 Digital Sampler or W-30 Music Workstation, you can load them into the DJ-70's Internal Memory. Their data formats, however, are quite different from the DJ-70's, and so a special operation is needed to load them. This operation is called Convert Load. If you try to load such files from the Disk Load page, you will get a communications error. (For purposes of this discussion, let's assume the files have come from an S-550.)

From the System Menu, select Convert Load.

The Target parameter determines which files on the disk will be loaded. "**All**" means everything on the disk. "**Patch to Patch**" means S-550 "Patches" will become DJ-70 Patches. "**Tone to Partial**" means S-550 Tones will become DJ-70 Partials.

If you insert a floppy that is not in the S-550 format, you will get a message telling you so.

When you insert a valid floppy disk, the system takes a few seconds to verify and catalogue the disk, and asks you, in polite light letters, to “Please Wait”.

The names of all files at the Target level you have chosen will then appear in the window. If there are more file names than the window can display, you can scroll the list with the Up/Down arrow box. The numbering may look a little strange, because these samplers use an octal system: the first item is “11”, the ninth is “21”, etc. If the Target level is All, then “Convert All Execute” will be the only text showing.

Select the file you want to load and confirm pressing S1 or S2. As with any other disk Load operation, you will first be asked if you want to clear the Internal Memory (if there is anything currently in it).

You will then see the words “Now Working”, and the name of each file and subsidiary file in the window as it loads. At the same time, the Internal Free parameter will decrease as the sounds go into RAM. If there is not enough space in RAM for a particular file, an error message “Wave Memory Full” will appear, but the operation will continue. When the operation is finished, the Lcd Display goes back to its previous state. Press the “Exit” button to get back to the System menu.

You can now work with these sounds just like any other sound created in the DJ-70, editing them, playing them, and saving them to disk. (If you have loaded in a Patch, all of the subsidiary Samples and Partials have been loaded as well.) The names will be slightly modified versions of the names as they appear on the Convert Load Lcd Display. In addition, Patch names will end with a “/”. If an S-550 Patch is made up of two Tones, then it will be converted into two DJ-70 patches. The name of the first DJ-70 Patch will end with “/”, and the name of the second Patch will end with “\”. (You can recombine them in a Performance.)

Since the analog sections of the S-550, S-330, and W-30 are somewhat different from the DJ-70's, you may find that the files do not sound exactly the same, but will require a bit of tweaking to get them just right. On the Edit Sample Loop page, the sampling rate for these Samples is displayed as 30 kHz. Although the DJ-70 cannot record a Sample at 30 kHz, it has no trouble playing back one recorded at that rate.

Note that these sounds have been loaded into RAM, and are not stored on disk until you execute a Save.

Convert Load is a very specific operation — it only loads. You cannot Save DJ-70 sounds in S-550/S-330/W-30 format, nor can you load sounds from an S-50 disk. However, if you have S-50 disks, you can use an S-550, S-330, or W-30 to convert those sounds to its format, and then Convert Load them into the DJ-70.

Load While Playing

The Load While Playing function allows the user to easily load some sounds without stopping the performance playing.

The DJ-70 can be divided into two memory zones =(A and B) , each zone can be dimensioned (in 1/10 second steps) by the user and can be loaded separately using the Load A or Load B options in

the Disk Load Page.

The Parameters of the zone Size (A: XX.X - B: XX.X) sec are located in the Play Page and in the Disk Load Page. Modifying one of these parameters also the other is automatically set according to the total memory size of the DJ-70.

The setting of the zones size is currently named "WALL".

Modifying the "WALL" in the play page, the parameters "Mem", indicating the position of each patch in the memory area (A, B, A/B), change according with the new "WALL" position.

In the Disk Load page there is a field called "INFO". Pressing a key on the keyboard, the "INFO" field indicate the patch name associated to the key and the memory zone in which it is located.

The position of the patch in the memory is very important when loading separately the "A" zone or the "B" zone.

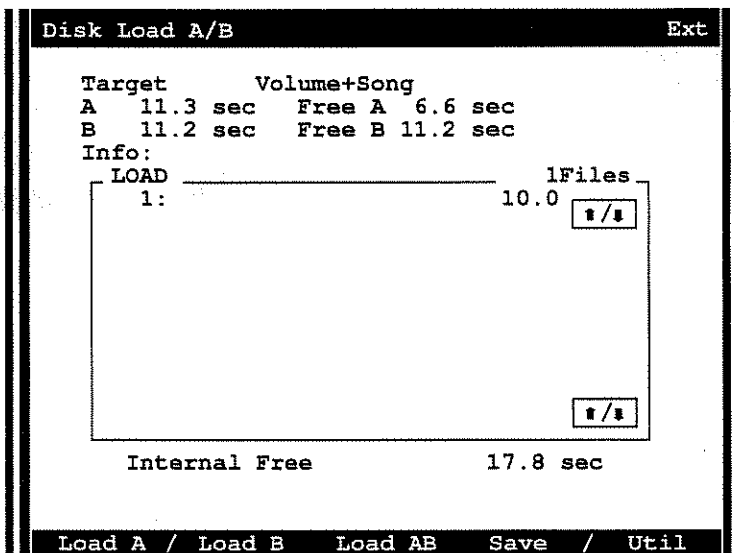

Loading the "B" zone, all the samples in the "B" zone and those across the "A" and "B" zone (A/B) are deleted.

If some patch containing samples located in the "B" memory zone are playing, they are stopped and deleted but all the patch containing samples located in the "A" zone can continue to play.

The wall position is automatically saved / or loaded in a disk when saving or loading a Volume. This feature is very useful for Live performance because you can play continuously using the patch containing the samples located in one memory zone, while loading the other memory zone.

RPS Sequencer

The DJ-70 is equipped with an 8 track sequencer with RPS Function.

This sequencer is very easy to use, it is very similar to a tape deck.

The RPS function allows the user to assign the Start/Stop of each track to any key of the keyboard. This is very useful to save memory because you can create a long sequence using small samples and then assign the Start of this sequence to one key of the keyboard using this sequence just like a long sample.

How to Record a Track

Press the RPS button, the RPS master display will be shown. Press the Rec button, the Led will be lit. In the REC column there is an arrow indicating the track we are going to record.

Move the cursor to the track that you want to record and press the F5 function key button. The arrow will move to the new track to record.

Either press the Start/Stop button or press any key on the keyboard, the Start Led will be lit to indicate that the sequencer is recording.

At the end of the recording session press again the Start/Stop button, the Led goes off. A little dot is shown at the left of the arrow indicating that the track has been recorded.

Realtime Phrase Sequencer						ComExt
Rps	On	Rec KeyOn	On			
Perf	1	Stop By	C_5 (72)			
Type	Play ass	Sh	Mode	Out	Rec	
1 Trk	Strt/Stp	0	1Shot	Kbd	•	
2 Trk	Strt/Stp	0	1Shot	Kbd	•	
3 Trk	Strt/Stp	0	1Shot	Kbd		
4 Trk	Strt/Stp	0	1Shot	Kbd		
5 Trk	Strt/Stp	0	1Shot	Kbd		
6 Trk	Strt/Stp	0	1Shot	Kbd		
7 Trk	Strt/Stp	0	1Shot	Kbd		
8 Trk	Strt/Stp	0	1Shot	Kbd		
On/Off /						Erace / Rec On

How to Play a Recorded Track

Press the Start/Stop button and all the recorded tracks assigned to Start/Stop will start to play.

How to Erase a Recorded Track

Put the cursor over any field of the track to be erased, press the F4 function key, the little dark point indicating the recorded status will be deleted.

For each track there are different parameters:

Track type : This parameter must be set before recording the track and then cannot be changed. The track type can be "TRK" or "CMD".

The track identified as "TRK" can contain only notes that triggers samples, the track identified as "CMD" can contain notes triggering samples and notes triggering "TRK" tracks whose Start/Stop is assigned to a keyboard key.

Only one track can be assigned as "CMD"

Play Assign : The default for this parameter is set to "Start/Stop", it indicate how the track can be started. You can set this parameter to Start/Stop, indicating that the track will start pressing the Start/Stop button, or to any keyboard key number means that pressing that key the track will start to play.

Shift: This parameter shifts the track by a specified number of semitones.

Mode: It indicates the read mode of the track; it can be set to: 1Shot, Loop, Quick -1Shot , Quick-Loop.

1Shot = The track will start from the beginning , including pauses, when a key on message is received, and will stop at the end also if a key off message is received before the track's end.

Loop = The track will start from the beginning, including pauses, when a key on message is received, at the end the track will start again from the beginning.

If a key off message is received the track will stop.

Quick1= The track will start from the first event without playing possible pauses recorded before the first event. It will stop at the end also if a key off message is received before its end.

Quick L= The track will start from the first event without playing possible pauses recorded before the first event. at the end, the track will start again from the first event. If a key off message is received the track will stop.

RPS On/Off : This parameter indicates the activation state of the RPS function (On/Off).

Rec Keyon : If set in "ON", this parameter allows the recording start simply pressing a key on the keyboard.

Perf: The number of the performance recalled at the sequencer Start.

Stop By : This parameter is used to set the key number used to stop the tracks started by a keyboard key.

Out : Each track output can be assigned to KBD or Part 1 - 31.

Assigning the track out to "KBD", all the note messages contained in the track will be sent to the various split according with the Split ranges specified in the Play Page. If Assigned to any of the parts, the note messages of the track are sent to the specified part.

MIDI

Most of the MIDI functions of the DJ-70, as we have seen, are set on the Performance, Patch, and Partial editing pages. A few others are accessible through the System menu, by selecting MIDI. MIDI Sample Dumps are discussed in detail in the next chapter.

Config

The Config page, which was discussed briefly in the previous chapter, contains eight parameters. System Exclusive determines whether the DJ-70 will respond to System Exclusive messages from a MIDI device, such as a computer editor or another DJ-70. The DJ-70 responds to two types of System Exclusive messages: Roland System Exclusive and Universal System Exclusive.

Roland System Exclusive messages can be used to control almost every Parameter in the DJ-70, and a complete chart appears in the Appendix of this manual. The Universal System Exclusive messages that the DJ-70 responds to are MIDI Sample Dump Standard commands.

MIDI Config	Ext
System Exclusive	Off
Unit Number	31
Basic Channel	1
Scratch Rx/Tx	On
Pitch Bender Rx/Tx	On
Modulation Rx/Tx	On
Sustain Rx/Tx	On
Program change Rx/Tx	On
Config / Dump / / /	

See Chapter 9 and the Appendix for more details.

The Unit Number and the Basic Channel work together to allow an individual DJ-70 to have a specific “address” when it receives System Exclusive messages, so that different DJ-70s in a system can be controlled individually from a common source, such as a computer.

The Basic Channel also determines (as we discussed in the previous chapter) in which channel the DJ-70 will call up Performances from RAM

If Basic Channel is set to a number from 1–16, Program Change commands on that channel number will call up Performances, and MIDI Sample Dumps can take place on that channel.

(Some editing programs and samplers refer to the channel number as the “Device ID”, for purposes of exchanging Sample Dump information.)

Roland System Exclusive messages are responded to regardless of the Basic Channel setting. If Control Channel is set to 1–16, and Unit Number is also set to 1–16, then the Unit Number will be ignored, and the Device ID will be the same as the Control Channel. If, on the other hand, the Unit Number is set to 17–32, the Device ID will be the Unit Number.

This chart shows how the Parameters on this Page interact.

System Exclusive On/Off

Enable or disable the Tx and the RX of the SysExe messages.

Unit Number

The Unit number and the Basic Channel work together to allow each individual DJ70 to have a specific address when it receives a SysExe message.

Basic MIDI Channel

This is the channel used to receive the Performance Program Change messages. The Pitch bender and Modulation messages are transmitted on this channel. The notes received on this channel are filtered through the performance limits to be sent to the right split.

Scratch RX/TX On/Off

Enable or disable the TX/RX of the Midi messages reserved for the scratch effect.

Pitch Bender RX/TX On/Off

Enable or disable the TX/RX of the Pitch Bender on the Basic MIDI Channel.

Modulation RX/TX On/Off

Enable or disable the TX/RX of the Modulation on the Basic MIDI Channel.

Sustain RX/TX On/Off

Enable or disable the TX/RX of the Sustain on the Basic MIDI Channel.

Program Change RX/TX On/Off

Enable or disable the TX/RX of the Program Change on the Basic MIDI Channel.

Dump

This page is where you initiate a MIDI Sample Dump, if it needs to be done from the DJ-70. It will be explained in detail in the next chapter.

Briefly, the Unit Number and Control Channel parameters are the same as on the Config page. The Source parameter chooses a Sample from RAM to transmit out the MIDI OUT jack on the rear panel in MIDI Sample Dump Standard format. The Execute switch initiates the transmission. This function is not necessary in most cases when using a computer sample editor, but it can be used to send a Sample from one DJ-70 to another over MIDI.

Chapter 10: Data Transfer and Storage

The DJ-70 allows data to be transferred in digital form using the MIDI Sample Dump.

MIDI Sample Dump

The DJ-70 supports the MIDI Sample Dump Standard, and can transfer sample data over MIDI to another device which also supports the standard. This can be another sampler, another DJ-70, or a computer equipped with sample-editing software. Samples are transferred to and from Internal Memory, not disk.

Only a single Sample can be transferred at a time. Stereo Samples must be transferred as two separate mono Samples. The Sample Dump Standard contains information about sample rate, length, and number of bits per individual sample. When setting up a program or sampler to send data to the DJ-70. When receiving data from the DJ-70, make sure its sampling rate is the same as the DJ-70 Sample being sent. The DJ-70 is a 16-bit machine, and all transfers should be done in that format.

The Sample Dump Standard also contains information about loop start and stop points, although not the "loop mode". Originally, the Standard only supported a single loop in each sample, but a recent extension to it allows for multiple loops. Some programs and samplers don't yet recognize this extension, however, and if a DJ-70 sample with a Release loop is sent to one of these, the Release loop data will be ignored.

The Sample Dump Standard uses MIDI channel information, so make sure that the receiving device and the transmitting device are set to the same channel (or "Device ID"). When you are transferring a Sample from one DJ-70 to another, make sure both the Unit Numbers and the Control Channels for the two units are the same.

Closed-loop Transfers

MIDI Sample Dumps work best in a "closed-loop" setup, that is, one in which MIDI cables run in both directions, from the MIDI Out of the DJ-70 to the MIDI In of the computer or other sampler, and from the MIDI Out of the other device to the MIDI In of the DJ-70. When wired this way, the Standard can automate the transfer process to a great degree, using commands for dump requests, acknowledgements, cancelling, and other operational aspects.

For example, to download a sample into a typical sample editor, all you have to do is tell the editor the number of the sample you want to work on (which the DJ-70 interprets as its “slot” number in RAM), and then tell it to get it. The software requests the DJ-70 to send its sample data, and the rest of the operation is automatic.

Sample Dumps can be requested while the DJ-70 is on almost any Page. The exceptions are the Disk pages (regardless of whether they are accessed through the Com or System menus), and the Sampling page. If you request a Sample number for which there is no Sample in RAM, you will get an error message.

Similarly, Samples can be sent to the DJ-70 on most pages. When a Sample is sent, it has a number attached to it, which the DJ-70 will interpret as a RAM slot number. If there is another Sample already in that slot, it will be erased and replaced with the new one. Make sure when sending a Sample to the DJ-70 that there is enough free RAM (check the Remaining parameter) to accept it all.

Open-loop Transfers

Under some circumstances, the Sample Dump procedure isn't quite so well automated. This is true when an “open-loop” configuration is being used (only one MIDI cable is connected, from the MIDI Out of the dump-er to the MIDI In of the dump-ed), or when the device receiving the dump does not have a “Request” function (such as when transferring from one DJ-70 to another). In these cases, the receiving device must be told that a Sample is coming its way.

To send a Sample from the DJ-70, you must initiate the Sample Dump by going to the Dump page (choose MIDI from the System menu). Select the Sample you wish to send with the Source parameter, and then select Execute. The software will pause briefly to wait for an acknowledgement from the receiving device, and will then proceed with the dump regardless of whether it gets one.

Chapter 11: Upgrades and Service

System Software

Because the operating system of the DJ-70 is entirely software based, it can be easily changed and upgraded. These upgrades will be distributed on floppy disks, and you can then use these disks to boot the DJ-70.

When you receive a new system-software disk, insert it into the floppy-disk drive before turning on the power to the DJ-70. This is the exception to the rule, stated previously, that you not boot with a floppy in the drive.

When you turn on the unit, it will load the system software from the floppy disk instead from ROM.

Adding Memory

The DJ-70 comes equipped with two Megabytes of RAM. Two additional Megabytes can be added, for a total of 4 Megabytes. RAM upgrades use standard 1-megabyte Single In-line Memory Modules (SIMMs). However, be sure to use only SIMMs that are rated with a speed of 100 nanoseconds (ns) or faster (i.e., a lower number), and purchase them only from a reputable dealer.

Adding the SIMMs is relatively simple and can be done by the user. However, if you are not experienced with disassembling and reassembling electronic gear, it is strongly suggested you ask your dealer or a qualified technician to do the job. Make sure all connections, especially the AC cord, are removed from the DJ-70 before opening the case.

Cleaning and Maintenance

As far as maintenance is concerned, the DJ-70 should require a minimum of attention. Keep dust away from the unit, especially the floppy disk drive. Use a paint brush or a soft cloth, either dry or very slightly dampened with water. If serious dirt or grime accumulates, use a mild detergent, and afterwards make sure to wipe it clean with a dry cloth. Never use benzene, alcohol, turpentine, or any chemical solvents.

Returning for Service

Except for the memory SIMMs, the DJ-70 has no user-serviceable parts. Attempts by unauthorized personnel to repair or modify the DJ-70 will void the warranty and are generally considered not smart. If you have trouble with the unit, you must bring or send it to an authorized Roland repair facility. Consult your dealer before sending it anywhere.

Use the original packing material that came with the DJ-70 to ship the unit. If the original packing material is not available, use a reinforced, sealable, foam-lined case.

Troubleshooting: Why Won't It...

I am sampling a Mono source, but nothing seems to be coming in.

When the Mode parameter is set to Mono, only the left input is recognized. Make sure your input cable is connected to the L(MONO) input, and not the R input.

I call up a Patch to play from disk, but there's no sound.

If there are Samples or other subsidiary files shared by two or more higher-level files on a disk, and you delete one of those high-level files, the Samples will be erased as well. Then when you try to load one of the other higher-level files in, the deleted Samples cannot be found, and will not be loaded.

I'm working on adjusting the Release loop of a Sample, but I can't hear what I'm doing. Or, I've constructed a Release loop, but when I play the Partial it's in, I don't hear it.

You can only hear the Release loop from the Loop page (or any of the Edit Sample pages) if the KeyOn Mode parameter is set to "R-Loop". Any other setting, and the Release loop will not sound.

When you get up to the Partial level, remember the Release loop will only start to play after the key is released (hence the name). Therefore, for it to be audible, and not cut off by the TVA envelope as soon as the key is released, the envelope must have a relatively long release time (Time 4).

I've created a new Sample and loaded it into a Partial, but now when I move up to Patch level and load the Partial in, I don't hear anything.

Just selecting a Partial to go into the Partial parameter on the Edit Patch Split page does not automatically enter it — it has to be deliberately assigned to a Split first. An easy way to do this is after selecting the Partial, simply click on Set. This will assign the Partial to the entire keyboard range (assuming you have not changed the Upper and Lower parameters) in the Patch.

However, there's an easier way to do this and that is to record the Sample in Subsidiary mode coming from the Patch level. This automatically creates a new Partial and a new Patch, and assigns the Partial to the Patch automatically.

Specifications

Digital “DJ” sampling workstation, RPS sequencer, 37 note dynamic keyboard, Scratch Dial, 24-note polyphony, 3.5” floppy disk drive(2HD/2DD) for sample sequence and global parameters, Load While Playing Function, Large back-lit LCD Graphic Display.

Input/Output

Input Level

+4 dBm ~ 50 dBm (variable)

Input Impedance

10 k Ω , unbalanced

Output Levels

Stereo Out: +7 dBm (1 voice)

+19 dBm (16 voices)

Output Impedance

Unbalanced 200 Ω

General

Maximum Polyphony: 24 Voices

Sampling Frequency:

44.1kHz, 22.05kHz

Convertors

Analog-to-Digital: 16-bit linear

Digital-to-Analog: 20-bit linear

Frequency Response: 20 Hz – 20 kHz

(+0 / -3dB)

Signal-to-Noise Ratio (IHF-A type)

Stereo Out: >80dB (all volumes: Max)

Dynamic Range: >87 dB (1 voice at rated output)

Total Harmonic Distortion: <0.01% (A/D/A)

Sound Memory: 2Mbyte (expandable to 4 Mbyte)

Disk Drive: 3.5” Floppy (2HD/2DD)

Display: LCD: 64 X 240 dot

Front Panel master controls

Sampling Level Controls (L, R), Master Volume Control, Pitch Bender/Modulation-Fader lever, Octave (Down, Up), Jump Menu, Shift Function Key (S), Exit, Graphic, Cursor keys (Up, Down, Left, Right), Execute S1 (-), S2(+), 8 sample play pads, (Scratch), Hold, Performance, Sound, System, Play, Index, Mark, Command, Disk, RPS, Rec (Record), Start/Stop, Sample, Start/End, Cue, Back-lit LCD Graphic Display, Alpha Dial.

RPS Sequencer

8 Track sequencer with RPS function

Sample Controls

Start/End, Sample Play pads (8), Hold, Sens Peak LEDs (L,R).

Scratch simulation

Scratch Dial, Scratch pad

Rear Panel

Sampler inputs (L/Mono, R), Line Out, (L/Mono, R), Sens control (Sensitivity), MIDI Socket (IN, OUT, THRU), Sustain Switch, LCD Contrast Control, AC Socket, Power switch.

Side Panel

Phones, Phones Volume.

MIDI Implementation

Model: DJ-70

Date: May 1992

Version 1.00

1. RECOGNIZED RECEIVE DATA

■ Channel Voice Message

● Note Off

Status	Second	Third
8nH	kkH	vvH
9nH	kkH	00H

n = MIDI Channel : 0H - FH (0 - 15) 0=ch.1 15=ch.16
 kk = Note Number : 15H-6CH (21 - 108)
 vv = Velocity : ignored

● Note On

Status	Second	Third
9nH	kkH	vvH

n = MIDI Channel : 0H - FH (0 - 15) 0=ch.1 15=ch.16
 kk = Note Number : 15H-6CH (21 - 108)
 vv = Velocity : 01H - 7FH (1 - 127)

● Polyphonic Key Pressure

Status	Second	Third
AnH	kkH	vvH

n = MIDI Channel : 0H - FH (0 - 15) 0=ch.1 15=ch.16
 kk = Note Number : 15H-6CH (21 - 108)
 vv = Value : 00H - 7FH (0 - 127)

* Received when MIDI aftertouch function is ON in POLY mode.

● Channel Pressure

Status	Second
DnH	vvH

n = MIDI Channel : 0H - FH (0 - 15) 0=ch.1 15=ch.16
 vv = Value : 00H - 7FH (0 - 127)

* Received when MIDI aftertouch function is ON in CH mode.

● Control Change

○ Modulation

Status	Second	Third
BnH	01H	vvH

n = MIDI Channel : 0H - FH (0 - 15) 0=ch.1 15=ch.16
 vv = Modulation Depth : 00H - 7FH (0 - 127)

* Received when MIDI modulation function is ON.

○ Breath

Status	Second	Third
BnH	02H	vvH

n = MIDI Channel : 0H - FH (0 - 15) 0=ch.1 15=ch.16
 vv = Breath : 00H - 7FH (0 - 127)

* Received when MIDI controller select is at breath.

○ Main Volume

Status	Second	Third
BnH	07H	vvH

n = MIDI Channel : 0H - FH (0 - 15) 0=ch.1 15=ch.16
 vv = Main Volume : 00H - 7FH (0 - 127)

* Can control the volume of part corresponding to MIDI channel of received message.

* Received when MIDI main volume function is ON.

○ Hold 1

Status	Second	Third
BnH	40H	vvH

n = MIDI Channel : 0H - FH (0 - 15) 0=ch.1 15=ch.16
 vv = Control Value : 00H - 7FH (0 - 127) 0 - 63 = OFF
 64 - 127 = ON

* Received when MIDI hold function is ON.

○ RPN MSB,LSB

Status	Second	Third
BnH	65H	mmH
BnH	64H	llH

n = MIDI Channel : 0H - FH (0 - 15) 0=ch.1 15=ch.16
 mm = Upper byte of the parameter No. specified by the RPN.
 ll = Lower byte of the parameter No. specified by the RPN.

○ Data Entry

Status	Second	Third
BnH	06H	mmH
BnH	26H	llH

n = MIDI Channel : 0H - FH (0 - 15) 0=ch.1 15=ch.16
 mm = Upper byte of the parameter data specified by the RPN.
 ll = Lower byte of the parameter data specified by the RPN.

*** RPN ***

Control change is provided with RPN (Registered Parameter Number) which is a message registered to the MIDI standard for use with MIDI world. By using RPN, parameters in a MIDI unit can be changed. In practice, specify the parameter to controlled, using RPN MSB and LSB and then set the parameter value using data entry.

DJ-70 will recognize such RPNs as Pitch Bend Sensitivity and Master Fine Tune.

1) Pitch Bend Sensitivity

Can be used to set the pitch bend sensitivity of each patch set in the 32 parts of performance. When transmitting, set the MIDI channel to that of each patch.

RPN	Data entry
MSB LSB	MSB LSB
00H 00H	mmH llH

mm = 0 - 48

Can be used to bend up to 4 octaves in one and semitone steps.

The value is common to Bender Range up and down.

ll = 00H - 7FH : Value ignored

Note: mm made valid only when ll is received.

Example: Set the bender range of the part, whose MIDI channel No. is 1, to 2.

MIDI DATA [HEX]	Description
B0 64 00	: RPN LSB = 00
B0 65 00	: RPN MSB = 00
B0 06 02	: MSB of data entry
B0 26 00	: LSB of data entry

2) Master Fine Tune

Set the master tune of DJ-70. When transmitting this message, set the MIDI channel to the control channel number.

RPN	Data entry
MSB LSB	MSB LSB
00H 01H	mmH llH

mm = Upper master fine tune value : 00H - 7FH (0 - 127)

ll = Lower master fine tune value : 00H - 7FH (0 - 127)

Tune can be raised or lowered up to +/- 50 cents with respect to the standard pitch (middle A = 440 Hz) in step of 100/8192 cents. The actual pitch shift is in step of 1 cent. Value less than 20H 00H results in -50 cents and more than 60H 00H +50 cents.

MSB LSB	
20H 00H	-50 cents
:	
40H 00H	0 cent
:	
60H 00H	+50 cents

Example: Set the master tune of DJ-70, whose control channel No. is 16, to A = 440 Hz.

MIDI DATA [HEX]	Description
BF 64 01	:RPN LSB = 01
BF 65 00	:RPN MSB = 00
BF 06 40	:MSB of Data Entry
BF 26 00	:LSB of Data Entry

*** Other Control Changes ***

One of control numbers 0-85 can be received as a controller by using MIDI controller select.

<u>Status</u> BnH	<u>Second</u> mmH	<u>Third</u> vvH		
n = MIDI Channel	: 0H - FH (0 - 15)		0=ch.1	15=ch.16
mm= Control Number	: 00H - 5FH (0 - 95)			
vv = Control Data	: 00H - 7FH (0 - 127)			

● Program Change

<u>Status</u> CnH	<u>Second</u> ppH			
n = MIDI Channel	: 0H - FH (0 - 15)		0=ch.1	15=ch.16
pp = Program Number	: 00H - 7FH (0 - 127)			

* Will perform patch change, performance change according to the MIDI channel number that the DJ-70 has received.

* Patch Change

Can be received when MIDI program change switch is on. Will act as Patch change when received on the channel number of a part. Program number of the patch can be set to a number.

* Performance Change.

Will act as performance change when received on the basic channel number. The program number of performance can be set to a number. Performance change has priority when the channel number and basic channel number of a part conflict.

pp = 00H - 3FH (0 - 63) Performance Change
pp = 40H - 7FH (64 - 127) Performance Change (same as pp - 64)

● Pitch Bend Change

<u>Status</u> EnH	<u>Second</u> llH	<u>Third</u> mmH		
n = MIDI Channel	: 0H - FH (0 - 15)		0=ch.1	15=ch.16
mm, ll = Value	: 00H, 00H - 40H, 00H - 7FH, 7FH			
	(-8192 - 0 - +8191)			

■ Channel Mode Message

● All Note Off

<u>Status</u> BnH	<u>Second</u> 7BH	<u>Third</u> 00H		
n = MIDI Channel	: 0H - FH (0 - 15)		0=ch.1	15=ch.16

* Turns off all MIDI keys on the corresponding MIDI channel except that the damper on has been received. In such a case MIDI-on keys are held on until the damper off is received.

● OMNI OFF

<u>Status</u> BnH	<u>Second</u> 7CH	<u>Third</u> 00H		
n = MIDI Channel	: 0H - FH (0 - 15)		0=ch.1	15=ch.16

* Will act the same as all note off.

● OMNI ON

<u>Status</u> BnH	<u>Second</u> 7DH	<u>Third</u> 00H		
n = MIDI Channel	: 0H - FH (0 - 15)		0=ch.1	15=ch.16

* Will act the same as all note off.

● MONO

<u>Status</u> BnH	<u>Second</u> 7EH	<u>Third</u> mmH		
n = MIDI Channel	: 0H - FH (0 - 15)		0=ch.1	15=ch.16
mm = Mono Channel Range	: Ignored			

* Will act the same as all note off.

● POLY

<u>Status</u> BnH	<u>Second</u> 7FH	<u>Third</u> 00H		
n = MIDI Channel	: 0H - FH (0 - 15)		0=ch.1	15=ch.16

* Will act the same as all note off.

■ System Exclusive Message

<u>Status</u> F0H: System Exclusive	
F7H: EOX (End Of Exclusive)	

* For details refer to "Roland Exclusive Message" and Section 3.

■ System Real Time Message

● Active Sensing

<u>Status</u> FEH

* When DJ-70 receives Active sensing, it measures time intervals between incoming messages. If the subsequent message has not come within 300 ms after the previous one, DJ-70 judges that there is some trouble on MIDI path (broken wiring, etc.) and turns off all MIDI-on notes and then returns to normal operation mode (will not check MIDI message interval).

2. TRANSMITTED DATA

■ Channel Voice Message

● Note Off

<u>Status</u> 8nH	<u>Second</u> kkH	<u>Third</u> vvH		
9nH	kkH	00H		
n = MIDI Channel	: 0H - FH (0 - 15)		0=ch.1	15=ch.16
kk = Note Number	: 15H-6CH (21 - 108)			
	: 00H-01H (0 - 1) Scratch key *			
	: 77H-7FH (119-126) Pad Key			

* 00 = fwd ;01 = rev

● Note On

Status	Second	Third		
9nH	kkH	vvH		
n = MIDI Channel	: 0H - FH (0 - 15)	0=ch.1	15=ch.16	
kk = Note Number	: 15H-6CH (21 - 108)			
	: 00H-01H (0 - 1)	Scratch key *		
	: 77H-7FH (119-126)	Pad Key		
vv = Velocity:	01H-7FH (1 - 127)			

* 00 = fwd ,01 = rev

● Control Change

○ Modulation

Status	Second	Third		
BnH	01H	vvH		
n = MIDI Channel	: 00H - 0FH (0 - 15)	0=ch.1	15=ch.16	
vv = Modulation Depth	: 00H - 7FH (0 - 127)			

* Received when MIDI modulation function is ON.

○ Scratch Control H MSB

Status	Second	Third		
BnH	10H	vvH		
n = MIDI Channel	: 00H - 0FH (0 - 15)	0=ch.1	15=ch.16	
vv = Control Value	: 00H - 7FH (0 - 127)			

* Transmitted when MIDI scratch function is ON.

○ Scratch Control H LSB

Status	Second	Third		
BnH	30H	vvH		
n = MIDI Channel	: 00H - 0FH (0 - 15)	0=ch.1	15=ch.16	
vv = Control Value	: 00H - 7FH (0 - 127)			

* Transmitted when MIDI scratch function is ON.

○ Scratch Control L MSB

Status	Second	Third		
BnH	11H	vvH		
n = MIDI Channel	: 00H - 0FH (0 - 15)	0=ch.1	15=ch.16	
vv = Control Value	: 00H - 7FH (0 - 127)			

* Transmitted when MIDI scratch function is ON.

○ Scratch Control L LSB

Status	Second	Third		
BnH	31H	vvH		
n = MIDI Channel	: 00H - 0FH (0 - 15)	0=ch.1	15=ch.16	
vv = Control Value	: 00H - 7FH (0 - 127)			

* Received when MIDI scratch function is ON.

○ Hold 1

Status	Second	Third		
BnH	40H	vvH		
n = MIDI Channel	: 00H - 0FH (0 - 15)	0=ch.1	15=ch.16	
vv = Control Value	: 00H - 7FH (0 - 127)	0 - 63 = OFF		
		64 - 127 = ON		

* Transmitted when MIDI hold function is ON.

● Program Change

Status	Second			
CnH	ppH			
n = MIDI Channel	: 00H - 0FH (0 - 15)	0=ch.1	15=ch.16	
pp = Program Number	: 00H - 3FH (0 - 63)	Performance change		

* Transmitted when MIDI program change function is on

● Pitch Bend Change

Status	Second	Third		
EnH	llH	mmH		
n = MIDI Channel	: 0H - FH (0 - 15)	0=ch.1	15=ch.16	
mm,ll = Value	: 00H,00H - 40H,00H - 7FH,7FH			
	: (-8192 - 0 - +8191)			

* Transmitted when MIDI pitch bender function is on

■ System Real Time Message

● Active Sensing

Status
FEH

Active sense is always transmitted every 300 milli-second

■ System Exclusive Message

Status
FOH: System Exclusive
F7H: EOX (End Of Exclusive)

* For details refer to "Roland Exclusive Message" and Section 3.

3. Exclusive Communications

■ Exclusive Messages Handled by DJ-70

The DJ-70 transfers the following messages as exclusive messages.

System Exclusive Message (in special format designed by Roland)
Sound Parameter Information and others

Universal System Exclusive Message (in MIDI standard format)
Sample Dump Standard (Sampling data body)

■ System Exclusive Message

● General

With the DJ-70, the system exclusive message can be used to transmit sound parameter and some other information. Exclusive message can be used in two ways: one way communications and handshake communications, each in different format from the other.

● Terminology

○ Model ID

The model ID of the DJ-70 is 53H.

○ Control Channel

This is the channel used to control entire DJ-70. The channel can be set to 1-16.

○ Unit Number

Parameters like MIDI Channel are not available in Exclusive message. Therefore, separate parameters are provided for controlling various parameters.

Parameter Value
Control Channel 1-16 or OFF
Unit Number 17-32 or 1-32

* When unit number is 1-16, its value is synchronized with that of control channel. When the unit number is 17-32, the value can be set independently.

○ Device ID

Device ID is set to a value smaller than the unit number by one. With Roland exclusive message, the device ID is used which contains a unique value that identifies the individual device in the multiple implementation of MIDI instruments. It is usually set to 00H-1FH, a value smaller by one than that of a basic channel (MIDI note information receiving channel). With multiple basic channel unit like the DJ-70, a value is set to 001H-1FH.

● One-way Communications

○ Request Data RQ1 11H

When the DJ-70 receives this message, it first checks whether the specified address matches the parameter base address and the specified address size is one or more. When these checks are satisfactory, it sends the corresponding parameter by using the Data Set 1 (DT1) message. The DJ-70 does not send this message.

Byte	Description
F0H	Exclusive Status
41H	Manufacturer ID (Roland)
DEV	Device ID
53H	Model ID
11H	Command ID (RQ1)
aaH	Address MSB*3-1
aaH	Address
aaH	Address
aaH	Address LSB
ssH	Size MSB
ssH	Size
ssH	Size
ssH	Size LSB
sum	Checksum
F7H	EOX (End Of Exclusive)

○ Data Set DT1 12H

The DJ-70 accepts this message when the following conditions are met.

Matches the MIDI unit number of the MIDI function; and the address specified corresponds to the parameter base address. The DJ-70 stores the received data into location starting with this address.

The DJ-70 transmits this message in the following case.

Having received the request data (RQ1) and to send the data specified by the RQ1.

For details of parameters to be transferred, refer to the parameter address map.

Byte	Description
F0H	Exclusive Status
41H	Manufacturer ID (Roland)
DEV	Device ID
53H	Model ID
11H	Command ID (RQ1)
aaH	Address MSB*3-1
aaH	Address
aaH	Address
aaH	Address LSB
ddH	Data
:	
sum	Checksum
F7H	EOX (End Of Exclusive)

● Handshake Communications

○ Want to Send Data WSD 40H

When DJ-70 receives this message, it transmits acknowledge (ACK) and waits a Data Set (DAT) message.

Byte	Description
F0H	Exclusive Status
41H	Manufacturer ID (Roland)
DEV	Device ID
53H	Model ID
40H	Command ID (WSD)
aaH	Address MSB*3-1
aaH	Address
aaH	Address
aaH	Address LSB
ssH	Size MSB
ssH	Size
ssH	Size
ssH	Size LSB
sum	Checksum
F7H	EOX (End Of Exclusive)

○ Request Data RQD 41H

When the DJ-70 receives this message, it first checks whether the specified address matches the parameter base address and the specified

address size is one or more. When these checks are satisfactory, it sends the corresponding parameter by using the Data Set (DAT) message.

The DJ-70 does not send this message.

Byte	Description
F0H	Exclusive Status
41H	Manufacturer ID (Roland)
DEV	Device ID
53H	Model ID
41H	Command ID (RQD)
aaH	Address MSB*3-1
aaH	Address
aaH	Address
aaH	Address LSB
ssH	Size MSB
ssH	Size
ssH	Size
ssH	Size LSB
sum	Checksum
F7H	EOX (End Of Exclusive)

○ Data Set DAT 42H

When DJ-70 receives this message and the address specified corresponds to the parameter base address, it stores the received data into location starting with this address.

When DJ-70 receives this message, it sends data located within the specified start address and subsequent length of address size, along with the parameter base address.

Byte	Description
F0H	Exclusive Status
41H	Manufacturer ID (Roland)
DEV	Device ID
53H	Model ID
42H	Command ID (DAT)
aaH	Address MSB*3-1
aaH	Address
aaH	Address
aaH	Address LSB
ddH	Data
:	
sum	Checksum
F7H	EOX (End Of Exclusive)

○ Acknowledge ACK 43H

When the DJ-70 receives this message in response to Data Set (DAT), it sends the next data following the data sent in the previous Data Set message, also using Data Set.

When the DJ-70 receives this message in response to End Of Data (EOD), it terminates handshake communication. The DJ-70 sends this message upon receiving Want to send data (WSD). End of data or Data set (DAT).

Byte	Description
F0H	Exclusive Status
41H	Manufacturer ID (Roland)
DEV	Device ID
53H	Model ID
43H	Command ID (ACK)
F7H	EOX (End Of Exclusive)

○ End Of Data EOD 45H

When the DJ-70 receives this message, it terminates handshake communication by sending an acknowledge.

The DJ-70 sends this message when the data is end during bulk dumping.

Byte	Description
F0H	Exclusive Status
41H	Manufacturer ID (Roland)
DEV	Device ID
53H	Model ID
45H	Command ID (EOD)
F7H	EOX (End Of Exclusive)

○ Communication Error ERR 4EH

The DJ-70 sends this message upon detecting receiving error (checksum fails). Upon receiving this message, the DJ-70 sends rejection and then terminates handshake communication.

Byte	Description
F0H	Exclusive Status
41H	Manufacturer ID (Roland)
DEV	Device ID
53H	Model ID
4EH	Command ID (ERR)
F7H	EOX (End Of Exclusive)

○ Rejection RJC 4FH

The DJ-70 sends this message upon receiving a communication error. Upon receiving this message, the DJ-70 terminates current communications.

Byte	Description
F0H	Exclusive Status
41H	Manufacturer ID (Roland)
DEV	Device ID
53H	Model ID
4FH	Command ID (RJC)
F7H	EOX (End Of Exclusive)

● Parameter Address Map

Address is in Hex. and in unit of 7 bits.

Address	MSB	LSB		
Binary	0aaa aaaa	0bbb bbbb	0ccc cccc	0ddd dddd
7 bit Hex	AA	BB	CC	DD

Actual address is the start address of a block plus offset address.

*3-1 Address and Size must specify a location in which data exist.

● Parameter Base Address

○ Temporary Area

Size should not cover more than one parameter area.

Start address	Size	Description
00 00 00 00	64 x 1	Volume Parameter
00 01 00 00	512 x 64	Performance Parameter
00 04 00 00	512 x 128	Patch Parameter
00 08 00 00	256 x 256	Partial Parameter
00 0C 00 00	96 x 512	Sample Parameter
00 0E 7F 7F		End address
01 00 00 00	512 x 64	Added Performance Parameter
01 02 00 00	24576	Song Data

○ Table 1: Volume Parameter.

Offset address	Description
00 00H	0000 aaaa Volume Name 1
00 01H	0000 bbbb aaaa bbbb 32 - 127 (ASCII)
:	
00 1EH	0000 aaaa Volume Name 16
00 1FH	0000 bbbb aaaa bbbb 32 - 127 (ASCII)

○ Table 2: Performance Parameter.

Offset address	Description
00 00H	0000 aaaa Performance Name 1
00 01H	0000 bbbb aaaa bbbb 32 - 127 (ASCII)
:	
00 1EH	0000 aaaa Performance Name 16
00 1FH	0000 bbbb aaaa bbbb 32 - 127 (ASCII)
:	
00 20H	0000 aaaa Part 1 Patch Select
00 21H	0000 bbbb aaaa bbbb 0 - 127
:	
00 5EH	0000 aaaa Part 32 Patch Select
00 5FH	0000 bbbb aaaa bbbb 0 - 127

00 60H	0000 aaaa	Part 1 MIDI Ch			
:		aaaa			0 - 15
00 7FH	0000 aaaa	Part 32 MIDI Ch			
:		aaaa			0 - 15
01 00H	0000 aaaa	Part 1 Level			
01 01H	0000 bbbb	aaaa bbbb			0 - 127
:					
01 3EH	0000 aaaa	Part 32 Level			
01 3FH	0000 bbbb	aaaa bbbb			0 - 127
:					
01 40H	0000 aaaa	Part 1 Zone Range Lower			
01 41H	0000 bbbb	aaaa bbbb			0 - 127
:					
01 7EH	0000 aaaa	Part 32 Zone Range Lower			
01 7FH	0000 bbbb	aaaa bbbb			0 - 127
:					
02 00H	0000 aaaa	Part 1 Zone Range Upper			
02 01H	0000 bbbb	aaaa bbbb			0 - 127
:					
02 3EH	0000 aaaa	Part 32 Zone Range Upper			
02 3FH	0000 bbbb	aaaa bbbb			0 - 127
:					
02 40H	0000 aaaa	Part 1 Zone Fade Width Lower			
02 41H	0000 bbbb	aaaa bbbb			0 - 127
:					
02 7EH	0000 aaaa	Part 32 Zone Fade Width Lower			
02 7FH	0000 bbbb	aaaa bbbb			0 - 127
:					
03 00H	0000 aaaa	Part 1 Zone Fade Width Upper			
03 01H	0000 bbbb	aaaa bbbb			0 - 127
:					
03 3EH	0000 aaaa	Part 32 Zone Fade Width Upper			
03 3FH	0000 bbbb	aaaa bbbb			0 - 127
:					
03 40H	0000 abcd	Program Change Switch			
03 41H	0000 efgh	a Ch 1			
03 42H	0000 ijkl	:		0:Off	1:On
03 43H	0000 mnop	p Ch 16			
:					
03 44H	0000 abcd	Pitch Bender & Bend Range Switch			
03 45H	0000 efgh	a Ch 1			
03 46H	0000 ijkl	:		0:Off	1:On
03 47H	0000 mnop	p Ch 16			
:					
03 48H	0000 abcd	Modulation Switch			
03 49H	0000 efgh	a Ch 1			
03 4AH	0000 ijkl	:		0:Off	1:On
03 4BH	0000 mnop	p Ch 16			
:					
03 4CH	0000 abcd	Hold Pedal Switch			
03 4DH	0000 efgh	a Ch 1			
03 4EH	0000 ijkl	:		0:Off	1:On
03 4FH	0000 mnop	p Ch 16			
:					
03 50H	0000 abcd	Phase Lock Switch			
03 51H	0000 efgh	a Ch 1			
03 52H	0000 ijkl	:		0:Off	1:On
03 53H	0000 mnop	p Ch 16			
:					
03 54H	0000 abcd	MIDI Volume Switch			
03 55H	0000 efgh	a Ch 1			
03 56H	0000 ijkl	:		0:Off	1:On
03 57H	0000 mnop	p Ch 16			
:					
03 58H	0000 abcd	After Touch Switch			
03 59H	0000 efgh	a Ch 1			
03 5AH	0000 ijkl	:		0:Off	1:On
03 5BH	0000 mnop	p Ch 16			
:					
03 5CH	0000 abcd	After Touch Mode			
03 5DH	0000 efgh	a Ch 1			
03 5EH	0000 ijkl	:		0:Ch (0ExH)	1:Poly (0AxH)
03 5FH	0000 mnop	p Ch 16			
:					
03 60H	0000 aaaa	Vel Curve Type Ch 1			
03 61H	0000 bbbb	aaaa bbbb			0 - 4
:					
03 7EH	0000 aaaa	Vel Curve Type Ch 16			
03 7FH	0000 bbbb	aaaa bbbb			0 - 4
Total size		00 04 00H			

○ Table 3: Patch Parameter.

Offset address	Description		
00 00H 00 01H	0000 aaaa 0000 bbbb	Patch Name 1 aaaa bbbb	32 - 127 (ASCII)
:			
00 1EH 00 1FH	0000 aaaa 0000 bbbb	Patch Name 16 aaaa bbbb 32 - 127	(ASCII)
00 20H 00 21H	0000 aaaa 0000 bbbb	Program Change # aaaa bbbb	0 - 127
00 22H 00 23H	0000 aaaa 0000 bbbb	Stereo MIX Level aaaa bbbb	0 - 127
00 24H 00 25H	0000 aaaa 0000 bbbb	Total Panning aaaa bbbb	0 - 31 : L32 - L1 32 : Center 33 - 64 : R1 - R32
00 26H 00 27H	0000 aaaa 0000 bbbb	Patch Level aaaa bbbb	0 - 127
00 28H 00 29H	0000 aaaa 0000 bbbb	Output Assign aaaa bbbb	-1 : Off 0 - 5 : 1 - 6 6 : Partial
00 2AH 00 2BH	0000 aaaa 0000 bbbb	Priority aaaa bbbb	0 : Off 1 : On
00 2CH 00 2DH	0000 aaaa 0000 bbbb	Cutoff aaaa bbbb	-63 - +63
00 2EH 00 2FH	0000 aaaa 0000 bbbb	Velocity Sense aaaa bbbb	-63 - +63
00 30H 00 31H	0000 aaaa 0000 bbbb	Octave Shift aaaa bbbb	-2 - +2
00 32H 00 33H	0000 aaaa 0000 bbbb	Coarse Tune aaaa bbbb	-48 - +48
00 34H 00 35H	0000 aaaa 0000 bbbb	Fine Tune aaaa bbbb	-50 - +50
00 36H 00 37H	0000 aaaa 0000 bbbb	SMT Ctrl Select aaaa bbbb	-1 : Off 0 : Bend 1 : A.T 2 : Mod 3 : Ctrl
00 38H 00 39H	0000 aaaa 0000 bbbb	SMT Ctrl Sense aaaa bbbb	-63 - +63
00 3AH 00 3BH	0000 aaaa 0000 bbbb	Out Assign (8outs Mode) aaaa bbbb	-1 : Off 0 - 7 : 1 - 8 8 : Partial
00 3CH 00 3DH	0000 aaaa 0000 bbbb	Analog Feel aaaa bbbb	0 - 127
00 3EH 00 3FH	0000 aaaa 0000 bbbb	Dummy aaaa bbbb	
00 40H 00 41H	0000 aaaa 0000 bbbb	Partial Select Key # 21 aaaa bbbb	0 - 254
:			
01 6EH 01 6FH	0000 aaaa 0000 bbbb	Partial Select Key # 108 aaaa bbbb	0 - 254
01 70H 01 71H	0000 bbbb 0000 bbbb	Dummy aaaa bbbb	
:			
01 7EH 01 7FH	0000 bbbb 0000 bbbb	Dummy aaaa bbbb	
02 00H 02 01H	0000 bbbb 0000 bbbb	Assign Type aaaa bbbb	Key # 21
:			
03 2EH 03 2FH	0000 bbbb 0000 bbbb	Assign Type aaaa bbbb	Key # 108 0 : Poly 1 : Mono 2 - 17 : Ext 1 - Ext 16

03 30H 03 31H	0000 bbbb 0000 bbbb	Dummy aaaa bbbb	
:			
03 3EH 03 3FH	0000 bbbb 0000 bbbb	Dummy aaaa bbbb	
03 40H 03 41H	0000 bbbb 0000 bbbb	Bender Pitch Ctrl Up aaaa bbbb	0 - +48
03 42H 03 43H	0000 bbbb 0000 bbbb	Bender Pitch Ctrl Down aaaa bbbb	0 - +48
03 44H 03 45H	0000 bbbb 0000 bbbb	Bender TVA Ctrl aaaa bbbb	-63 - +63
03 46H 03 47H	0000 bbbb 0000 bbbb	Bender TVF Ctrl aaaa bbbb	-63 - +63
03 48H 03 49H	0000 bbbb 0000 bbbb	After Touch Pitch Ctrl aaaa bbbb	-48 - +48
03 4AH 03 4BH	0000 bbbb 0000 bbbb	After Touch TVA Ctrl aaaa bbbb	-63 - +63
03 4CH 03 4DH	0000 bbbb 0000 bbbb	After Touch TVF Ctrl aaaa bbbb	-63 - +63
03 4EH 03 4FH	0000 bbbb 0000 bbbb	After Touch LFO Rate Ctrl aaaa bbbb	-63 - +63
03 50H 03 51H	0000 bbbb 0000 bbbb	After Touch LFO Pitch Depth aaaa bbbb	-63 - +63
03 52H 03 53H	0000 bbbb 0000 bbbb	After Touch LFO TVA Depth aaaa bbbb	-63 - +63
03 54H 03 55H	0000 bbbb 0000 bbbb	After Touch LFO TVF Depth aaaa bbbb	-63 - +63
03 56H 03 57H	0000 bbbb 0000 bbbb	Modulation LFO Rate Ctrl aaaa bbbb	-63 - +63
03 58H 03 59H	0000 bbbb 0000 bbbb	Modulation LFO Pitch Depth aaaa bbbb	-63 - +63
03 5AH 03 5BH	0000 bbbb 0000 bbbb	Modulation LFO TVA Depth aaaa bbbb	-63 - +63
03 5CH 03 5DH	0000 bbbb 0000 bbbb	Modulation LFO TVF Depth aaaa bbbb	-63 - +63
03 5EH 03 5FH	0000 bbbb 0000 bbbb	Dummy aaaa bbbb	
03 60H 03 61H	0000 bbbb 0000 bbbb	Controller Select aaaa bbbb	0 - 95
03 62H 03 63H	0000 bbbb 0000 bbbb	Controller Pitch Ctrl aaaa bbbb	-48 - +48
03 64H 03 65H	0000 bbbb 0000 bbbb	Controller TVA Ctrl aaaa bbbb	-63 - +63
03 66H 03 67H	0000 bbbb 0000 bbbb	Controller TVF Ctrl aaaa bbbb	-63 - +63
03 68H 03 69H	0000 bbbb 0000 bbbb	Controller LFO Rate Ctrl aaaa bbbb	-63 - +63
03 6AH 03 6BH	0000 bbbb 0000 bbbb	Controller LFO Pitch Depth aaaa bbbb	-63 - +63
03 6CH 03 6DH	0000 bbbb 0000 bbbb	Controller LFO TVA Depth aaaa bbbb	-63 - +63
03 6EH 03 6FH	0000 bbbb 0000 bbbb	Controller LFO TVF Depth aaaa bbbb	-63 - +63
03 70H 03 71H	0000 bbbb 0000 bbbb	Pitch Mode aaaa bbbb	0 = S-750/S-770 1 = DJ70
03 72H 03 73H	0000 bbbb 0000 bbbb	Scratch Key Number aaaa bbbb	36 - 96
03 74H 03 75H	0000 bbbb 0000 bbbb	Pad Key Number aaaa bbbb	36 - 96
03 76H 03 77H	0000 bbbb 0000 bbbb	Scratch Pitch Sensibility aaaa bbbb	
0 - 100			
:			
03 7EH 03 7FH	0000 bbbb 0000 bbbb	Dummy aaaa bbbb	
Total size		00 04 00H	

○ Table 4: Partial Parameter

Offset address	Description		
00 00H 00 01H	0000 aaaa 0000 bbbb	Partial Name 1 aaaa bbbb	32 - 127 (ASCII)
:			
00 1EH 00 1FH	0000 aaaa 0000 bbbb	Partial Name 16 aaaa bbbb	32 - 127 (ASCII)

00 20H	0000 bbbb	Sample 1 Sample Select			00 60H	0000 bbbb	Sample 3 Sample Select		
00 21H	0000 bbbb	aaaa bbbb cccc dddd	0 -	511	00 61H	0000 bbbb	aaaa bbbb cccc dddd	0 -	511
00 22H	0000 cccc				00 62H	0000 cccc			
00 23H	0000 dddd				00 63H	0000 dddd			
00 24H	0000 bbbb	Sample 1 Pitch KF			00 64H	0000 bbbb	Sample 3 Pitch KF		
00 25H	0000 bbbb	aaaa bbbb	-16 -	+16	00 65H	0000 bbbb	aaaa bbbb	-16 -	+16
00 26H	0000 bbbb	Sample 1 Level			00 66H	0000 bbbb	Sample 3 Level		
00 27H	0000 bbbb	aaaa bbbb	0 -	127	00 67H	0000 bbbb	aaaa bbbb	0 -	127
00 28H	0000 bbbb	Sample 1 Panning			00 68H	0000 bbbb	Sample 3 Panning		
00 29H	0000 bbbb	aaaa bbbb	0 - 31 :	L32 - L1	00 69H	0000 bbbb	aaaa bbbb	0 - 31 :	L32 - L1
			32 :	Center				32 :	Center
			33 - 64 :	R1 - R32				33 - 64 :	R1 - R32
			65 :	Random				65 :	Random
			66 :	Key+				66 :	Key+
			67 :	Key-				67 :	Key-
00 2AH	0000 bbbb	Sample 1 Coarse Tune			00 6AH	0000 bbbb	Sample 3 Coarse Tune		
00 2BH	0000 bbbb	aaaa bbbb	-48 -	+48	00 6BH	0000 bbbb	aaaa bbbb	-48 -	+48
00 2CH	0000 bbbb	Sample 1 Fine Tune			00 6CH	0000 bbbb	Sample 3 Fine Tune		
00 2DH	0000 bbbb	aaaa bbbb	-50 -	+50	00 6DH	0000 bbbb	aaaa bbbb	-50 -	+50
00 2EH	0000 bbbb	Sample 1 SMT Vel Lower			00 6EH	0000 bbbb	Sample 3 SMT Vel Lower		
00 2FH	0000 bbbb	aaaa bbbb	0 -	127	00 6FH	0000 bbbb	aaaa bbbb	0 -	127
00 30H	0000 bbbb	Sample 1 SMT Lower Fade Width			00 70H	0000 bbbb	Sample 3 SMT Lower Fade Width		
00 31H	0000 bbbb	aaaa bbbb	0 -	127	00 71H	0000 bbbb	aaaa bbbb	0 -	127
00 32H	0000 bbbb	Sample 1 SMT Vel Upper			00 72H	0000 bbbb	Sample 3 SMT Vel Upper		
00 33H	0000 bbbb	aaaa bbbb	0 -	127	00 73H	0000 bbbb	aaaa bbbb	0 -	127
00 34H	0000 bbbb	Sample 1 SMT Lower Fade Width			00 74H	0000 bbbb	Sample 3 SMT Lower Fade Width		
00 35H	0000 bbbb	aaaa bbbb	0 -	127	00 75H	0000 bbbb	aaaa bbbb	0 -	127
00 36H	0000 bbbb	Dummy			00 76H	0000 bbbb	Dummy		
00 37H	0000 bbbb	aaaa bbbb			00 77H	0000 bbbb	aaaa bbbb		
00 38H	0000 bbbb	Output Assign (8outs Mode)			00 7EH	0000 bbbb	Dummy		
00 39H	0000 bbbb	aaaa bbbb	-1 :	Off	00 7FH	0000 bbbb	aaaa bbbb		
			0 - 7 :	1 - 8					
00 3AH	0000 bbbb	Stereo MIX Level			01 00H	0000 bbbb	Sample 4 Sample Select		
00 3BH	0000 bbbb	aaaa bbbb	0 -	127	01 01H	0000 bbbb	aaaa bbbb cccc dddd	0 -	511
00 3CH	0000 aaaa	Partial Level			01 02H	0000 cccc			
00 3DH	0000 bbbb	aaaa bbbb	0 -	127	01 03H	0000 dddd			
00 3EH	0000 bbbb	Output Assign			01 04H	0000 bbbb	Sample 4 Pitch KF		
00 3FH	0000 bbbb	aaaa bbbb	-1 :	Off	01 05H	0000 bbbb	aaaa bbbb	-16 -	+16
			0 - 5 :	1 - 6	01 06H	0000 bbbb	Sample 4 Level		
00 40H	0000 bbbb	Sample 2 Sample Select			01 07H	0000 bbbb	aaaa bbbb	0 -	127
00 41H	0000 bbbb	aaaa bbbb cccc dddd	0 -	511	01 08H	0000 bbbb	Sample 4 Panning		
00 42H	0000 cccc				01 09H	0000 bbbb	aaaa bbbb	0 - 31 :	L32 - L1
00 43H	0000 dddd							32 :	Center
00 44H	0000 bbbb	Sample 2 Pitch KF						33 - 64 :	R1 - R32
00 45H	0000 bbbb	aaaa bbbb	-16 -	+16				65 :	Random
00 46H	0000 bbbb	Sample 2 Level						66 :	Key+
00 47H	0000 bbbb	aaaa bbbb	0 -	127				67 :	Key-
00 48H	0000 bbbb	Sample 2 Panning			01 0AH	0000 bbbb	Sample 4 Coarse Tune		
00 49H	0000 bbbb	aaaa bbbb	0 - 31 :	L32 - L1	01 0BH	0000 bbbb	aaaa bbbb	-48 -	+48
			32 :	Center	01 0CH	0000 bbbb	Sample 4 Fine Tune		
			33 - 64 :	R1 - R32	01 0DH	0000 bbbb	aaaa bbbb	-50 -	+50
			65 :	Random	01 0EH	0000 bbbb	Sample 4 SMT Vel Lower		
			66 :	Key+	01 0FH	0000 bbbb	aaaa bbbb	0 -	127
			67 :	Key-	01 10H	0000 bbbb	Sample 4 SMT Lower Fade Width		
00 4AH	0000 bbbb	Sample 2 Coarse Tune			01 11H	0000 bbbb	aaaa bbbb	0 -	127
00 4BH	0000 bbbb	aaaa bbbb	-48 -	+48	01 12H	0000 bbbb	Sample 4 SMT Vel Upper		
00 4CH	0000 bbbb	Sample 2 Fine Tune			01 13H	0000 bbbb	aaaa bbbb	0 -	127
00 4DH	0000 bbbb	aaaa bbbb	-50 -	+50	01 14H	0000 bbbb	Sample 4 SMT Lower Fade Width		
00 4EH	0000 bbbb	Sample 2 SMT Vel Lower			01 15H	0000 bbbb	aaaa bbbb	0 -	127
00 4FH	0000 bbbb	aaaa bbbb	0 -	127	01 16H	0000 bbbb	TVF Filter Mode		
00 50H	0000 bbbb	Sample 2 SMT Lower Fade Width			01 17H	0000 bbbb	aaaa bbbb	0 :	Off
00 51H	0000 bbbb	aaaa bbbb	0 -	127				1 :	LPF
00 52H	0000 bbbb	Sample 2 SMT Vel Upper						2 :	BPF
00 53H	0000 bbbb	aaaa bbbb	0 -	127				3 :	HPF
00 54H	0000 bbbb	Sample 2 SMT Lower Fade Width			01 18H	0000 bbbb	TVF Cutoff		
00 55H	0000 bbbb	aaaa bbbb	0 -	127	01 19H	0000 bbbb	aaaa bbbb	0 -	127
00 56H	0000 bbbb	Dummy			01 1AH	0000 bbbb	TVF Resonance		
00 57H	0000 bbbb	aaaa bbbb			01 1BH	0000 bbbb	aaaa bbbb	0 -	127
00 58H	0000 bbbb	Panning			01 1CH	0000 bbbb	TVF Vel Curve Type		
00 59H	0000 bbbb	aaaa bbbb	0 - 31 :	L32 - L1	01 1DH	0000 bbbb	aaaa bbbb	0 -	3
			32 :	Center					
			33 - 64 :	R1 - R32	01 1EH	0000 bbbb	TVF Vel Curve Ratio		
00 5AH	0000 bbbb	Coarse Tune			01 1FH	0000 bbbb	aaaa bbbb	-63 -	+63
00 5BH	0000 bbbb	aaaa bbbb	-48 -	+48	01 20H	0000 bbbb	TVF Time Vel Sense		
00 5CH	0000 bbbb	Fine Tune			01 21H	0000 bbbb	aaaa bbbb	-63 -	+63
00 5DH	0000 bbbb	aaaa bbbb	-50 -	+50	01 22H	0000 bbbb	TVF Cutoff Vel Sense		
00 5EH	0000 bbbb	SMT Velocity Ctrl			01 23H	0000 bbbb	aaaa bbbb	-63 -	+63
00 5FH	0000 bbbb	aaaa bbbb	0 :	Off	01 24H	0000 bbbb	TVF Time 1		
			1 :	On	01 25H	0000 bbbb	aaaa bbbb	0 -	127
					01 26H	0000 bbbb	TVF Time 2		
					01 27H	0000 bbbb	aaaa bbbb	0 -	127

01 28H	0000 bbbb	TVF Time 3	
01 29H	0000 bbbb	aaaa bbbb	0 - 127
01 2AH	0000 bbbb	TVF Time 4	
01 2BH	0000 bbbb	aaaa bbbb	0 - 127
01 2CH	0000 bbbb	TVF Level 0,4	
01 2DH	0000 bbbb	aaaa bbbb	0 - 127
01 2EH	0000 bbbb	TVF Level 1	
01 2FH	0000 bbbb	aaaa bbbb	0 - 127
01 30H	0000 bbbb	TVF Level 2	
01 31H	0000 bbbb	aaaa bbbb	0 - 127
01 32H	0000 bbbb	TVF Level 3	
01 33H	0000 bbbb	aaaa bbbb	0 - 127
01 34H	0000 bbbb	ENV TVF Depth	
01 35H	0000 bbbb	aaaa bbbb	-63 - +63
01 36H	0000 bbbb	ENV Pitch Depth	
01 37H	0000 bbbb	aaaa bbbb	-63 - +63
01 38H	0000 bbbb	TVF KF Point	
01 39H	0000 bbbb	aaaa bbbb	21 - 108
01 3AH	0000 bbbb	ENV Time KF	
01 3BH	0000 bbbb	aaaa bbbb	-63 - +63
01 3CH	0000 bbbb	ENV Depth KF	
01 3DH	0000 bbbb	aaaa bbbb	-63 - +63
01 3EH	0000 bbbb	Dummy	
01 3FH	0000 bbbb	aaaa bbbb	
01 40H	0000 bbbb	TVA Vel Curve Type	
01 41H	0000 bbbb	aaaa bbbb	0 - 3
01 42H	0000 bbbb	TVA Vel Curve Ratio	
01 43H	0000 bbbb	aaaa bbbb	-63 - +63
01 44H	0000 bbbb	TVA Time Vel Sense	
01 45H	0000 bbbb	aaaa bbbb	-63 - +63
01 46H	0000 bbbb	TVA Time 1	
01 47H	0000 bbbb	aaaa bbbb	0 - 127
01 48H	0000 bbbb	TVA Time 2	
01 49H	0000 bbbb	aaaa bbbb	0 - 127
01 4AH	0000 bbbb	TVA Time 3	
01 4BH	0000 bbbb	aaaa bbbb	0 - 127
01 4CH	0000 bbbb	TVA Time 4	
01 4DH	0000 bbbb	aaaa bbbb	0 - 127
01 4EH	0000 bbbb	TVA Level 0,4	
01 4FH	0000 bbbb	aaaa bbbb	0 - 127
01 50H	0000 bbbb	TVA Level 1	
01 51H	0000 bbbb	aaaa bbbb	0 - 127
01 52H	0000 bbbb	TVA Level 2	
01 53H	0000 bbbb	aaaa bbbb	0 - 127
01 54H	0000 bbbb	TVA Level 3	
01 55H	0000 bbbb	aaaa bbbb	0 - 127
01 56H	0000 bbbb	Dummy	
01 57H	0000 bbbb	aaaa bbbb	
01 58H	0000 bbbb	TVA KF Point	
01 59H	0000 bbbb	aaaa bbbb	21 - 108
01 5AH	0000 bbbb	TVA ENV Time KF	
01 5BH	0000 bbbb	aaaa bbbb	-63 - +63
01 5CH	0000 bbbb	Dummy	
01 5DH	0000 bbbb	aaaa bbbb	
01 5EH	0000 bbbb	TVA Level KF	
01 5FH	0000 bbbb	aaaa bbbb	21 - 108
01 60H	0000 bbbb	LFO Wave Form	
01 61H	0000 bbbb	aaaa bbbb	0: Sin 1: Tri 2: Saw+ 3: Saw- 4: Squ 5: Rnd 6: Bend+ 7: Bend-

01 62H	0000 bbbb	LFO Rate	
01 63H	0000 bbbb	aaaa bbbb	0 - 127
01 64H	0000 bbbb	LFO Key Sync	
01 65H	0000 bbbb	aaaa bbbb	0: Off 1: On
01 66H	0000 bbbb	LFO Delay	
01 67H	0000 bbbb	aaaa bbbb	0 - 127
01 68H	0000 bbbb	LFO Delay KF	
01 69H	0000 bbbb	aaaa bbbb	-63 - +63
01 6AH	0000 bbbb	LFO Detune	
01 6BH	0000 bbbb	aaaa bbbb	0 - 127
01 6CH	0000 bbbb	LFO Pitch Mod Depth	
01 6DH	0000 bbbb	aaaa bbbb	-63 - +63
01 6EH	0000 bbbb	LFO TVF Mod Depth	
01 6FH	0000 bbbb	aaaa bbbb	-63 - +63
01 70H	0000 bbbb	LFO TVA Mod Depth	
01 71H	0000 bbbb	aaaa bbbb	-63 - +63
01 72H	0000 bbbb	Dummy	
01 73H	0000 bbbb	aaaa bbbb	
01 7EH	0000 bbbb	Dummy	
01 7FH	0000 bbbb	aaaa bbbb	
Total size		00 02 00H	

Table 5: Sample Parameter

Offset address	Description
00 00H	0000 bbbb Sample Name 1
00 01H	0000 bbbb aaaa bbbb 32 - 127 (ASCII)
00 1EH	0000 bbbb Sample Name 16
00 1FH	0000 bbbb aaaa bbbb 32 - 127 (ASCII)
00 20H	0000 bbbb Start Point
00 21H	0000 bbbb
00 22H	0000 cccc aaaa bbbb cccc dddd
00 23H	0000 dddd eeee ffff gggg hhhh
00 24H	0000 eeee
00 25H	0000 ffff 70000000H - FFFFFFFFH
00 26H	0000 gggg
00 27H	0000 hhhh
00 28H	0000 bbbb Sustain Loop Start Point
00 29H	0000 bbbb
00 2AH	0000 cccc aaaa bbbb cccc dddd
00 2BH	0000 dddd eeee ffff gggg hhhh
00 2CH	0000 eeee
00 2DH	0000 ffff 70000000H - FFFFFFFFH
00 2EH	0000 gggg
00 2FH	0000 hhhh
00 30H	0000 bbbb Sustain Loop End Point
00 31H	0000 bbbb
00 32H	0000 cccc aaaa bbbb cccc dddd
00 33H	0000 dddd eeee ffff gggg hhhh
00 34H	0000 eeee
00 35H	0000 ffff 70000000H - FFFFFFFFH
00 36H	0000 gggg
00 37H	0000 hhhh
00 38H	0000 bbbb Release Loop Start Point
00 39H	0000 bbbb
00 3AH	0000 cccc aaaa bbbb cccc dddd
00 3BH	0000 dddd eeee ffff gggg hhhh
00 3CH	0000 eeee
00 3DH	0000 ffff 70000000H - FFFFFFFFH
00 3EH	0000 gggg
00 3FH	0000 hhhh
00 40H	0000 bbbb Release Loop End Point
00 41H	0000 bbbb
00 42H	0000 cccc aaaa bbbb cccc dddd
00 43H	0000 dddd eeee ffff gggg hhhh
00 44H	0000 eeee
00 45H	0000 ffff 70000000H - FFFFFFFFH
00 46H	0000 gggg
00 47H	0000 hhhh

00 48H	0000 bbbb	Loop Mode	
00 49H	0000 bbbb	aaaa bbbb	0 : Forward 1 : Fwd+R 2 : OneShot 3 : Fwd+One 4 : Alt 5 : Rev One 6 : Rev
00 4AH	0000 bbbb	dummy	
00 4BH	0000 bbbb	aaaa bbbb	
00 4CH	0000 bbbb	Sustine Loop Tune	
00 4DH	0000 bbbb	aaaa bbbb	-50 - +50
00 4EH	0000 bbbb	Release Loop Tune	
00 4FH	0000 bbbb	aaaa bbbb	-50 - +50
00 50H	0000 bbbb	Segment Top	
00 51H	0000 bbbb	aaaa bbbb cccc dddd	0 - 2044
00 52H	0000 cccc		
00 53H	0000 dddd		
00 54H	0000 bbbb	Segment Length	
00 55H	0000 bbbb	aaaa bbbb cccc dddd	0 - 2045
00 56H	0000 cccc		
00 57H	0000 dddd		
00 58H	0000 bbbb	Sampling Frequency	
	aaaa		0 : 48k 1 : 44.1k 2 : 24k 3 : 22.05k 4 : 30k 5 : 15k
00 59H	0000 bbbb	dummy	
	aaaa		
00 5AH	0000 bbbb	Original Key	
00 5BH	0000 bbbb	aaaa bbbb	21 - 108
00 5CH	0000 bbbb	Dummy	
00 5DH	0000 bbbb	aaaa bbbb	
00 5EH	0000 bbbb	Dummy	
00 5FH	0000 bbbb	aaaa bbbb	
Total size		00 00 60H	

Table 6: Added Performance Parameter.

Offset address	Description	
00 00H	0000 aaaa	Part 1 Pad assign
00 01H	0000 bbbb	aaaa bbbb
:	:	Part 1 Loop mode
:	:	bbbb
:	:	0 - 7
:	:	0 : Forward
:	:	1 : Fwd+R
:	:	2 : Oneshot
:	:	3 : Fwd+one
:	:	4 : Alt
:	:	5 : Revone
:	:	6 : Rev
:	:	7 : Smpl
00 3CH	0000 aaaa	Part 31 Pad assign
00 3DH	0000 bbbb	aaaa bbbb
:	:	Part 31 Loop mode
:	:	bbbb
:	:	0 - 7
00 3EH	0000 bbbb	Dummy
00 3FH	0000 bbbb	aaaa bbbb
00 40H	0000 aaaa	Part 1 Pitch Bender Range
00 41H	0000 bbbb	aaaa bbbb
:	:	0 - 51
:	:	0 : Off
:	:	1-48 : Pitch
:	:	49 : Ptc
:	:	50 : V>
:	:	51 : V<
00 7CH	0000 aaaa	Part 31 Pitch Bender Range
00 7DH	0000 bbbb	aaaa bbbb
:	:	0 - 51

00 7EH	0000 bbbb	Dummy	
00 7FH	0000 bbbb	aaaa bbbb	
01 00H	0000 aaaa	Part 1 Tune	
01 01H	0000 bbbb	aaaa bbbb	-15 - +15
:	:		
01 3CH	0000 aaaa	Part 31 Tune	
01 3DH	0000 bbbb	aaaa bbbb	-15 - +15
01 3EH	0000 bbbb	Dummy	
01 3FH	0000 bbbb	aaaa bbbb	
01 40H	0000 aaaa	Part 1 Kbd Lower Limit	
01 41H	0000 bbbb	aaaa bbbb	36 - 96
:	:		
01 7CH	0000 aaaa	Part 31 Kbd Lower Limit	
01 7DH	0000 bbbb	aaaa bbbb	36 - 96
01 7EH	0000 bbbb	Dummy	
01 7FH	0000 bbbb	aaaa bbbb	
02 00H	0000 aaaa	Part 1 Kbd Upper Limit	
02 01H	0000 bbbb	aaaa bbbb	36 - 96
:	:		
02 3CH	0000 aaaa	Part 31 Kbd Upper Limit	
02 3DH	0000 bbbb	aaaa bbbb	36 - 96
02 3EH	0000 bbbb	Dummy	
02 3FH	0000 bbbb	aaaa bbbb	
02 40H	0000 aaaa	Part 1 Note Shift	
02 41H	0000 bbbb	aaaa bbbb	-99 - 99
:	:		
02 7CH	0000 aaaa	Part 31 Note Shift	
02 7DH	0000 bbbb	aaaa bbbb	-99 - 99
02 7EH	0000 bbbb	Dummy	
02 7FH	0000 bbbb	aaaa bbbb	
03 00H	0000 aaaa	Part 1 Panning	
03 01H	0000 bbbb	aaaa bbbb	-32 - -1 : L32 - L1 0 : Center 1 - 32 : R1 -R32 33 : Ptc
:	:		
03 3CH	0000 aaaa	Part 31 Panning	
03 3DH	0000 bbbb	aaaa bbbb	-32 - -1 : L32 - L1 0 : Center 1 - 32 : R1 -R32 33 : Ptc
:	:		
03 3EH	0000 bbbb	Dummy	
03 3FH	0000 bbbb	aaaa bbbb	
03 40H	0000 aaaa	Part 1 Midi Ch	
03 41H	0000 edcb	aaaa	0 - 15 : Midi Ch
:	:	b	0=off 1=on : Basic Ch
:	:	c	
:	:	d	0=off 1=on : Kbd on/off
:	:	e	0=off 1=on : Midi on/off
03 7CH	0000 aaaa	Part 31 Midi Ch	
03 7DH	0000 edcb	aaaa	0 - 15 : Midi Ch
:	:	b	0=off 1=on : Basic Ch
:	:	c	
:	:	d	0=off 1=on : Kbd on/off
:	:	e	0=off 1=on : Midi on/off
03 7EH	0000 bbbb	Dummy	
03 7FH	0000 bbbb	aaaa bbbb	
Total size		00 04 00H	

Address Map

Address	Block	Sub Block	Reference
00-00-00-00	Volume Parameter		Table 1
00-01-00-00	Performance Parameter	Performance #1	Table 2
		Performance #2	
		:	
		Performance #64	
00-04-00-00	Patch Parameter	Patch #1	Table 3
		Patch #2	
		:	
		Patch #128	
00-08-00-00	Partial Parameter	Partial #1	Table 4
		Partial #2	
		:	
		Partial #256	
00-0C-00-00	Sample Parameter	Sample #1	Table 5
		Sample #2	
		:	
		Sample #512	
00-0E-7F-7F			
01-00-00-00	Added Performance Parameter	Performance #1	Table 6
		Performance #2	
		:	
		Performance #64	
01-02-00-00	Song Data		
01-03-64-00			

■ Universal System Exclusive Message

● Sample Dump Standard

With sample dump standard, the following messages are used to transfer data.

This command requires the sample specified by the number is to be sent. When the DJ-70 receives this command, it first performs checksum of the sample number to see it is within the valid range. If legal, it sends the required data to the command sender. If illegal, the DJ-70 ignores this command.

The DJ-70 will not send this message.

Byte	Description
F0H	Exclusive Status
7EH	Sample Dump Command
ccH	Channel Number
03H	Command ID (Dump Req)
ss ss	Request Sample (LSB first)
F7H	EOX

* Channel Number is the device ID of the System Exclusive Message.

○ Dump Header

The DJ-70 the Dump header when it receives the request dump or it wants to start dump. It terminates dumping upon receiving a cancel. The DJ-70 starts data transfer upon receiving an ACK and will stop sending upon receiving a Wait until it receives the next message. If the DJ-70 has not received any message from the receiving Party within 2 seconds after it sent the dump header, it judges the current communication is open loop (one-way communications) and starts data transmission again.

When the DJ-70 receives this message, it checks whether the memory has more space to accommodate the data and whether the start and end points of sustain loop are correct. If everything is OK to accept the data, it sends ACK and waits for data packet. If not OK, sends a cancel message.

Byte	Description
F0H	Exclusive Status
7EH	Sample Dump Command
ccH	Channel Number
01H	Command ID (Dump Head)
ss ss	Request Sample (LSB first)
10H	Sample Format (16 bits)
ff ff ff	Sample Period (1/sampling rate nS)
gg gg gg	Data(word) Length
hh hh hh	Sustain Loop Start Point (word number)
ii ii ii	Sustain Loop End Point (word number)
jjH	Loop Type
	00H = Forwards only (unidirectional)
	01H = Backwards/Forwards (bi-directional)
	7FH = Off
F7H	EOX

* Channel Number is the Device ID of the System Exclusive Message.

○ Data Packet

Data is sent in a form of 7 bits, at 3 bytes/word (40 words/packet), left justified, upper byte first with a "0" placed at lower 5th bit of the 3rd byte of a word.

Upon receiving the data packet, the DJ-70 checks the checksum: when checksum agrees, it sends ACK and waits for the next packet; if not, sends NAK and requests retransmission of the previous packet.

When the DJ-70 receives Cancel message after sending the data packet, it immediately stops dumping; when receives ACK, it sends the next data packet; when receives Wait, it will not send until it receives the next message.

Byte	Description
F0H	ExclusiveStatus
7EH	Sample Dump Command
ccH	Channel Number
02H	Command ID (Data Packet)
ppH	Packet Number
:	}
:	}
:	} 120 Byte.Data
:	}
:	}
11H	Checksum
F7H	EOX

* Channel Number is the Device ID of the System Exclusive Message.

○ ACK

This handshake flag is sent out when no error was detected on reception of the last packet and the next data is requested to be sent. The Packet Number is the last packet received correctly.

Byte	Description
F0H	Exclusive Status
7EH	Sample Dump Command
ccH	Channel Number
7FH	Command ID (ACK)
ppH	Packet Number
F7H	EOX

* Channel Number is the device ID of the System Exclusive Message.

○ NAK

This handshake flag is sent out when error was detected on reception of the last packet and the same data is requested to be sent again. The Packet Number is the last packet failed to be received.

Byte	Description
F0H	Exclusive Status
7EH	Sample Dump Command
ccH	Channel Number
7EH	Command ID (NAK)
ppH	Packet Number
F7H	EOX

* Channel Number is the device ID of the System Exclusive Message.

○ **Cancel**

This is a handshake flag indicating that the current dump is cancelled. The Packet Number is the packet number cancelled. The cause of this transmission may be overflow at the receiving memory.

<u>Byte</u>	<u>Description</u>
FOH	Exclusive Status
7EH	Sample Dump Command
ccH	Channel Number
7DH	Command ID (Cancel)
ppH	Packet Number
F7H	EOX

* Channel Number is the device ID of the System Exclusive Message.

○ **Wait**

This is a handshake flag inhibiting packet transmission until another message requiring transmission is issued. The Packet Number represents the packet that was not received. This flag is sent out when the receiving device requires a time to become ready for the next reception. An ACK is used to resume transfer; and Cancel is used to cancel the current transmission.

The DJ-70 will not send this message.

<u>Byte</u>	<u>Description</u>
FOH	Exclusive Status
7EH	Sample Dump Command
ccH	Channel Number
7CH	Command ID (Wait)
ppH	Packet Number
F7H	EOX

* Channel Number is the device ID of the System Exclusive Message.

Roland Exclusive Messages

1 Data Format for Exclusive Messages

Roland's MIDI implementation uses the following data format for all exclusive messages (type IV):

Byte	Description
F0H	Exclusive status
41H	Manufacturer ID (Roland)
DEV	Device ID
MDL	Model ID
CMD	Command ID
[BODY]	Main data
F7H	End of exclusive

MIDI status : F0H, F7H

An exclusive message must be flanked by a pair of status codes, starting with a Manufacturer-ID immediately after F0H (MIDI version 1.0).

Manufacturer-ID : 41H

The Manufacturer-ID identifies the manufacturer of a MIDI instrument that triggers an exclusive message. Value 41H represents Roland's Manufacturer-ID.

Device-ID : DEV

The Device-ID contains a unique value that identifies the individual device in the multiple implementation of MIDI instruments. It is usually set to 00H - 0FH, a value smaller by one than that of a basic channel, but value 00H - 1FH may be used for a device with multiple basic channels.

Model-ID : MDL

The Model-ID contains a value that uniquely identifies one model from another. Different models, however, may share an identical Model-ID if they handle similar data.

The Model-ID format may contain 00H in one or more places to provide an extended data field. The following are examples of valid Model-IDs, each representing a unique model:

- 01H
- 02H
- 03H
- 00H, 01H
- 00H, 02H
- 00H, 00H, 01H

Command-ID : CMD

The Command-ID indicates the function of an exclusive message. The Command-ID format may contain 00H in one or more places to provide an extended data field. The following are examples of valid Command-IDs, each representing a unique function:

- 01H
- 02H
- 03H
- 00H, 01H
- 00H, 02H
- 00H, 00H, 01H

Main data : BODY

This field contains a message to be exchanged across an interface. The exact data size and contents will vary with the Model-ID and Command-ID.

2 Address-mapped Data Transfer

Address mapping is a technique for transferring messages conforming to the data format given in Section 1. It assigns a series of memory-resident records-waveform and tone data, switch status, and parameters, for example-to specific locations in a machine-dependent address space, thereby allowing access to data residing at the address a message specifies.

Address-mapped data transfer is therefore independent of models and data categories. This technique allows use of two different transfer procedures: one-way transfer and handshake transfer.

One way transfer procedure (See Section 3 for details.)

This procedure is suited for the transfer of a small amount of data. It sends out an exclusive message completely independent of a receiving device status.

Connection Diagram

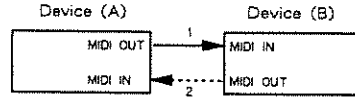

Connection at point 2 is essential for "Request data" procedures. (See Section 3.)

Handshake transfer procedure (This device does not cover this procedure)

This procedure initiates a predetermined transfer sequence (handshaking) across the interface before data transfer takes place. Handshaking ensures that reliability and transfer speed are high enough to handle a large amount of data.

Connection Diagram

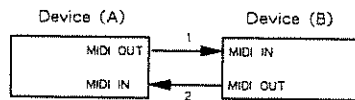

Connection at points 1 and 2 is essential.

Notes on the above two procedures

- * There are separate Command-IDs for different transfer procedures.
- * Devices A and B cannot exchange data unless they use the same transfer procedure, share identical Device-ID and Model ID, and are ready for communication.

3 One way Transfer Procedure

This procedure sends out data all the way until it stops and is used when the messages are so short that answerbacks need not be checked. For long messages, however, the receiving device must acquire each message in time with the transfer sequence, which inserts intervals of at least 20 milliseconds in between.

Types of Messages

Message	Command ID
Request data 1	RQ1 (11H)
Data set 1	DT1 (12H)

Request data # 1 : RQ1 (11H)

This message is sent out when there is a need to acquire data from a device at the other end of the interface. It contains data for the address and size that specify designation and length, respectively, of data required.

On receiving an RQ1 message, the remote device checks its memory for the data address and size that satisfy the request. If it finds them and is ready for communication, the device will transmit a "Data set 1 (DT1)" message, which contains the requested data. Otherwise, the device will send out nothing.

Byte	Description
F0H	Exclusive status
41H	Manufacturer ID (Roland)
DEV	Device ID
MDL	Model ID
11H	Command ID
aaH	Address MSB
⋮	⋮
	LSB
ssH	Size MSB
⋮	⋮
	LSB
sum	Check sum
F7H	End of exclusive

- * The size of the requested data does not indicate the number of bytes that will make up a DT1 message, but represents the address fields where the requested data resides.
- * Some models are subject to limitations in data format used for a single transaction. Requested data, for example, may have a limit in length or must be divided into predetermined address fields before it is exchanged across the interface.
- * The same number of bytes comprises address and size data, which, however, vary with the Model-ID.
- * The error checking process uses a checksum that provides a bit pattern where the least significant 7 bits are zero when values for an address, size, and that checksum are summed.

Data set 1 : DT1 (12H)

This message corresponds to the actual data transfer process. Because every byte in the data is assigned a unique address, a DT1 message can convey the starting address of one or more data as well as a series of data formatted in an address-dependent order.

The MIDI standards inhibit non-real time messages from interrupting an exclusive one. This fact is inconvenient for the devices that support a "soft-through" mechanism. To maintain compatibility with such devices, Roland has limited the DT1 to 256 bytes so that an excessively long message is sent out in separate segments.

Byte	Description
FOH	Exclusive
41H	Manufacturer ID (Roland)
DEV	Device ID
MDL	Model ID
12H	Command ID
aaH	Address MSB
⋮	⋮
	LSB
ddH	Data
⋮	⋮
sum	Check sum
F7H	End of exclusive

- * A DT1 message is capable of providing only the valid data among those specified by an RQ1 message.
- * Some models are subject to limitations in data format used for a single transaction. Requested data, for example, may have a limit in length or must be divided into predetermined address fields before it is exchanged across the interface.
- * The number of bytes comprising address data varies from one Model-ID to another.
- * The error checking process uses a checksum that provides a bit pattern where the least significant 7 bits are zero when values for an address, size, and that checksum are summed.

Example of Message Transactions

● Device A sending data to Device B

Transfer of a DT1 message is all that takes place.

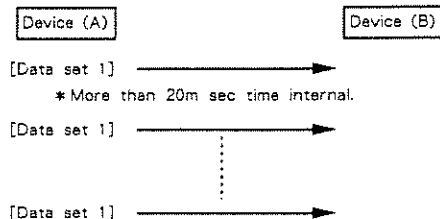

● Device B requesting data from Device A

Device B sends an RQ1 message to Device A: Checking the message. Device A sends a DT1 message back to Device B.

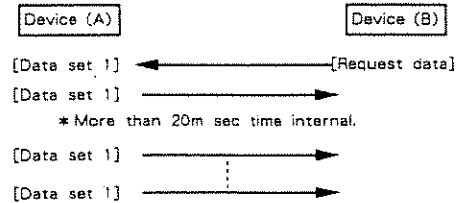

[DJ-70 SAMPLING WORKSTATION]

Date: May. 29. 1992

Model DJ-70

MIDI Implementation Chart

Version: 1.00

Function...		Transmitted	Recognized	Remarks
Basic Channel	Default Changed	1 1-16,OFF	1-16,OFF 1-16,OFF	*2
Mode	Default Message Altered	x x *****	3 x x	
Note Number	True Voice	0-127 *****	0 -127 0 -127	*3
Velocity	Note ON Note OFF	o x	*1 x	v=1-127
After Touch	Key's Ch's	x x	*1 *1	
PitchBend		*1	*1	
Control Change	1 7 64 16 48 17 49 0 - 95 100,101 38,6	*1 x *1 *1 *1 *1 *1 x x x	*1 *1 *1 *1 *1 *1 *1 *1 x x *1 *1	Modulation Volume Hold 1 Scratch H MSB Scratch H LSB Scratch L MSB Scratch L LSB RPN LSB,MSB Data Entry LSB,MSB RPN = 0 Pitch Bend Sensitivity RPN = 1 Master Tune
Prog Change	True #	0 - 63 *1 *****	0-127 *1 0-127	*3
System Exclusive		*1	*1	
System Common	Song Pos Song Sel Tune	x x x	x x x	
System Real Time	Clock Commands	x x	x x	
Aux Messages	Local ON/OFF All Notes OFF Active Sense Reset	x x o x	x o (123-127) o x	
<p>Notes</p> <ul style="list-style-type: none"> *1 Selectable between o and x; result can be memorized *2 Memorized internally. *3 Program change number for each patch can be set. *4 Can be set and saved onto disk. 				

Mode 1 : OMNI ON, POLY
Mode 3 : OMNI OFF, POLY

Mode 2 : OMNI ON, MONO
Mode 4 : OMNI OFF, MONO

o : Yes
x : No

Information

When you need repair service, call your local Roland Service Station or the authorized Roland distributor in your country as shown below.

U. S. A.

Roland Corporation US
7200 Dominion Circle
Los Angeles, CA.
90040-3647, U. S. A.
☎ (213)685 - 5141

CANADA

Roland Canada Music Ltd.
(Head Office)
5480 Parkwood
Richmond B. C., V6V 2M4
CANADA
☎ (604)270 - 6626

Roland Canada Music Ltd.
9425 Transcanadienne
Service Rd. N., St Laurent,
Quebec H4S 1V3,
CANADA
☎ (514)335 - 2009

Roland Canada Music Ltd.
346 Watline Avenue,
Mississauga, Ontario L4Z
1X2, CANADA
☎ (416)890 - 6488

AUSTRALIA

Roland Corporation
(Australia) Pty. Ltd.
(Head Office)
38 Campbell Avenue
Dee Why West, NSW 2099
AUSTRALIA
☎ (02)982 - 8266

Roland Corporation
(Australia) Pty. Ltd.
(Melbourne Office)
50 Garden Street
South Yarra, Victoria 3141
AUSTRALIA
☎ (03)241 - 1254

UNITED KINGDOM

Roland(U.K.) Ltd.
Rye Close
Ancells Business Park
Fleet, Hampshire GU13
8UY, UNITED KINGDOM
☎ 0252 - 816181

Roland(U.K.) Ltd.,
Swansea Office
Atlantic Close, Swansea
Enterprise Park, Swansea,
West Glamorgan SA79FJ,
UNITED KINGDOM
☎ (0792)700 - 139

ITALY

Roland Italy S. p. A.
Viale delle Industrie 8
20020 ARESE MILANO
ITALY
☎ 02 - 93581311

SPAIN

Roland Electronics
de España, S. A.
Calle Bolivia 239
08020 Barcelona, SPAIN
☎ 93 - 308 - 1000

GERMANY

Roland Elektronische
Musikinstrumente
Handelsgesellschaft mbH.
Oststrasse 96, 2000
Norderstedt, GERMANY
☎ 040/52 60 090

FRANCE

Musikengro
102 Avenue Jean-Jaures
69007 Lyon Cedex 07
FRANCE
☎ (7)858 - 54 60

Musikengro (Paris Office)
Centre Region Parisienne
41 rue Charles-Fourier,
94400 Vitry s/Seine
FRANCE
☎ (1)4680 86 62

BELGIUM/ HOLLAND/ LUXEMBOURG

Roland Benelux N. V.
Houtstraat 1
B-2260 Oevel-Westerlo
BELGIUM
☎ (0032)14 - 575811

DENMARK

Roland Scandinavia A/S
Langebrogade 6
Box 1937
DK-1023 Copenhagen K.
DENMARK
☎ 31 - 95 31 11

SWEDEN

Roland Scandinavia A/S
DanvikCenter 28 A, 2 tr.
S-131 30 Nacka
SWEDEN
☎ 08 - 702 00 20

NORWAY

Roland Scandinavia
Avd. Norge
Lilleakerveien 2
Postboks 95 Lilleaker
N-0216 Oslo 2
NORWAY
☎ 02 - 73 00 74

FINLAND

Fazer Musik Inc.
Länsituulentie
POB 169
SF-02101 Espoo
FINLAND
☎ 0 - 43 50 11

NEW ZEALAND

Roland Corporation
(NZ) Ltd.
97 Mt. Eden Road, Mt.
Eden, Auckland 3,
NEW ZEALAND
☎ (09)3098 - 715

SWITZERLAND

Musitronic AG
Gerberstrasse 5, CH-4410
Liestal, SWITZERLAND
☎ 061/921 16 15

Roland CK (Switzerland)
AG
Postfach/Hauptstrasse 21
CH-4456 Tenniken
SWITZERLAND
☎ 061/98 60 55
Repair Service by
Musitronic AG

AUSTRIA

E. Dematte & Co.
Neu-Rum Siemens-
Strasse 4
A-6021 Innsbruck Box 591
AUSTRIA
☎ (0512)63 451

GREECE

V. Dimitriadis & Co. Ltd.
2 Phidiou Str., GR 106 78
Athens, GREECE
☎ 1 - 3620130

PORTUGAL

Casa Caius Instrumentos
Musicais Lda.
Rua de Santa Catarina 131
Porto, PORTUGAL
☎ 02 - 38 44 56

HUNGARY

Intermusica Ltd.
Warehouse Area 'DEPO'
Torokbalint, Budapest
HUNGARY
☎ (1)1868905

ISRAEL

D.J.A. International Ltd.
25 Pinsker St., Tel Aviv
ISRAEL
☎ 972 - 3 - 5283015

CYPRUS

Radex Sound Equipment
Ltd.
17 Panteli Katelari Str.
P.O.Box 2046, Nicosia
CYPRUS
☎ 453426, 466423

TURKEY

Barkat Sanayi ve Ticaret
Siraselviler Cad. 86/6
Taksim Istanbul, TURKEY
☎ 149 93 24

EGYPT

Al Fanny Trading Office
9, Ebn Hagar Askalany
Street, Ard El Golf,
Heliopolis, Cairo, EGYPT
☎ 2917803 - 665918

BRAZIL

Roland Brasil Ltda.
R. Alvarenga 591
CEP-05509 Sao Paulo
BRAZIL
☎ (011)813 - 7967
Repair Service for Roland
and Rhodes products

Oliver do Brasil S.A.
Instrumentos Musicais
Av. Ceci. No.578 Centro
Empresarial Tambore
Barueri SP CEP 06400
BRAZIL
☎ (011)709 - 1267
Repair Service for BOSS
products

MEXICO

Case Veerkamp, s.a. de c.v.
Mesones No. 21
Col. Centro
C.P. 06080 Mexico, D.F.
MEXICO
☎ (5)709 - 3716

La Casa Wagner de
Guadalajara s.a. de c.v.
Av. Corona No. 202 S.J.
C.P.44100
Guadalajara, Jalisco
MEXICO
☎ (36)13 - 1414

ARGENTINA

Netto S.A.
Venezuela 1433
1095 Buenos Aires
ARGENTINA
☎ 37 - 1632

HONG KONG

Tom Lee Music Co., Ltd.
Service Division
22-32 Pun Shan Street,
Tsuen Wan, New
Territories, HONG KONG
☎ 415 - 0911

KOREA

Cosmos Corporation
Service Station
261 2nd Floor Nak-Won
arcade
Jong-Ro ku, Seoul, KOREA
☎ (02) 742 8844

SINGAPORE

Swee Lee Company
Bras Basah Complex
#03-23 Singapore 0178
SINGAPORE
☎ 3367886

THAILAND

Theera Music Co., Ltd.
330 Verng Nakorn Kasem,
Soi 2, Bangkok 10100,
THAILAND
☎ 2248821

MALAYSIA

Syarikat Bentley
No.142, Jalan Bukit
Bintang 55100 Kuala
Lumpur, MALAYSIA
☎ 2421288

INDONESIA

PT Galestra Inti
Kompleks Perkantoran
Duta Merlin Blok C/59
Jl. Gajah mada No.3-5
Jakarta 10130
INDONESIA
☎ (021) 354604, 354606

TAIWAN

Siruba Enterprise(Taiwan)
Co., LTD.
Room. 5. 9fl. No. 112
Chung Shan N.Road Sec.2
Taipei, TAIWAN, R.O.C.
☎ (02)5364546

SOUTH AFRICA

That Other Music
Shop(PTY) LTD.
256 Bree Street,
Johannesburg 2001
Republic of South Africa
☎ 337 - 6573

Paul Bothner(PTY) LTD.

17 Werdmuller Centre
Claremont 7700
Republic of South Africa
☎ 021 - 64 - 4030

HOW TO INSERT THE TWO OMS-770 (SIMM) TO EXPAND YOUR DJ-70

Fig. 1 - Remove the 11 screws as indicated by (A) arrows to open the cabinet of DJ-70, and rotate top cover.

Fig. 2 - Remove the 5 screws as indicated by (B) arrows to take out the keyboard.

Fig. 3 - **How to install the 2 pcs. of OMS-770**

Install the two OMS-770 into the sockets as shown in fig. 3 and press them until you hear a click.

Caution!

- 1) Two OMS-770 of 1Mbyte each must be installed. If just one single unit is installed, the DJ-70 will not recognize it.
- 2) The OMS-770 is the official memory expansion for the DJ-70. If memory modules other than OMS-770 are used, Roland cannot be responsible for faulty operation or for service of any resulting malfunctions.
- 3) Your Roland technician or dealer is best qualified to make the installation. Do not attempt any operation by yourselves.

How to verify the operation when memory has been expanded

After expanding memory and closing the instrument, turn on your DJ-70 and the amount of currently operative memory will be displayed immediately after the initial display: in this case, the LCD should show **4Mbytes**.

EINBAU DER SPEICHERERWEITERUNG (ZWEI 1MB SIMMs OMS-770, SONDERZUBEHÖR)

Fig. 1 - Entfernen Sie zunächst die 11 Schrauben, welche mit "A" bezeichnet sind, und öffnen Sie dann das Gehäuse-Oberteil.

Fig. 2 - Entfernen Sie danach die 5 Schrauben, die mit "B" bezeichnet sind, um die Tastatur herausnehmen zu können.

Fig. 3 - **Installieren der SIMMs-Chips:**

Stecken Sie die zwei Chips wie in Abb. 3 angegeben in die dafür vorgesehenen Sockel, bis diese einrasten.

Wichtige Hinweise

- 1) Der DJ-70 erkennt die SIMMs nur, wenn zwei 1MB Chips installiert wurden.
- 2) Vom Hersteller werden die Speicherchips Roland OMS-770 empfohlen. Bei Verwendung anderer 1MB SIMMs kann keine Garantie für die Funktionstüchtigkeit übernommen werden.
- 3) Lassen Sie die Installation von Ihrem Roland-Fachhändler durchführen. Führen Sie keine eigene Modifikation durch. Nachdem der DJ-70 wieder ordnungsgemäß zusammengebaut und eingeschaltet wurde, ist der neue Speicherwert im Display sichtbar ("**4Mbytes**").

COMMENT INSERER LES DEUX OMS-770 (SIMM) POUR AMPLIFIER LE DJ-70

Fig. 1 - Enlevez les 11 vis comme indiqué par les flèches (A) pour ouvrir le couvercle du DJ-70, et faites-le tourner.

Fig. 2 - Enlevez les 5 vis comme indiqué par les flèches (B) pour ôter le clavier.

Fig. 3 - **Comment installer les deux OMS-770**

Installez les deux OMS-770 dans les socles comme indiqué dans la fig. 3 et pressez-les jusqu'à ce que vous entendiez un dé clic.

Précautions

- 1) Deux OMS-770 de 1Mbyte chaque doivent être installées. Si une seule unité est installée, le DJ-70 ne la reconnaîtra pas.
- 2) OMS-770 est l'expansion de mémoire officielle du DJ-70. Si vous utilisez des modules de mémoire autres qu'OMS-770, Roland ne peut être responsable des mauvaises opérations ou des réparations à la suite de ces mauvaises opérations.
- 3) Votre technicien ou revendeur Roland sont les plus qualifiés pour l'installation de ces modules. N'essayez de faire aucune opération par vous-mêmes.

Comment vérifier l'opération après expansion de la mémoire

Après avoir amplifié la mémoire de votre DJ-70, et l'avoir fermé, allumez-le: la quantité de mémoire opérative sera affichée, immédiatement après le premier affichage: dans ce cas, l'afficheur indiquera **4Mbytes**.

COME INSERIRE LE DUE OMS-770 (SIMM) PER ESPANDERE IL VOSTRO DJ-70

Fig. 1 - Svitare le 11 viti indicate con (A) per aprire il DJ-70 e ruotare poi il coperchio.

Fig. 2 - Svitare le 5 viti indicate con (B) e togliere la tastiera.

Fig. 3 - **Come installare le due SIMM OMS-770**

Inserire le due SIMM negli zoccoli come indicato nella fig. 3 e premerle fino a quando udirete un click.

Attenzione!

- 1) Devono essere installate due SIMM OMS-770 da 1 Mbyte cad. Se viene montata una sola SIMM, il DJ-70 non la riconoscerà.
- 2) La OMS-770 è l'espansione ufficiale per il DJ-70. Se vengono usati moduli diversi, la Roland non assume responsabilità per un cattivo funzionamento o per conseguenti riparazioni.
- 3) Non effettuate mai direttamente le operazioni qui descritte. Rivolgetevi sempre a un tecnico Roland o al vostro negoziante Roland.

Come verificare che l'espansione della memoria sia avvenuta

Dopo aver inserito l'espansione e richiuso lo strumento, accendete il DJ-70. La videata immediatamente susseguente alla prima vi indicherà con quali memorie il DJ-70 opera. In questo caso sul display (LCD) apparirà la scritta **4Mbytes**.

OMS-770 (SIMM) 2個をDJ-70へインストールするには

Fig.1: Aで示された位置にある11個のネジをはずしてDJ-70のキャビネットを開き、上部カバーを取り外します。

Fig.2: Bで示された位置にある5個のネジをはずして、鍵盤部を取り外します。

Fig.3: OMS-770のインストールのしかた

OMS-770を2個、カチッと音がするまで穴に差し込んで取り付けます。

注意

- (1) 必ず1メガバイトのOMS-770を2個インストールしてください。1個しかインストールしていない場合は使用できません。
- (2) OMS-770はDJ-70専用の拡張メモリーです。OMS-770以外のメモリーを使った場合の故障については責任を負いません。
- (3) インストールの際はローランド・サービスまたは販売店に御相談ください。ご自分でインストールすることはおやめください。メモリー拡張時の動作確認のしかた

メモリーをインストールし、キャビネットを閉じたあと、DJ-70の電源を入れます。初期画面に続いて、使用可能なメモリーの量がディスプレイに表示されます。この場合は、ディスプレイに"4Mbytes"と表示されます。

Fig. 1

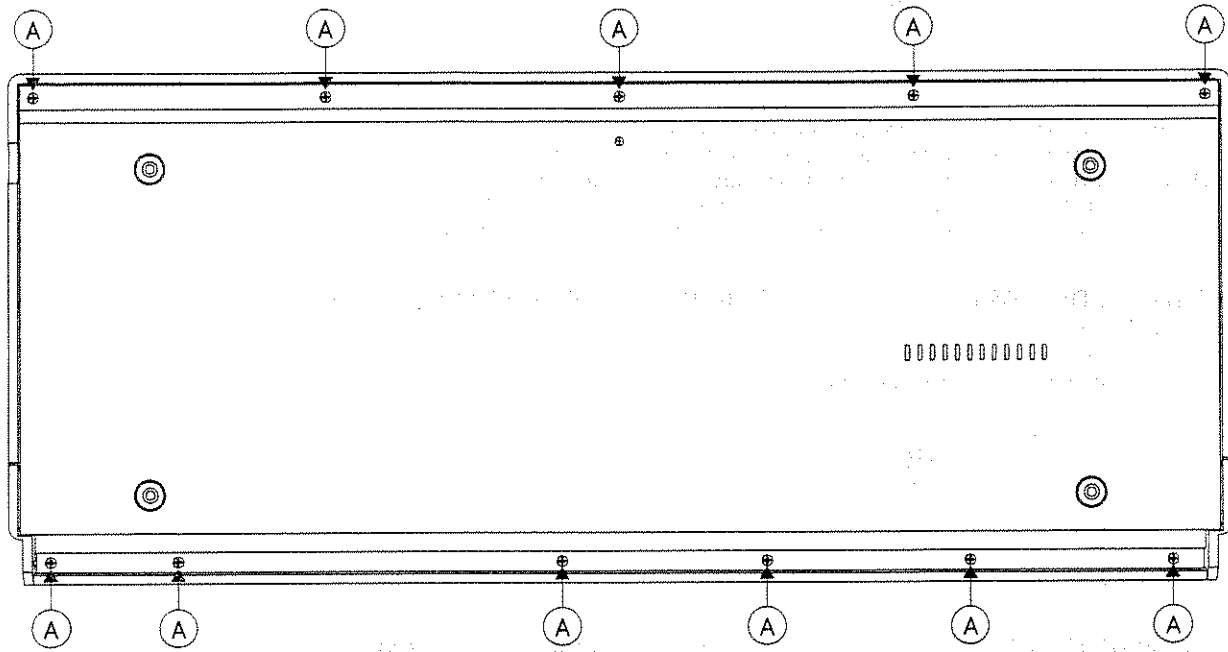

Fig. 2

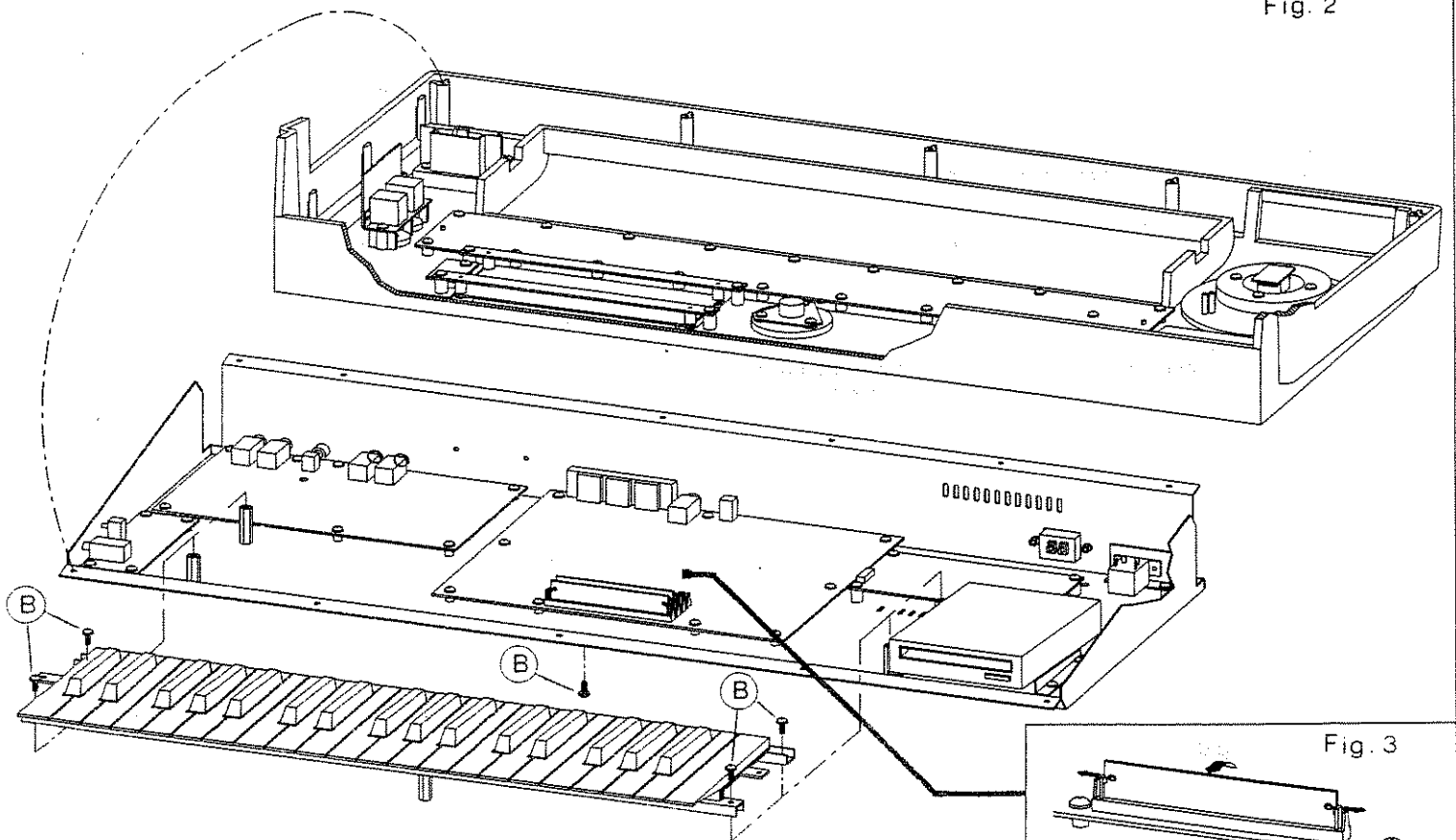



Fig. 3

	CAUTION RISK OF ELECTRIC SHOCK DO NOT OPEN	
ATTENTION : RISQUE DE CHOC ELECTRIQUE NE PAS OUVRIR		
<p>CAUTION: TO REDUCE THE RISK OF ELECTRIC SHOCK, DO NOT REMOVE COVER (OR BACK). NO USER-SERVICEABLE PARTS INSIDE. REFER SERVICING TO QUALIFIED SERVICE PERSONNEL.</p>		



The lightning flash with arrowhead symbol, within an equilateral triangle, is intended to alert the user to the presence of un-insulated "dangerous voltage" within the product's enclosure that may be of sufficient magnitude to constitute a risk of electric shock to persons.



The exclamation point within an equilateral triangle is intended to alert the user to the presence of important operating and maintenance (servicing) instructions in the literature accompanying the product.

INSTRUCTIONS PERTAINING TO A RISK OF FIRE, ELECTRIC SHOCK, OR INJURY TO PERSONS.

IMPORTANT SAFETY INSTRUCTIONS

WARNING — When using electric products, basic precautions should always be followed, including the following:

1. Read all the instructions before using the product.
2. Do not use this product near water — for example, near a bathtub, washbowl, kitchen sink, in a wet basement, or near a swimming pool, or the like.
3. This product should be used only with a cart or stand that is recommended by the manufacturer.
4. This product, either alone or in combination with an amplifier and headphones or speakers, may be capable of producing sound levels that could cause permanent hearing loss. Do not operate for a long period of time at a high volume level or at a level that is uncomfortable. If you experience any hearing loss or ringing in the ears, you should consult an audiologist.
5. The product should be located so that its location or position does not interfere with its proper ventilation.
6. The product should be located away from heat sources such as radiators, heat registers, or other products that produce heat.
7. Avoid using the product where it may be affected by dust.
8. The product should be connected to a power supply only of the type described in the operating instructions or as marked on the product.
9. The power-supply cord of the product should be unplugged from the outlet when left unused for a long period of time.
10. Do not tread on the power-supply cord.
11. Do not pull the cord but hold the plug when unplugging.
12. When setting up with any other instruments, the procedure should be followed in accordance with instruction manual.
13. Care should be taken so that objects do not fall and liquids are not spilled into the enclosure through openings.
14. The product should be serviced by qualified service personnel when:
 - A. The power-supply cord or the plug has been damaged; or
 - B. Objects have fallen, or liquid has been spilled into the product; or
 - C. The product has been exposed to rain; or
 - D. The product does not appear to operate normally or exhibits a marked change in performance; or
 - E. The product has been dropped, or the enclosure damaged.
15. Do not attempt to service the product beyond that described in the user-maintenance instructions. All other servicing should be referred to qualified service personnel.

For the USA

GROUNDING INSTRUCTIONS

This product must be grounded. If it should malfunction or breakdown, grounding provides a path of least resistance for electric current to reduce the risk of electric shock.

This product is equipped with a cord having an equipment-grounding conductor and a grounding plug. The plug must be plugged into an appropriate outlet that is properly installed and grounded in accordance with all local codes and ordinances.

DANGER: Improper connection of the equipment-grounding conductor can result in a risk of electric shock. Check with a qualified electrician or serviceman if you are in doubt as to whether the product is properly grounded. Do not modify the plug provided with the product — if it will not fit the outlet, have a proper outlet installed by a qualified electrician.

SAVE THESE INSTRUCTIONS

For the U.K.

WARNING: THIS APPARATUS MUST BE EARTHED

IMPORTANT: THE WIRES IN THIS MAINS LEAD ARE COLOURED IN ACCORDANCE WITH THE FOLLOWING CODE.
GREEN-AND-YELLOW: EARTH, BLUE: NEUTRAL, BROWN: LIVE

As the colours of the wires in the mains lead of this apparatus may not correspond with the coloured markings identifying the terminals in your plug proceed as follows:

The wire which is coloured GREEN-AND-YELLOW must be connected to the terminal in the plug which is marked by the letter E or by the safety earth symbol  or coloured GREEN or GREEN-AND-YELLOW.

The wire which is coloured BLUE must be connected to the terminal which is marked with the letter N or coloured BLACK.

The wire which is coloured BROWN must be connected to the terminal which is marked with the letter L or coloured RED.

The product which is equipped with a THREE WIRE GROUNDING TYPE AC PLUG must be grounded.

 Roland®

10846

UPC 10846



1998

DJ-70

Res 028-92 Printed in Italy by Adh. Tecnografica s.r.l. 92-05-DJ-70

 Roland