

# Service Manual

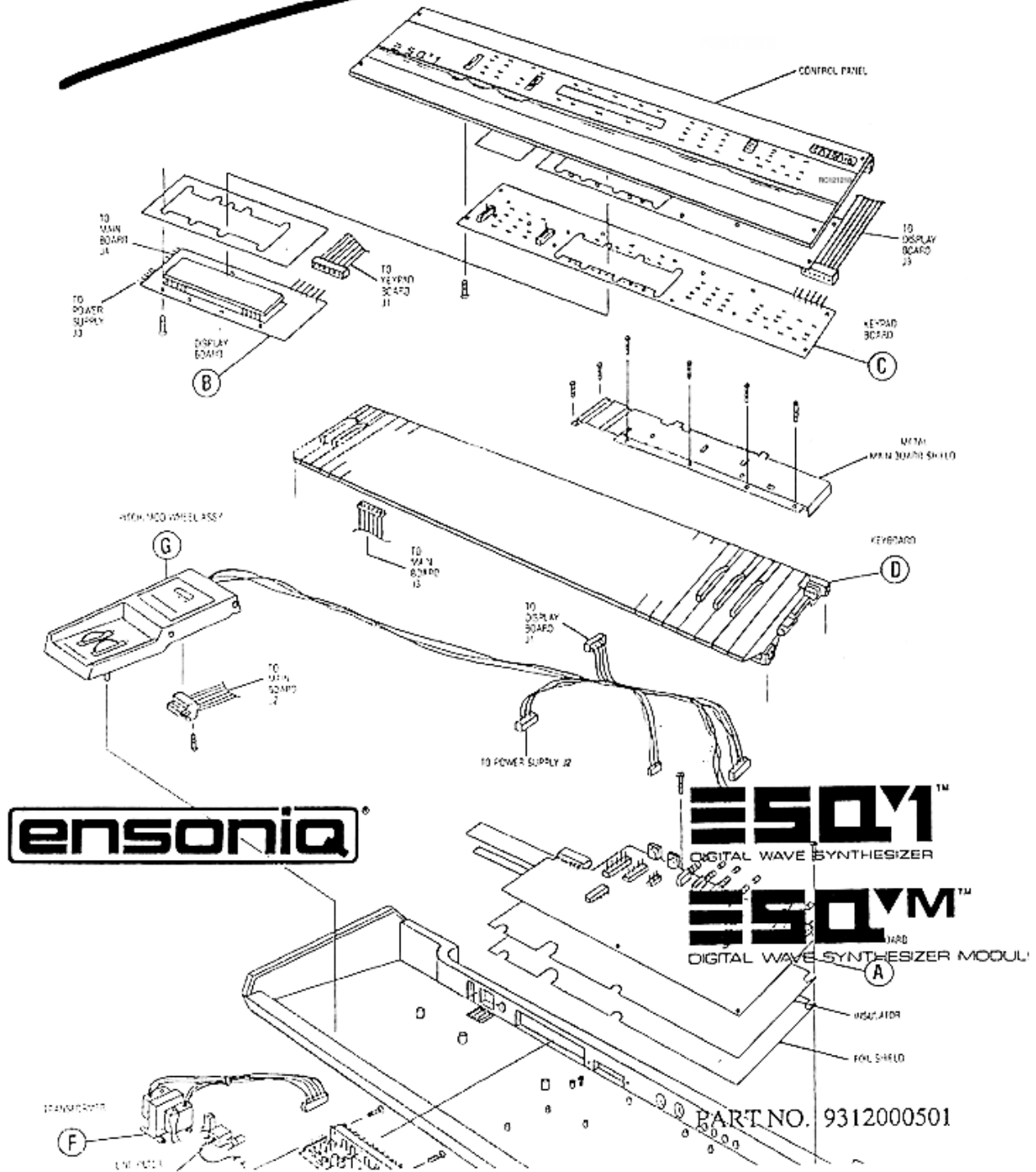

## INTRODUCTION

As with every ENSONIQ product, all ESQ-1 service will be handled through the ENSONIQ Module Exchange Program. Rather than diagnose and exchange individual components, you will replace complete modules. We feel this is the most time and cost effective method of repair, both for you and your customers.

The ESQ-1 Service manual is divided into four different sections and includes service information on both the ESQ-1 Digital Wave Synthesizer and the ESQ-M Digital Wave Synthesizer Module. In April of 1987, ENSONIQ replaced the Metal Case of the ESQ-1 with a Plastic Case. You can use the following criteria to determine which case is which:

<u>STYLE</u>	<u>SERIAL # RANGE</u>	<u>MAINBOARD ASSY #</u>	<u>DISTINGUISHING FEATURE</u>
METAL	10000 - 24999	40900004001	NO HEAT SINK ON BACK
PLASTIC	25000 - HIGHER	40900007001	HEAT SINK ON BACK

There are no interchangeable parts between the metal and plastic ESQ-1. There is service information, however, that applies to both types of cases. It is for this reason that you find sections of the manual dedicated to: both the metal and plastic ESQ-1 (Section 1), the metal ESQ-1 only (Section 2), the plastic ESQ-1 only (Section 3) and the ESQ-M (Section 4).

## TABLE OF CONTENTS

### *Figure 1 ESQ-1 Front Panel Controls*

#### **METAL AND PLASTIC ESQ-1 (Section 1)**

Internal memory	2
ESQ-1 Test Procedure	2
1. Memory Protect Test	2
2. Memory Backup Test	2
3. Analog Input Test	2
4. Sustain Jack Test	3
5. Sequencer Jack Test	3
6. Cartridge Test	3
7. Keypad Test	3
8. Stereo Test	4
9. Tape Output Test	4
10. Tape Input Test	4
11. Filter Tune	5
12. Sound Test	5
13. MIDI Test	5
14. Re-initialization Of ESQ-1	5
15. Hard Reset	5
Using Self-Test Mode to Diagnose Display Assemblies	6
Software Notes O.S. 1.7 thru O.S. 3.5	7, 8
Hardware Notes	8
Battery Low Message	9
System Error Message	9, 10
Flowchart - Troubleshooting an ESQ-1 with a Blank Display	10

#### **Metal ESQ-1 (Section 2)**

<i>Figure 2 ESQ-1 Metal Exploded View</i>	
Checking the Power Supply	13
<i>Figure 3 AC Line Voltage Check Points</i>	13
Power Supply Measurements	14
<i>Figure 4 Power Supply Voltage Check Points</i>	14
Testing the Power Supply Unloaded	15
Hardware Notes (specific to the Metal ESQ-1)	16
<i>Figure 5 Intermittent Start-up Problem Modification</i>	17
Section A Replacing the Main Board	18

<b>Metal ESQ-1 (Continued)</b>		
Section B	Replacing the Display Board	18, 19
Section C	Replacing the Keypad Board	19
Section D	Replacing the Keyboard	19
Section E	Replacing the Power Supply	20
Section F	Replacing the Transformer	20
Section G	Replacing the Pitch/Mod Wheel Assembly	21
Section H	Replacing the Line Filter	21
Section I	Replacing the Operating System EPROMs	22
<b>Plastic ESQ-1 (Section 3)</b>		
<i>Figure 6 ESQ-1 Plastic Exploded View</i>		
Checking the Power Supply		25
<i>Figure 7 AC Line Voltage Check Points</i>		25
Power Supply Measurements		26
<i>Figure 8 Power Supply Voltage Check Points</i>		26
Testing the Power Supply Unloaded		27
Hardware Notes (specific to the Plastic ESQ-1)		27, 28
<i>Figure 9 Intermittant Start-up Problem Modification</i>		28
Section A	Replacing the Main Board	29
Section B	Replacing the Display Board	29
Section C	Replacing the Keypad Board	30
Section D	Replacing the Keyboard	30, 31
<i>Figure 10 Bottom of ESQ-1 Plastic Case</i>		31
Section E	Replacing the Power Supply	31, 32
Section F	Replacing the Transformer	32
Section G	Replacing the Pitch/Mod Wheel Assembly	32
Section H	Replacing the Line Filter	33
Section I	Replacing the Operating System EPROMs	33
Section J	Installing Ferrite Bead	34
<i>Figure 10A Ferrite Bead Installation</i>		34
<b>ESQ-M (Section 4)</b>		
<i>Figure 11 ESQ-M Exploded View</i>		
Internal Memory		37
Checking the Power Supply		37
Transformer and Power Supply Voltage Points		37
Power Supply Measurements		38
Testing the Power Supply Unloaded		38, 39
ESQ-M Test Procedure		39
1. Getting to the Hidden Functions Page		39
2. Initial Setup		39
3. Keypad Test		39
4. Re-initialization Of ESQ-M		39
5. Filter Tune		39
6. Analog Test		40
7. Load from Cartridge Test		40
8. Write to Cartridge Test		40
9. Memory Protect Test		40
10. Stereo Test		40
11. Sound Test		41
12. Re-initialization Of ESQ-M		41
13. Burn-in Routine		41
Software Notes and Hardware Notes		41
Section A	Replacing the Main Board	42
Section B	Replacing the Keypad/Display Board	42
Section C	Replacing the Power Supply	43
Section D	Replacing the Transformer	43
Section E	Replacing the Line Filter	43
Section F	Replacing the Operating System EPROM	44

# FRONT PANEL CONTROLS

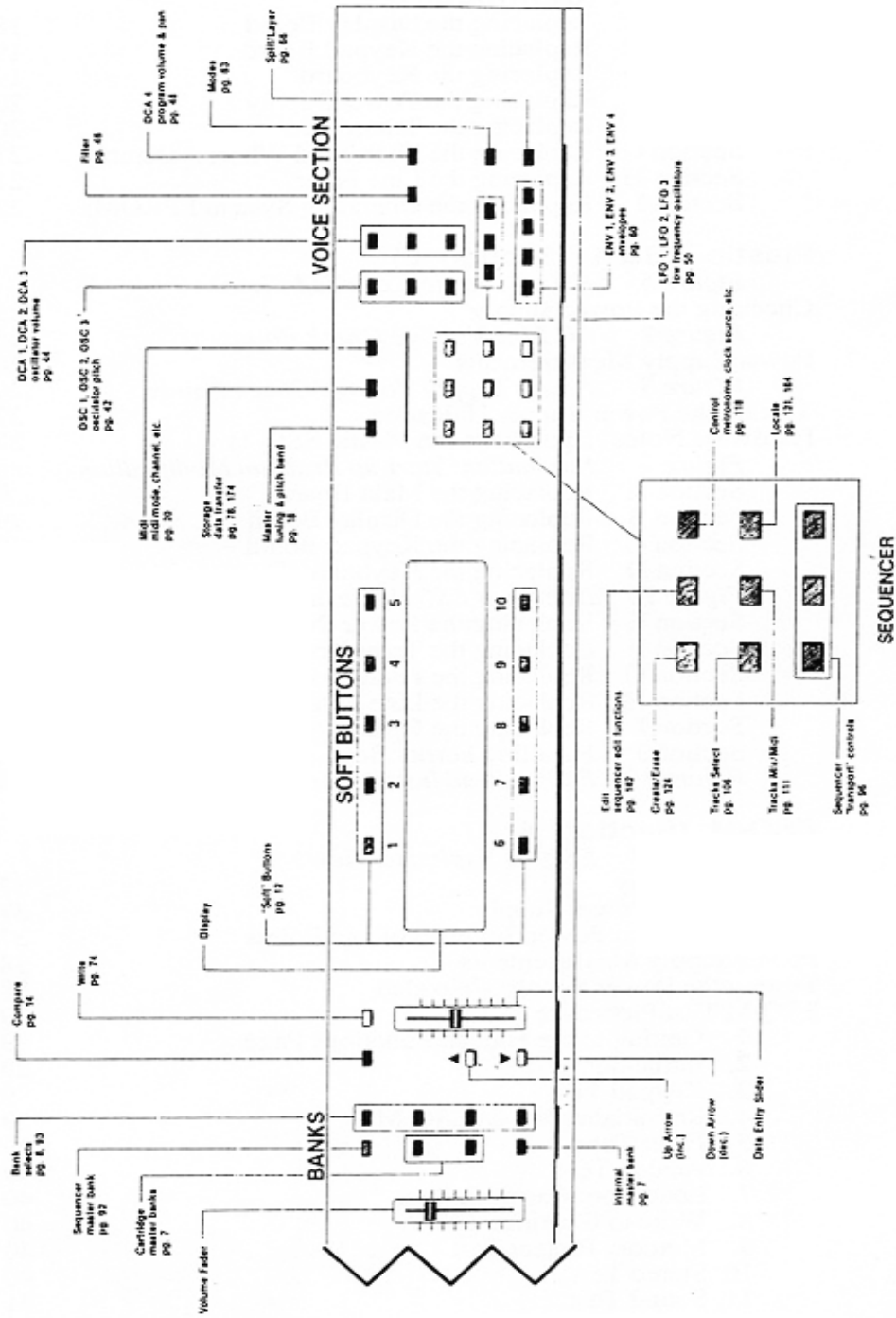

Figure 1 — ESQ-1 Front Panel Controls

# ESQ SERVICE MANUAL

---

## ***SECTION 1: Metal and Plastic***

## INTERNAL MEMORY

A given ESQ-1 is likely to have Program and/or Sequence data in its internal memory that is near and dear to the owner of that unit. In the event that it becomes necessary to re-initialize the memory during repairs, it is **highly** recommended that the internal memory (both Programs and Sequences) of the unit be saved before servicing. For instructions on saving data to: a Mirage (via MIDI) or tape, see the ESQ-1 Musician's Manual; a device with Sys-Ex capabilities or MIDI disk drive see the Version 3 software update sheet.

## ESQ-1 TEST PROCEDURE

The following procedure will ensure the thorough testing of the ESQ-1 and will also aid in trouble-shooting the unit. To perform the following tests you will need a Cassette Tape Deck with a short MIDI cable, a Foot Switch, a Control Voltage (CV) Pedal and an STC-8 E<sup>2</sup>PROM Storage Cartridge. The ESQ-1 should be connected in stereo to a sound system.

The ESQ-1 is heavily software dependent, and certain events can cause the unit to glitch and contract a severe case of amnesia. Sometimes these units merely require re-initialization (see page 5, Step 14). Since scrambled software can cause problems that at first glance appear to be hardware-related, the use of correlation modules, particularly a known-good Keypad and Display unit, is strongly recommended.

If the Keypad and Display are unknowns, it can cause confusion in tracking down the problem. If you do not have known-good correlation modules and suspect a Display or Keypad problem, you should test these modules first (see Using Self-Test Mode, page 6)

### 1. Memory Protect Test

- A. While holding the **RECORD** button, press the **MASTER** button. The sign-on message should appear.
- B. Flip the Power Switch off and on 5 times, allowing the sign-on screen to be displayed each time.
- C. Press the **INTERNAL** button.
- D. Select each Bank and verify that Program names are not scrambled.
- E. While in each Bank, select any Program using the Soft buttons and play it to verify that the sound is not scrambled.
- F. Press the **SEQ** button, select a Sequence using the Soft buttons.
- G. Press the **CONTROL** button, select **COUNTOFF** and set it to **CLICK**.
- H. Press **PLAY** and listen for the Metronome countoff click.
- I. Allow the Sequence to play for a short time to verify that the Sequence data is not scrambled.
- J. Press **STOP/CONT** to stop the Sequence.
- \* Failure to retain Internal Programs and Sequences or failure to hear the metronome indicates a Main Board problem.

### 2. Memory Backup Test

- A. Turn the unit off.
- B. Wait 10 seconds.
- C. Turn the unit back on and verify that the Program memories have not reverted to **BRASS 1** (for OS 2.2 or lower).
- \* Failure to retain Internal Programs indicates a Main Board problem.

**NOTE:** For units with OS versions 2.3 or higher, you must test the memory back-up by first creating a sequence and then verifying that it is retained after the unit is turned off and then on again.

### 3. Analog Input Test

- A. While holding down the **RECORD** button, press the **COMPARE** button.
- B. Repeatedly press the **"READ"** Soft button and verify each of the following:
  1. **PTCH** reads:
    - a. between 110 and 150 when the Pitch Wheel is centered.
    - b. 30 or lower when Pitch Wheel is down.
    - c. 220 or higher when Pitch Wheel is up.
  2. **MOD** reads
    - a. 0 when the Mod Wheel is down.
    - b. at least 240 when Wheel is up.
  3. **KNOB** moves from 0 to 255 when the Data Entry Slider is moved.

4. *PED* moves from 0 to 255 when the Pedal is moved.
5. *BAT* reads 0.

C. Make sure the Pitch Wheel is not being held off-center and press **\*READ\*** one more time.

\* **Failure on this page indicates a problem with the corresponding part, although it could also indicate a Power Supply failure or a Main Board problem. If all the readings are off, then it is most likely that there is a problem with the Main Board.**

#### 4. Sustain Jack Test

Plug the Foot Switch into the Sustain Ft. Sw. Jack and verify that notes sustain when the switch is depressed and follow their normal decay when it is released.

\* **Failure indicates a Main Board problem.**

#### 5. Sequencer Jack Test

Plug the Foot Switch into the Sequencer Ft. Sw. Jack and verify that you can start and stop the Sequencer with alternate depressions of the switch.

\* **Failure indicates a Main Board problem.**

#### 6. Cartridge Test

A. Insert an STC-8 E<sup>2</sup>PROM Storage Cartridge into the Program Cartridge Slot.

B. Press the CART A button and verify that all four Banks can be selected and that none of the names are garbled.

C. Repeat step B for CART B.

D. Press the WRITE button, and then select the Soft button above **\*YES\***.

E. Select a location in memory to store the selected program.

F. The display should respond **WRITING NEW PROGRAM...** and return to normal with no errors after 4 seconds.

G. Remove the STC-8 Cartridge.

\* **Failure usually indicates a Main Board problem. Check the Cartridge cable, however, to see that it is installed correctly (stripe at pin 1) and that none of the connectors' pins are offset or bent under.**

**NOTE:** In some cases, a defective main board can garble the contents of the STC-8. If this happens, reload the STC-8 from a known-good ESQ-1 by copying the data from a good STC-8 over the garbled data. See the *ESQ-1 Musician's Manual* for details.

#### 7. Keypad Test

A. After pressing INTERNAL, press each Soft button to verify that the appropriate Program name gets underlined.

B. Press each button in the VOICE section and verify that they select the proper pages. (The name of each Page, which corresponds to the button pressed, appears in the upper-left corner of the display.)

C. Press the MASTER, STORAGE and MIDI buttons in the SEQUENCER section and verify that they select the proper pages.

D. Press the CREATE/ERASE, EDIT, CONTROL, SELECT, MIX/MIDI and LOCATE buttons and verify that they select the proper pages.

E. Test the Sequencer Transport controls (RECORD, START/STOP and PLAY) to verify their proper operation.

F. Press the up arrow key. The Tempo should increase.

G. Press the down arrow key. The Tempo should decrease.

\* **Failure most likely indicates a problem with the Keypad. Display Board and Main Board problems, however, also affect the Keypad function.**

**NOTE:** It is possible that on early metal units leads on the back of the Keypad Board are shorting to components on the Display Board. If the unit functions properly with the Display board detached from the case (but still connected electrically) then this shorting is almost certainly the problem (see Hardware Notes--Metal on p. 16).

## 8. Stereo Test

- A. Press the DCA 4 button and select *PAN*.
  - B. Using the Data Entry Slider, move the Pan value to 0 and play more than 8 notes. There should only be sound coming from the left channel.
  - C. Move the Pan value to 15 and play more than 8 notes. There should only be sound coming from the right channel.
  - D. Unplug the RIGHT Output and play notes while moving the Pan value up and down. There should only be sound coming from the left channel and adjusting the Pan setting should have no effect.
- \* Failure indicates a Main Board problem.

## 9. Tape Output Test

**NOTE:** The tape interface on the ESQ-1 is very level-sensitive. We recommend that a good quality tape deck with variable output control be used, and that levels be set at 0 dB for best results. Also, be sure to switch off any noise reduction (see Hardware Notes--Metal on p. 8).

- A. Connect the Tape Out Jack to the input of the Tape Deck.
  - B. Rewind the tape.
  - C. Press the STORAGE button, and select *TAPE SAVE*.
  - D. Start the Tape Deck recording and then select *INT BANKS*. If no level shows on the Tape Deck's meters, check your connections and level settings. If any signal is recorded on the tape, it is safe to assume that the tape output is working correctly.
  - E. After 50 seconds, the display should return to normal.
  - F. Rewind the tape.
- \* Failure usually indicates a Main Board problem.

## 10. Tape Input Test

- A. Connect the Tape In Jack to the output of the Tape Deck.
  - B. While holding down the RECORD button, press Soft button #1.
  - C. Answer *\*YES\** to re-initialize the system (see Re-initialization of Unit, page 5).
  - D. Press the STORAGE button, and select *TAPE LOAD*.
  - E. Start tape playback and, after the leader tone appears on the Tape Deck's level meters, select *INT BANKS*.
  - F. After 50 seconds, the display should return to normal without error.
  - G. Press the INTERNAL button and select each Bank to verify the Program names have not been scrambled.
- \* If the Tape Input on the Main Board is not functional, the message *TAPE NOT STARTED ON LEADER* will always appear. If the Tape loads for a while and then the Display reports *FATAL ERRORS DETECTED*, it is highly unlikely that there is a problem with the Main Board. It is much more likely that the tape level is not set properly. See *TAPE TIPS* (Hardware Notes, p. 8).

## 11. Filter Tune

- A. While holding the RECORD button, press the FILTER button.
  - B. The value for each filter will be displayed sequentially. Verify that all numbers are between 140 and 160 inclusive.
- \* Failure indicates a Main Board problem.

## 12. Sound Test

- A. Select your favorite patch and play.
  - B. Play all of the keyboard keys and check for velocity sensitivity.
  - C. Adjust the Volume Slider to make sure it has the appropriate effect on Volume.
- \* Failure usually indicates a Main Board or Volume Slider problem. One dead key would indicate a keyboard problem. Eight or more dead keys could indicate a keyboard or keyboard cable problem.



### 13. MIDI Test

- A. Connect MIDI In to MIDI Out with a MIDI cable.
- B. Hold down a few keys.
- C. Disconnect one end of the MIDI cable.
- D. When you release the keys, the notes should sustain.
- E. Play eight or more keys simultaneously to re-initialize the voices.
- \* **Failure indicates a Main Board problem.**

### 14. Re-Initialization of Unit

The following procedure is not a normal part of the test, and should only be performed in the event that the software becomes scrambled or if indicated as part of another procedure in this manual. **WARNING:** All sounds and sequences will be lost in the re-initialization process. Save any important data before re-initializing.

- A. While holding the **RECORD** button, press Soft button #1.
- B. Display should read **ERASE ALL MEMORY AND RE-INITIALIZE**.
- C. Select **\*YES\***.
- D. The display will return to the sign-on message. All RAM is erased and all internal Programs reset.

**NOTE:** When re-initializing with O.S. Version 2.2 or lower, all internal programs will be reset to **BRASS 1**. Higher versions will load the forty factory sounds.

- E. Tune the Filters (see **Filter Tune**, step 11).
- F. For units with O.S. version 2.2 and lower, load internal Program Memory from an STC-8 E<sup>2</sup>PROM Storage Program Cartridge:
  - 1. Press the **Storage** button.
  - 2. Select the Soft button below **CARTRIDGE**.
  - 3. Select **CART A TO INT**.
  - 4. Select **\*YES\***. The data transfer takes about 2 seconds.

Re-load the Internal Programs and Sequences via tape before beginning the test procedure.

### 15. Hard Reset

If you are unable to re-initialize the unit due to scrambled software (i.e. the keypad not responding), you can clear the RAM by following this procedure:

- 1. **Make sure the power is off!**
- 2. FOR METAL UNITS: short the right side lead of CR1 to C1.  
FOR PLASTIC UNITS: short the right side lead of C18 to the left side lead of CR3.

You should now be able to re-initialize the unit as described above.

## USING SELF-TEST MODE TO DIAGNOSE DISPLAY ASSEMBLIES

1. If the unit comes in with a blank display, but is in Self-test mode (i.e. the Display prints out characters when front panel buttons are pressed in accordance with the following chart) this indicates the problem is either the Main Board or the communication link between the Main Board and the Display Board. Before replacing anything, check all connections, particularly the four (4) wire connector to the Display Board. Test the Main Board with a known good Display board to determine whether the Main Board or Display Board is at fault. If the Main Board is at fault, try re-initializing the RAM as outlined in Step 15 of the ESQ-1 Test Procedure (page 5).
2. If the display is blank and remains blank (not in Self-test mode), turn the unit OFF, open the front panel, and disconnect the four-wire connector from the Display Board. This interrupts communications between the Main Board and the Display Board. Close the lid and turn the power ON. If the unit now enters the Self-test mode, this indicates a Main Board problem. If removing the four-wire connector from the Display Board does not activate the Self-test mode (assuming all power supply voltages checked out properly), this indicates a faulty Display Board.
3. If the unit is in Self-test mode but the display does not respond according to the above chart, the problem is most likely in the Keypad or in the Display Board. If certain buttons do not function properly during normal ESQ-1 operation, test them while the unit is in Self-Test mode. If the same buttons do function properly in Self-Test mode, then the problem is most likely scrambled software (the unit must be re-initialized as in Step 15 of the ESQ-1 Test Procedure (page 5).

When the Display and Keypad assemblies are receiving power from the Power Supply but are not in proper communication with the Main Board, the ESQ-1 enters Self-test mode. In Self-test mode, the Display remains blank until you press the buttons on the front panel. Pressing various front panel buttons will cause the Display to print characters, underscore characters, clear the screen, etc. The Chart below details how the front panel buttons are mapped in Self-Test Mode:

<u>Press:</u>	<u>Display Reads:</u>	<u>Press:</u>	<u>Display Reads:</u>
SEQ	9.	Master	(Backup Cursor)
CART A	Down arrow	Create/Erase	(Clear Screen)
CART B	Space	Tracks Select	(Clear Line 1)
Internal	*	Record	(Clear Line 2)
BANK 1	?	Storage	(Underscore at Cursor)
BANK 2	<	EDIT	(Underscore at Cursor + Adv. Cursor)
BANK 3	>	Tracks Mix	(Erase Underscore at Cursor)
BANK 4	Up arrow	Stop	(Erase Underscore at Cursor + Adv. Cursor)
Compare	7.	MIDI	(Underscore 5 Characters)
Up/Inc.	0	Control	(Underscore 6 Characters)
Down/Dec.	1	Locate	(Underscore 7 Characters)
Write	2	Play	(Underscore 8 Characters)
Soft But. #1	3	OSC 1	(Erase Underscore 5 Characters)
Soft But. #2	4	OSC 2	(Erase Underscore 6 Characters)
Soft But. #3	5	OSC 3	(Erase Underscore 7 Characters)
Soft But. #4	6	ENV 1	(Erase Underscore 8 Characters)
Soft But. #5 (Enter Flashing Underscore mode)	DCA 1	\$	
Soft But. #6	7	DCA 2	'
Soft But. #7	8	DCA 3	=
Soft But. #8	9	Filter	Space
Soft But. #9 (Enter Flashing Mode)	ENV 3	Space	
Soft But. #10 (Enter Normal Mode)	ENV 4	Space	
LFO 1 (Enter Underscore Mode)	DCA 4	Space	
LFO 2	8.	MODES	Space
LFO 3	+	Split/Layer	Space
ENV 2	(Advance Cursor)		

## SOFTWARE NOTES

The following are problems that have been identified in Software version 1.7 which might lead to a system crash or other user problem:

1. Selecting a different song while a sequence is running can cause the system to crash.
2. Performing any of the following sequencer functions when there is very little sequencer memory remaining can cause the system to crash:
  - a. Saving or merging a track
  - b. Erasing a track
  - c. Recording a track
3. The system will occasionally lock up after loading data from MIDI. The data is transferred intact, but the ESQ-1 never returns from flashing **PLEASE WAIT**. Turning the unit Off and On again cures the problem.
4. The first time that MIDI data is loaded after powering up the unit, the unit has a tendency to fail to load; the display will read: **TARGET SYSTEM NOT RESPONDING**, even though all connections are correct. The data load will be successful if tried again.
5. Due to "jitter" on the part of the Data Entry Slider, parameters on Programming pages and Tempo on Sequence pages will sometimes jump to the present value of the slider.

The following are problems that have been identified in Software version 2.0 which might lead to a user problem:

1. With version 2.0, it is possible to set the pitch bend range outside the legal limit (to values of 49 to 63) It is necessary to re-initialize the unit to re-set pitch bend to the proper range of 0 to 12.
2. The sequencer sometimes fails to accurately record sustain pedal information.
3. The sequencer will sometimes play back key down events with velocity of 0 if the key had been recorded with a low velocity value.
4. In MIDI MONO mode, the ESQ-1 may not properly receive program changes on all channels.
5. When syncing to tape, the sequencer will sometimes play the first note of the sequence as soon as the user presses play, putting the rest of the sequence out of sync.

The following are changes that have been included in Software version 2.2 :

1. A parameter was added to allow the CV Pedal to be used as a volume pedal as well as a Mod Pedal.
2. Allowed data dumps to disk drives capable of accepting generic system exclusive messages.
3. Allowed compatibility with MIDI Guitar controller.
4. Ability to output a tape sync clock when syncing to MIDI clocks as well as when syncing to tape.

The following are changes that have been included in Software version 2.3:

1. 40 internal programs are reloaded after reinitialization.
2. Fixed a bug which caused erratic operation when using the LOCATE function by more than 16 bars.

The following are changes that have been included in Software version 3.0:

1. Added sequence editing features which allows addition and deletion of variable bars at any boundary within a sequence.
2. Ability to rename songs by pressing the soft button above the song name on the SONG EDIT page.
3. Allowed startup screen to automatically switch to last selected internal page.
4. VELOCITY parameter renamed to TOUCH.

The following is a change that was included in Software version 3.1:

1. Ability to remain in SONG mode even after unit was turned off.

## SOFTWARE NOTES CONTINUED...

The following is a change that was included in Software version 3.4:

1. Corrected a sequencer problem which prevented the ESQ-1 from recording correctly when synchronized (SYNC=MIDI CLOCK) with units which send clocks continuously.

The following are changes that have been included in Software version 3.5:

1. Corrected waveform pointer in EPNO2 waveform.
2. Restored the values of the TOUCH parameters to their original and correct order (HARD, MED, SOFT).

## HARDWARE NOTES

### Button Presses when Writing a Program

1. In some units there have been problems selecting certain program positions. This problem shows up either when holding down Bank 1 and Soft button #10, or when holding down Cart A and Soft button #7. Swapping the Display board should fix the problem. If the customer doesn't want the Display board swapped, the work around is as follows:

Bank 1 and Soft button #10 — press Bank 1, the hold down Internal and press Soft button #10  
Cart A and Soft button #7 — press Cart A, the hold down the proper Bank button and press Soft button #7

Three button presses *in any order* are needed to tell the ESQ-1 what to select. This work around just changes the order in which the three buttons are pressed.

### 2. Tape Tips

- A. When saving data to a home-type deck with level controls and VU meters, make sure the record level is high enough (right near 0 dB seems to work best). Too low a record level will bury the data in tape hiss.
- B. When loading, wait 4 to 6 seconds into the leader tone before pressing the ESQ-1 button that starts the procedure. This lets the tone "settle out," and lets the recorder get up to speed.
- C. If the recorder doesn't have a level meter, listen for the leader tone before starting Tape Load operation.
- D. When loading from a recorder that has a tone control, make sure it is in the flat position. Lots of treble boost or cut will distort the pulse waveforms on the tape.
- E. **\*TAPE NOT STARTED ON LEADER TONE\*** may mean the level is too low.  
**\*FATAL ERRORS DETECTED -- ALL INTERNAL PROGRAM RESET\*** may mean the level is too high.

Generally, the correct input level will fall in between the levels which yield the above messages. If you get the **\*TAPE NOT STARTED ON LEADER TONE\*** message, and you know that the tape was started on the tone, then the level is too low. If you then increase the level, and get the **FATAL ERRORS DETECTED -- ALL INTERNAL PROGRAMS RESET\*** message, the level is now too high. Try a level between the two. (Of course, the above messages may mean just what they say.)

**NOTE:**ESQ-1's updated from version 1.X or 2.X O.S. to a version 3.X O.S. may experience loading problems. Users may need to establish a higher volume level so they can load in their old data dumps.

## BATTERY LOW MESSAGE

A number of things could cause this message to appear when the unit is powered up:

### WARNING - BATTERY VOLTAGE IS LOW SAVE DATA AND CONSULT OWNERS MANUAL

Sometimes the unit in question can wake up in a state of mild confusion and this message might appear. Go to the Analog Test Page (while holding *Record*, press *Compare*). Repeatedly press the soft button below **READ**. The value next to **BAT** should read 000. If this is the case, it usually indicates that the system is confused and you should re-initialize (while holding *Record*, press Soft button #1, then press the Soft button above **YES**), tune the filters (while holding *Record*, press *Filter*), and check it again.

If the message continues to appear, or the value next to **BAT** reads greater than 20:

1. **Check Power Supply**  
Check the power supply voltages loaded and unloaded (as described in the Service Manual), paying particular attention to the +12A and -12A. If these voltages are off by more than the allowable 10% in either direction (+ or -), the circuit that reads the battery voltage will give unreliable results. *This indicates a power supply problem.*
2. **Check Battery Voltage**  
If the power supply voltages are OK, turn the unit OFF and measure the voltage across the battery. The voltage across the battery should measure no less than 2.7VDC. If the voltage is less than 2.7VDC, *the battery needs to be replaced*. After replacing the battery, recheck the voltage across the battery and check the main board as described in Step 3 below to ensure that the main board isn't loading down the battery.
3. **Check Main Board**  
If the battery voltage is correct and the message continues to appear, check the following to make sure that the main board isn't loading down the battery.
  - a. **Metal** Check CR1  
**Plastic** Check CR3  
The voltage across this diode should measure no more than 400mVDC.
  - b. **Metal** Check U19, U20  
**Plastic** Check U14, U18  
If the voltage measured at the battery, minus approximately 400mVDC (the drop across the diode) is not present at both the diode and the RAM chips, *this indicates a main board problem.*
4. It is possible that a faulty memory expander (SQX-10 or SQX-20) is draining the battery. If you suspect the cartridge, remove it and perform the above tests again.

## SYSTEM ERROR MESSAGES

System Error 1 - Buffer Overflow

System Error 2 - This message should never occur on the ESQ-1

System Error 3 - DUART Unrecognized Command

It is important to realize that these messages are intended as diagnostics and do not necessarily indicate a problem. *These messages are not fatal*. You can press any button to continue. It is possible that these messages could result from scrambled memory. As usual, you may want to try re-initializing the system (don't forget to tune the filters). If the message is still chronic, see the following page:

- # 1 This error could occur if too much MIDI information is coming in. This may indicate a problem in the MIDI interconnections between the **ESQ-1** and other devices. Of course, there may simply be too much information being sent to the **ESQ-1** for it to deal with. All MIDI devices have a limit on how much MIDI information they can process before they get overloaded. Our system tells you when it is getting too much, most other products simply choke or crash.
- # 2 This message should never occur on the **ESQ-1**.
- # 3 This message should only occur upon power up. Due to a bug in the DUART chip, O.S. Versions 3.0 to 3.2 could cause chronic SYSTEM ERROR 3 messages at power up.

Prior to software version 3.0, system errors were not displayed. If the unit had a problem, it would automatically go to the wake-up screen and not give you any hints as to why.

### TROUBLESHOOTING AN ESQ-1 WITH A BLANK DISPLAY

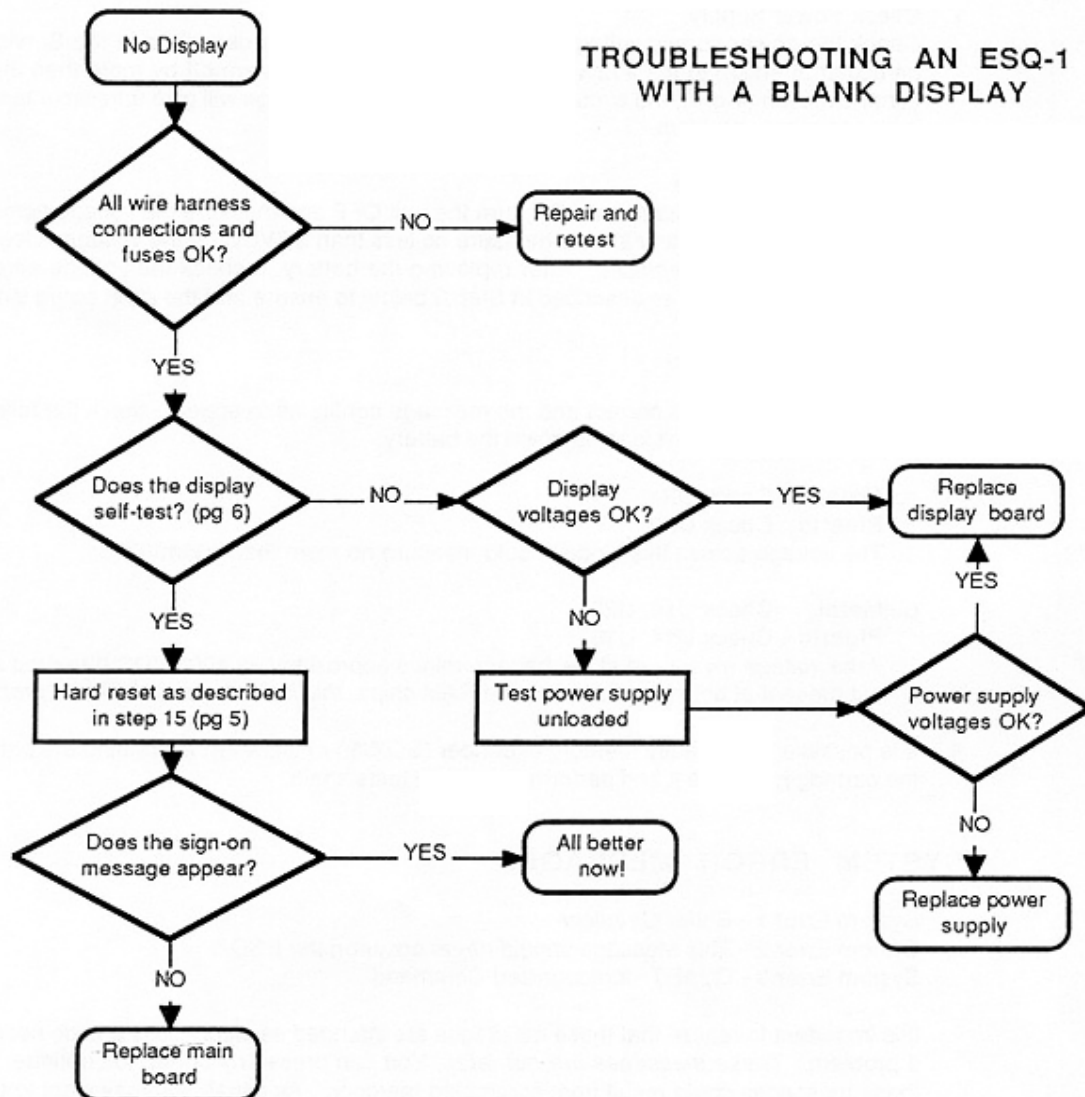

# ESQ SERVICE MANUAL

---

## ***SECTION 2: Metal***

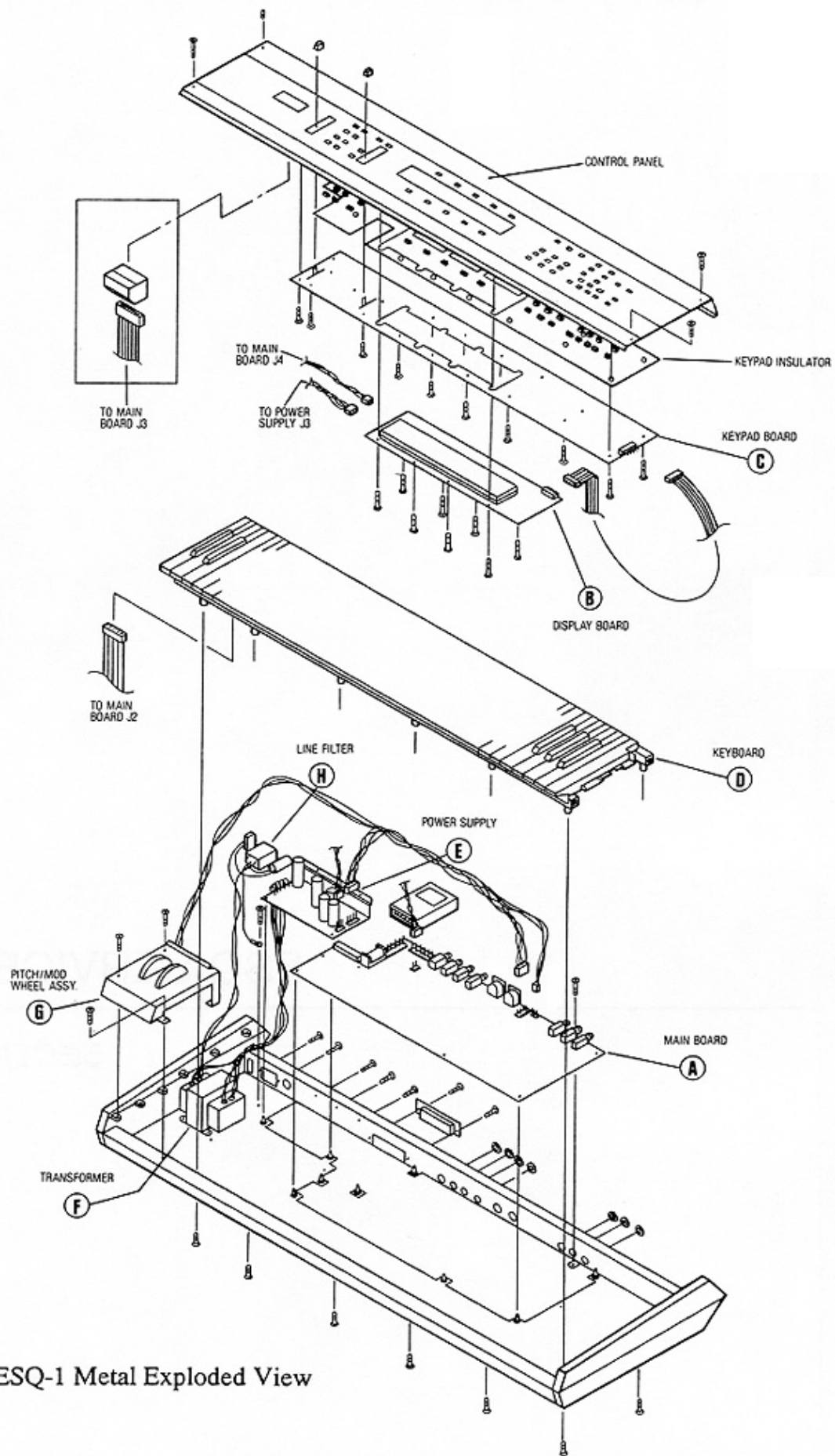

Figure 2 -- ESQ-1 Metal Exploded View



## CHECKING THE POWER SUPPLY

Many ESQ-1 problems may be related to a faulty Power Supply, Transformer or Line Filter. You should check these before trouble-shooting the rest of the unit.

Plug the ESQ-1 in and turn it on. Using a 2.5 mm allen wrench, remove the four screws securing the front panel and raise the panel. Check to make sure that all the connections are secure and correct. After the ESQ-1 has warmed up for five minutes, begin to test the voltages at the points shown in Figures 3 and 4. If the voltages vary outside the allowable limits, follow the procedure described under Testing the Power Supply Unloaded (see page 15), before replacing it.

## TRANSFORMER AND POWER SUPPLY VOLTAGE CHECK POINTS

The proper AC Line Voltage for each ESQ-1 should be printed on the top of the Transformer. Figure 3 shows the check points for reading the AC Line Voltage. Figure 4 shows the connector terminal numbers and correct voltage values for the Power Supply and Transformer. It is normal for Line Voltage to vary +/- 10%.

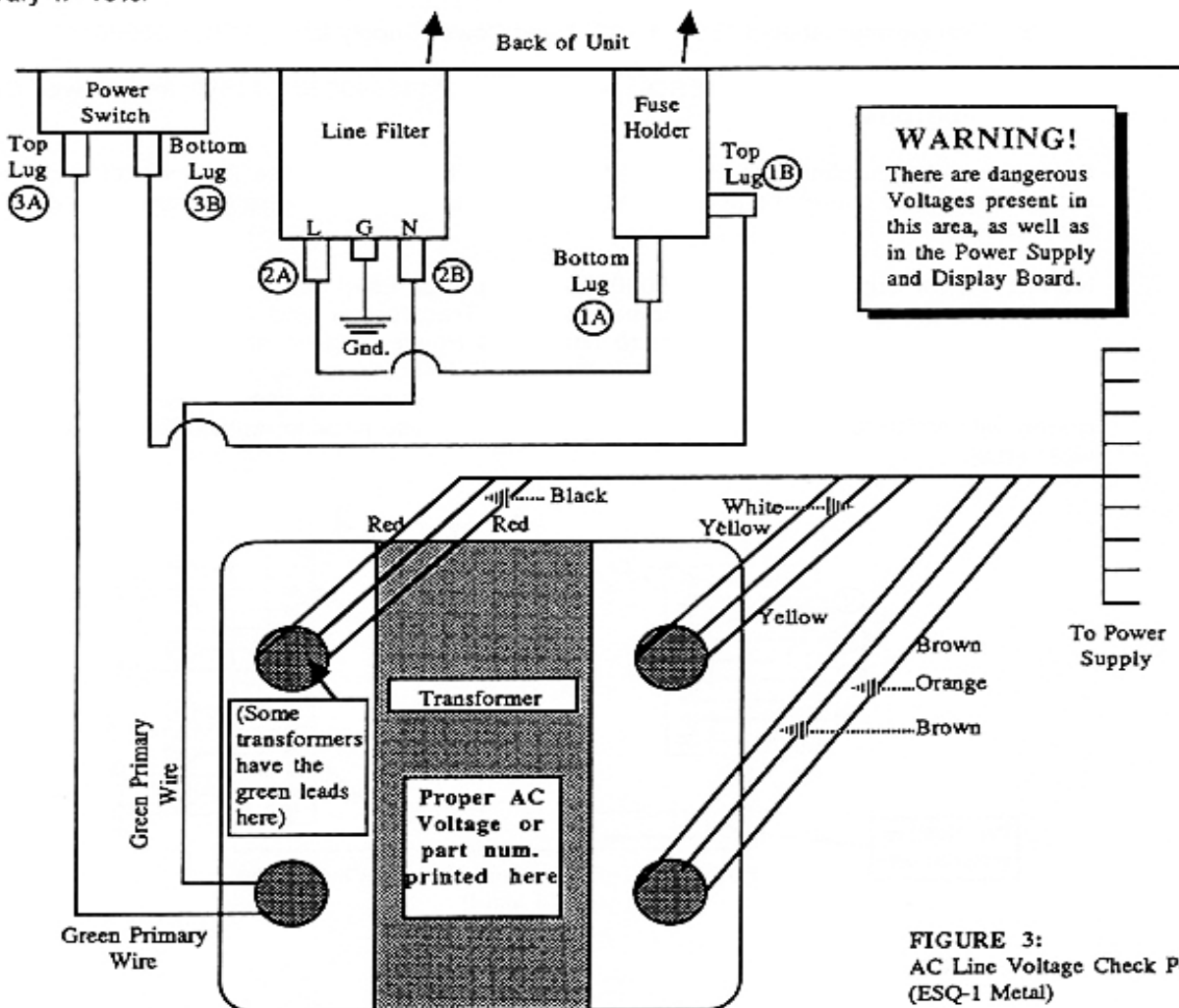

AC LINE VOLTAGE MEASUREMENTS (See Fig. 3)	
With the power switch OFF, the proper AC Line Voltage should read from: 2B-1A, 2B-2A, 2B-3B	With the power switch ON, the proper AC Line Voltage should read from: 2B-1A, 2B-1B, 2B-3B, 2B-3A There should be no voltage across the power switch.

## POWER SUPPLY MEASUREMENTS

On ESQ-1 systems designed for 115 VAC (US) operation, there are three different Power Supply/Transformer configurations. These configurations are denoted by both the label on the top of the Transformer and the part number silk-screened on the lower left of the Power Supply PC board. The three configurations are:

- A. Transformer labeled "EA 001" and Power Supply labeled "4001004201".
- B. Transformer labeled "ESQ-1 120V" and Power Supply labeled "4001005601".
- C. Transformer labeled "ESQ-1 -110V-R" or "1450000301 115V" and Power Supply labeled "4001004201".

If you suspect a problem with the Power Supply and the labels on the Transformer and Power Supply do not correspond to one of the above configurations, contact the Ensoniq Customer Service Department for instructions.

**NOTE:** Power Supplies labeled "4001005601" are to be used ONLY with Transformers labeled "ESQ-1 120V". To prevent improper combinations, the Transformer and PC board are keyed. *Under no circumstances* should you attempt to connect a Power Supply labeled "4001005601" to any other Transformer, nor should you connect "ESQ-1 120V" Transformers to any other Power Supply. Problems with over or under-voltage will occur if improper combinations are used. If you need to replace a Power Supply with a different number Power Supply, you may also need to replace the Transformer as well (and vice versa).

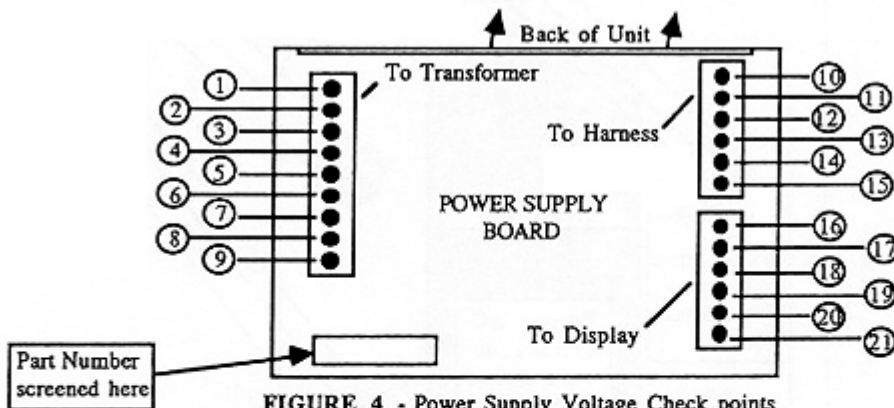

FIGURE 4 - Power Supply Voltage Check points (ESQ-1 Metal)

The following chart lists the voltage ranges for proper operation of each supply (fully loaded) and the appropriate terminals to read across with the voltmeter (refer to Figure 4 for terminal locations):

<u>Designation</u>	<u>Terminals</u>		<u>-----Allowable range-----</u>			<u>Units</u>
	<u>+</u>	<u>-</u>	<u>A</u>	<u>B</u>	<u>C</u>	
Digital Supply	1	3	13.5 to 16.5	12.5 to 15.5	15 to 19	VACrms
Analog Supply	4	6	22.5 to 28	21.5 to 26.5	23 to 29.5	VACrms
Display Filament	7	9	8.5 to 10.5	8 to 10	8.5 to 11	VACrms
+5 Digital	11	10	+4.8 to +5.25	Same	Same	VDC
+V Unreg	12	10	+8 to +11	Same	Same	VDC
+12 Analog	13	14	+11.7 to +12.6	Same	Same	VDC
Analog GND	10	14	0 (connections are common)	Same	Same	VDC
-12 Analog	15	14	-11.4 to -12.6	Same	Same	VDC
+5 Display	17	16	Same as +5 Digital	Same	Same	
Vbb	18	16	+45 to +55	+38 to +48	+45 to +55	VDC
+12 Display	19	16	Same as +12 Analog	Same	Same	
Filament	20	21	Same as Display filament	Same	Same	
Display Offset	20	16	Same as +V Unreg	Same	Same	

### TESTING THE POWER SUPPLY UNLOADED

If the Power Supply readings exceed the indicated tolerance (particularly the +5 Digital line between terminals 10 and 11) it is possible that a defective component on the Main Board is drawing the Power Supply down. In this case you should test the Power Supply unloaded before proceeding. To do so, follow this procedure:

Turn the unit OFF and remove the two connectors on the right side of the Power Supply, leaving only the connector from the Transformer attached. Unloaded, the +5 V line will read considerably higher.

**Power Supplies marked PART NO. 4010005601** can be expected to produce voltages between 13 and 16.5 VDC at the output of the 5 Volt regulator (between terminals 10 and 11). **Power Supplies marked PART NO. 4010004201** can be expected to see voltages between 8.5 and 12 VDC at the output of the 5 Volt regulator (between terminals 10 and 11).

All other voltages should read as in the chart above. If these readings are normal when the supply is unloaded, then a problem with the Main or Display Board is usually indicated.

## HARDWARE NOTES

The following items are hardware trouble spots identified with the hardware of the metal ESQ-1. Being aware of these points can save you time when troubleshooting the unit.

### IMPORTANT:

#### Avoid stripping the End Caps when reclosing the Front Panel

When reclosing the metal ESQ-1's front panel after any repair procedure, it is possible to strip out the holes in the plastic end caps by tightening the screws too tight. To avoid this (and thus avoid having to replace the end caps):

- 1) Before closing the lid, put a drop of Super Glue or other heavy-duty adhesive, such as LOCTITE Quick Gel, in the four screw holes in the end caps.
- 2) Install the four screws that hold the front cover, tightening only until the lid is securely closed, but no further. When the glue sets, the screws will hold the cover tightly in place.

#### 1. Shorting Leads

Leads on the bottom side of the Keypad board can occasionally short to components on the Display Board, causing the display and/or the Keypad to behave erratically. If the display functions properly when physically separated from the case lid, but not when bolted down, this is most likely the problem. A cardboard insulator is now being installed between these two boards at the factory to prevent this problem. If you suspect this shorting of the Keypad board is the problem, install the insulator between the boards when re-assembling the unit.

**Note:** Leads from the switches on the Keypad Board can be carefully trimmed to prevent this shorting problem. Due to the risk of fracturing their more delicate solder joints, however, the leads from the jumpers on that board **should not** be trimmed.

#### 2. Loose Sequencer Expander

The Sequencer Expander Cartridge may work its way loose and cause some of the pins to lose their contact with the connector. This is true particularly in some earlier metal units. This situation will definitely cause the ESQ-1's memory to become scrambled and/or erased and can create the appearance of a serious breakdown. If the Sequencer Expander Cartridge appears to be loose, apply a small piece of double-sided tape to the bottom of the cartridge, re-install it and press down so that the cartridge sticks firmly to the case. The unit should be re-initialized any time this cartridge has been removed and/or inserted.

#### 3. Loose EPROMs

On a few metal units, the Operating System EPROMs (U17 and U18) have come loose from their sockets. This will obviously cause a total shutdown of the unit. Again, a small piece of double-sided tape applied to the underside of the EPROMs upon re-insertion should prevent this. The unit should be re-initialized after re-inserting the EPROMs.

#### 4. Loose screws

In some earlier metal units, there have been instances of screws vibrating out of their holes. Lock washers were installed at the factory on all screws that hold the Keyboard, Display board and Keypad board in place. If one of the Display or Keypad board screws works itself loose, it could fall into the Main board and cause shorting. First check to see that all screws are in place. If one or more of the screws has worked itself loose, it should be re-installed with a lock washer. A dab of medium-strength LOCTITE or fingernail polish applied to the threads upon re-insertion will help keep a loose screw in place.

## 5. Intermittent Start-up Problems

The purpose of this circuit board modification is to eliminate intermittent start up problems, such as no display and loss of sequencer and/or sound data. This update should be performed on any metal ESQ-1 exhibiting this problem with a serial number less than 25449.

**Important Note:** If the Y1 crystal is an SIU crystal (SIU is clearly printed on one side), it must be replaced. Contact ENSONIQ Customer Service for a replacement crystal.

### INSTALLATION PROCEDURE

- A. Disconnect all cables from the ESQ-1, including the power cable. Remove the four (4) screws that fasten the control panel and raise the panel.
- B. Remove the keyboard according to the instructions found in Section D, ESQ-1 Metal.
- C. You should now have access to the main board. Locate U22 (74LS04) and scrape away the solder mask coating (from about 1/4 inch of the digital ground bus directly across from pin 1 of U22 -- see Figure 5). Tack-solder a 470pf capacitor between pin 1 of U22 and the scraped portion of the ground bus.
- D. Temporarily re-connect the power cable (J11), and the Display cable (J4), and test for proper start-up *BEFORE* replacing the keyboard.
- E. Replace the keyboard as described in Section D, ESQ-1 Metal.
- F. Power up, test the unit, and close the control panel.

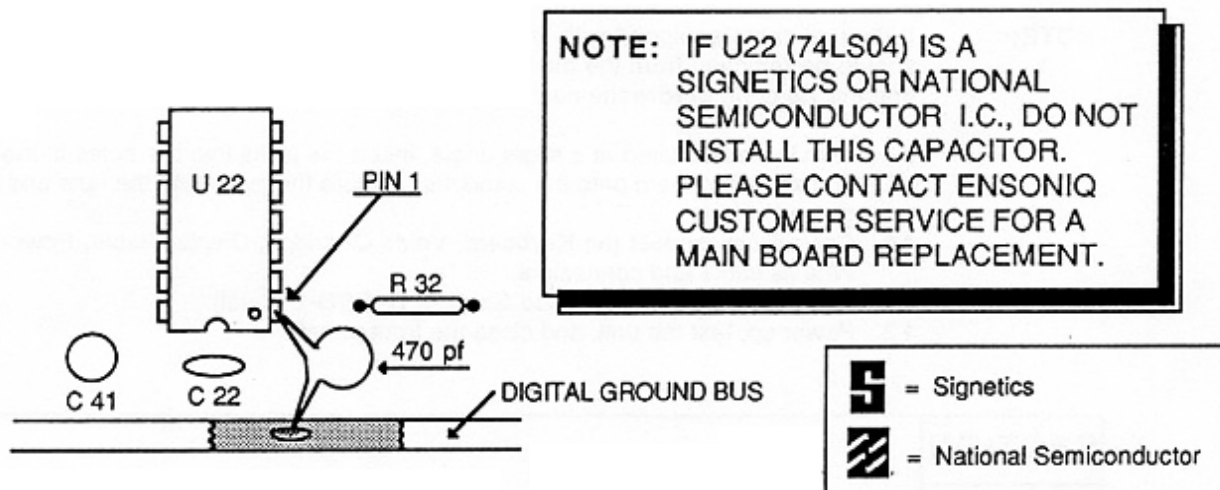

Figure 5

SECTION
---------

A
---

## Replacing the Main Board

1. Remove all cables connected to the ESQ-1, including the Power cable.
2. Remove the four (4) screws that fasten the control panel and raise the panel.
3. Remove the keyboard (see Section D, ESQ-1 Metal).  
**Note:** You should remove the twenty-six (26) pin ribbon cable from Main board (J2) instead of from the keyboard.
4. Remove the seven (7) nuts from the rear panel jacks marked Sustain Ft. Sw., Sequencer Ft. Sw., Tape Out, Tape In, Pedal/VCV, and Left and Right Audio Out.
5. Disconnect the Voice Cartridge connector (J3), the Display cable (J4), the Power cable (J11) and the Wheels cable (J12).
6. Remove the ground screw located near the upper-right corner of the board (between J14 and J15).
7. Pop the board from the five (5) white standoffs by squeezing the standoffs. There are two (2) standoffs near the back of the board that are loose. Save these standoffs for installation in the new board. **Do Not** remove the release film from the adhesive pads of the standoffs.
8. Before installing the new circuit board, make sure the cardboard board insulator is in place. Insert the non-adhesive standoffs on the new board.

**NOTE:** If the unit came equipped with an SQX-10 or SQX-20 Sequencer Expander Cartridge, it should be removed from the old board and installed on the new one. It is recommended that this be done **before** the new board is fastened down.

9. With the board tilted at a slight angle, insert the jacks into the holes in the rear panel and snap the board onto the standoffs. Secure the jacks with the nuts and replace the ground screw.
10. Carefully reconnect the Keyboard, Voice Cartridge, Display cable, Power cable and Wheels cable and connectors.
11. Re-install the Keyboard (see Section D, ESQ-1 Metal).
12. Power up, test the unit, and close the front panel.

SECTION
---------

B
---

## Replacing the Display Board

1. Remove all cables connected to the ESQ-1, including the Power cable.
2. Remove the four (4) screws that fasten the control panel and raise the panel.
3. Remove the six-wire and four-wire cable harnesses located on the left side of the Display board. **Note** that they are keyed.
4. Remove the twenty (20) pin ribbon cable from the Display Board, paying particular attention to the polarity.

**IMPORTANT!** Due to the variety of voltages that are required for the operation of the Display, reversing any of the connectors to the Display Board will damage components on the board. The six-wire and four-wire harnesses are keyed to prevent this. The ribbon cable is **NOT** keyed,

however, and it must be re-installed in the same way it was removed. If the +12 volts that this cable carries is reversed, the voltage may be applied to data lines on the display processor, resulting in the processor's untimely demise.

5. Remove the eight (8) screws which hold the Display board in place.
6. Install a new Display board and replace the eight screws.
7. Re-connect the wire harnesses and the ribbon cable.
8. Power up, test the unit, and close the front panel.

---

<b>SECTION</b>
----------------

<b>C</b>
----------

## Replacing the Keypad Board

1. Remove the Display Board. (Follow steps 1-5 in Section B, ESQ-1 Metal).
2. Remove the Volume and Data Entry knobs.
- IMPORTANT!** 3. The individual colored buttons are held in place only by the Keypad circuit board. To prevent them from falling out when the board is removed, open the control panel all the way and tilt the unit back by placing a 3" block under the front edge of the unit.
4. Remove the nineteen (19) screws that hold the Keypad in place and remove the Keypad.
5. Replace with a new Keypad, and replace the nineteen (19) screws that hold it in place.

**NOTE:** Before you replace the Keypad board, be sure to re-insert the two small plastic cups that fit between the Data Entry and Volume sliders and the inside of the case. To insure a proper fit, first insert the cups into the holes in the case and then insert the slider shafts through the cups.

6. Re-install the Display board, and re-connect the wire harnesses and ribbon cable, paying attention to polarity. Re-install the knobs on the Data Entry and Volume sliders.
7. Power up, test the unit, and close the front panel.

---

<b>SECTION</b>
----------------

<b>D</b>
----------

## Replacing the Keyboard

1. Remove all cables connected to the ESQ-1, including the Power cable.
2. Remove the four (4) screws that fasten the control panel and raise the panel.
3. Place the unit upside down on a soft surface.
4. Remove the ten (10) screws that hold the Keyboard in place.
5. Disconnect the twenty-six (26) pin ribbon connector from underneath the Keyboard, paying particular attention to the polarity.
6. Remove the Keyboard from the case.
7. Connect the twenty-six (26) pin ribbon cable to the new Keyboard, and place it in the unit.
8. Replace the screws that hold the Keyboard in place.
9. Power up, test the unit, and close the front panel.

---

**SECTION****E****Replacing the Power Supply**

1. Remove all cables connected to the ESQ-1, including the Power cable.
2. Remove the four (4) screws that fasten the control panel, and raise the panel.
3. Disconnect the cable assemblies from the Main Board, the Display Board, and the Transformer. These connectors are keyed and have connector locks.

**IMPORTANT!** If the replacement supply has a different Part Number than the original, it will be necessary to replace the Transformer as well. See **POWER SUPPLY MEASUREMENTS-Metal** (page 14) for the listing of compatible Transformers and Power Supplies.

4. The Power supply is held in place by three (3) self-tapping screws inserted from the back panel and two (2) plastic standoffs. Remove the three screws and pull the Power Supply straight up and out while squeezing the standoffs.
5. To replace the Power Supply, first make sure that the insulator pad is in place. Snap the new unit onto the standoffs, making sure they are fully seated. Re-attach the heat sink onto the back panel with the three screws.
6. Re-attach the wire harnesses, paying particular attention to the alignment of pins and connectors.
7. Power up, test the unit, and close the front panel.

---

**SECTION****F****Replacing the Transformer**

The ESQ-1's Transformer is riveted into place at the factory. Replacing it will require drilling out the four (4) rivets and installing the replacement Transformer with the screws and nuts provided.

1. Remove all cables connected to the ESQ-1, including the Power cable.
2. Remove the four (4) screws that fasten the control panel, and raise the panel.
3. Disconnect the Transformer from the Power Supply, Power Switch, and the Line Filter, making a note of the correct polarities.

**NOTE!** If the replacement Transformer has a different Part Number than the original, it may be necessary to replace the Power Supply as well. See the section **POWER SUPPLY MEASUREMENTS--Metal** (page 14) for a complete listing of compatible Transformers and Power Supplies.

4. Tilt the unit on its back to expose the four (4) rivet heads on the bottom of the case.
5. Using a 3/16" drill bit, carefully drill the four (4) rivets until the heads fall off. You should support the Transformer while drilling the last rivet to prevent its dropping out and possibly damaging something. Check to make sure that no fragments of the rivets or the four washers are left in the case.
6. Install the new Transformer using the four (4) screws and nuts supplied, making sure to insert the bolts in from the bottom of the unit and to use the lock washers on the inside.
7. Re-connect the Transformer cables.
8. Power up, test the unit, and close the front panel.



---

<b>SECTION</b>
----------------

<b>G</b>
----------

## Replacing the Pitch/Mod Wheel Assembly

The Pitch and Mod Wheels are replaced as an assembly, along with the Pitch/Mod Wheel panel and cable harness. Care should be given to properly aligning the panel to the front of the ESQ-1 case.

1. Remove all cables connected to the ESQ-1, including the power cable.
2. Remove the four (4) screws that fasten the control panel and raise the panel.
3. Remove the Keyboard as described in Section D, ESQ-1 Metal.
4. Remove the top side screw that attaches the Pitch/Mod Wheel housing to the case via an "L" shaped tab (directly beneath the lowest key of the keyboard.)
5. Remove the two (2) hex screws on the top left side of the assembly.
6. Tilt the unit on its back and remove the two (2) remaining screws that hold the housing in place.
7. Cut the wire ties that hold the wire harness in place and disconnect the harness from the main board (J12).
8. Connect the new Pitch/Mod Wheel wire harness and align the housing with the screw holes. Replace the three screws that hold it in place.
9. Replace the keyboard (see Section D, ESQ-1 Metal).
10. Power up, test the unit, and close the front panel.

---

<b>SECTION</b>
----------------

<b>H</b>
----------

## Replacing the Line Filter

1. Remove all cables connected to the ESQ-1, including the Power cable.
2. Remove the four (4) screws that fasten the control panel and raise the panel.
3. Remove the three (3) wire tabs connected to the back of the Filter, paying particular attention to polarity.
4. Remove the two (2) screws and nuts that secure the Filter to the case. Note that there are lock washers on both the inside and the outside.
5. Install the new Line Filter from inside the case and reconnect the wires to the Filter, again noting the proper polarity.

**IMPORTANT!** Failure to connect the wires to their proper posts can create a shock hazard (see Figure 3, ESQ-1 Metal).

6. Power up, test the unit, and close the front panel.

SECTION
---------

I
---

## Replacing the Operating System EPROMs

The ESQ-1 operating system can be updated by replacing the OS EPROMs. Each ESQ-1 has two Operating System EPROMs located in the center of the main board. After replacing these EPROMs, the ESQ-1 must be re-initialized and the filters must be tuned. The Sequencer memory is erased during re-initialization, so all sequencer data must be saved before starting this procedure.

1. Remove all cables connected to the ESQ-1, including the Power cable.
2. Remove the four (4) screws that fasten the control panel, and raise the panel.
3. Remove the keyboard (see Section D, ESQ-1 Metal).
4. You will find the two Operating System EPROMs, U17 (OSHI) and U18 (OSLO), located in the center of the Main board. Carefully remove the two EPROMs and insert the replacement EPROMs into their respective sockets. Be sure the notch in both EPROMs is facing towards the front of the ESQ-1.
5. Re-install the keyboard (see Section D, ESQ-1 Metal).
6. Re-initialize the unit (see Step 14, page 5).
7. Tune the filters (see Step 11, page 5).
8. Power up, test the unit, and close the front panel.

# ESQ SERVICE MANUAL

---

## ***SECTION 3: Plastic***

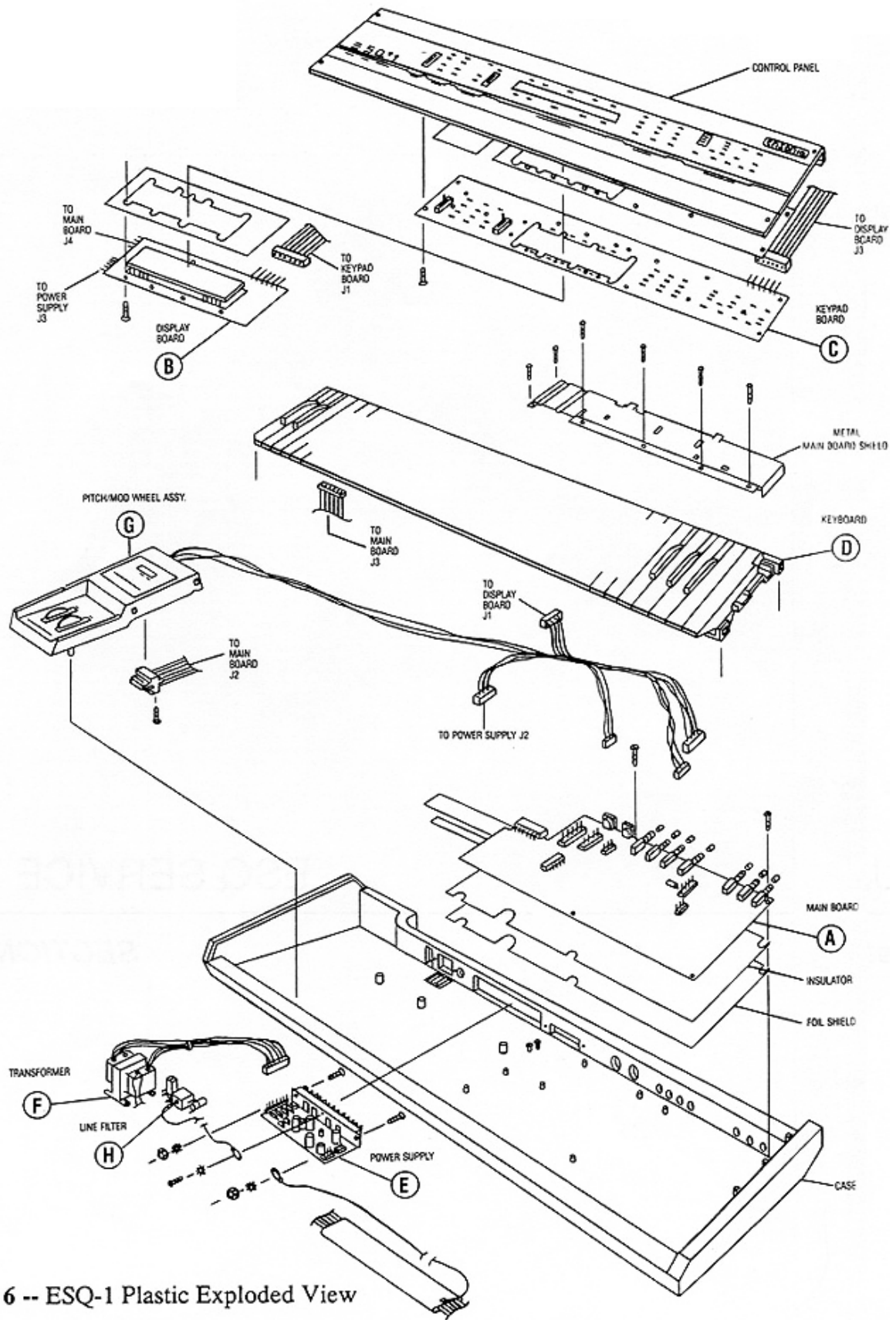

Figure 6 -- ESQ-1 Plastic Exploded View

## CHECKING THE POWER SUPPLY

Many ESQ-1 problems may be related to a faulty Power Supply, Transformer or Line Filter. You should check these before trouble-shooting the rest of the unit.

Plug the ESQ-1 in and turn it on. Using a 2.5 mm allen wrench, remove the four screws securing the front panel and raise the panel. Check to make sure that all the connections are secure and correct. After the ESQ-1 has warmed up for five minutes, begin to test the voltages at the points shown in Figures 7 and 8. If the voltages vary outside the allowable limits, follow the procedure described under Testing the Power Supply Unloaded (see page 27), before replacing it.

## TRANSFORMER AND POWER SUPPLY VOLTAGE CHECK POINTS

The proper AC Line Voltage for each ESQ-1 should be printed on the top of the Transformer. Figure 7 shows the check points for reading the AC Line Voltage. Figure 8 shows the connector terminal numbers and correct voltage values for the Power Supply and Transformer. It is normal for Line Voltage to vary  $\pm 10\%$ .

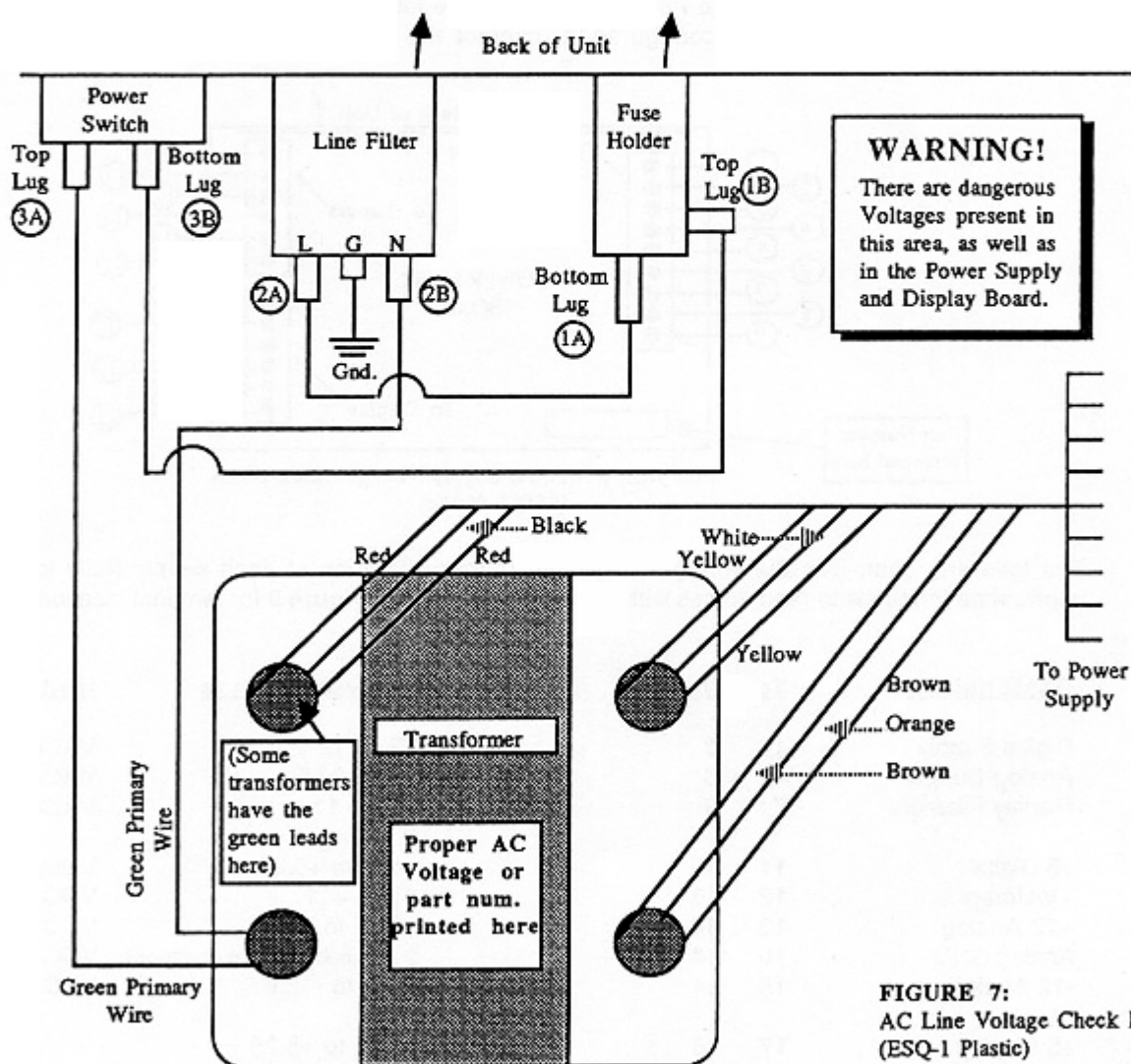

FIGURE 7:  
AC Line Voltage Check Points  
(ESQ-1 Plastic)

AC LINE VOLTAGE MEASUREMENTS (See Fig. 7)	
With the power switch OFF, the proper AC Line Voltage should read from: 2B-1A, 2B-2A, 2B-3B	With the power switch ON, the proper AC Line Voltage should read from: 2B-1A, 2B-1B, 2B-3B, 2B-3A There should be no voltage across the power switch.

## POWER SUPPLY MEASUREMENTS

On plastic ESQ-1 systems designed for 115 VAC (US) operation, there is only one proper Power Supply/Transformer configuration. This configuration is denoted by both the label on the top of the Transformer and the part number silk-screened on the lower left of the Power Supply PC board. The proper Transformer/Power Supply configuration for plastic ESQ-1's is:

Transformer labeled "1450000301 115V" and Power Supply labeled "4001006901"

If you suspect a problem with the Power Supply and the labels on the Transformer and Power Supply do not correspond to the above configuration, contact the Ensoniq Customer Service Department for instructions.

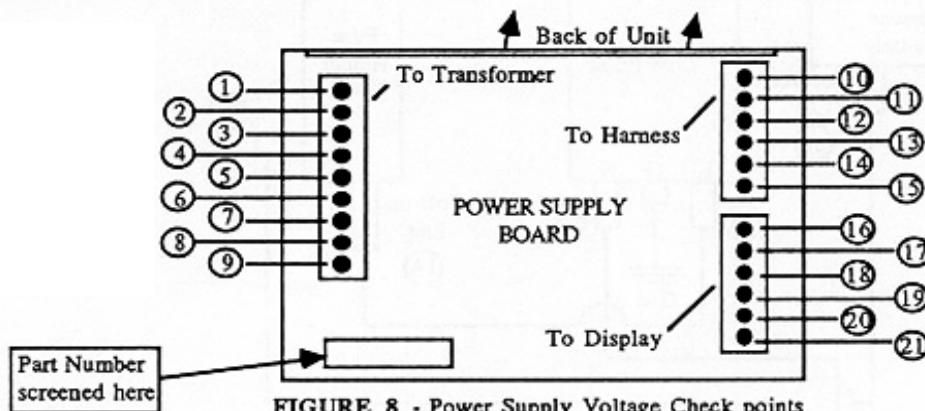

FIGURE 8 - Power Supply Voltage Check points (ESQ-1 Plastic)

The following chart lists the voltage ranges for proper operation of each supply (fully loaded) and the appropriate terminals to read across with the voltmeter (refer to Figure 8 for terminal locations):

Designation	Terminals		Allowable range	Units
	+	-		
Digital Supply	1	3	15 to 19	VACrms
Analog Supply	4	6	23 to 29.5	VACrms
Display Filament	7	9	8.5 to 11	VACrms
+5 Digital	11	10	+4.8 to +5.25	VDC
+V Unreg	12	10	+8 to +11	VDC
+12 Analog	13	14	+11.7 to +12.6	VDC
Analog GND	10	14	0 (connections are common)	VDC
-12 Analog	15	14	-11.4 to -12.6	VDC
+5 Display	17	16	+4.75 to +5.25	VDC
Vbb	18	16	+45 to +55	VDC
+12 Display	19	16	Same as +12 Analog	
Filament	20	21	Same as Display filament	
Display Offset	20	16	Same as +V Unreg	

## TESTING THE POWER SUPPLY UNLOADED

If the Power Supply readings exceed the indicated tolerance (particularly the +5 Digital line between terminals 10 and 11) it is possible that a defective component on the Main Board is drawing the Power Supply down. In this case you should test the Power Supply unloaded before proceeding. To do so, follow this procedure:

Turn the unit OFF and remove the two connectors on the right side of the Power Supply, leaving only the connector from the Transformer attached. Voltages should read as in the chart above. If these readings are normal when the supply is unloaded, then a problem with the Main or Display Board is usually indicated.

## HARDWARE NOTES

---

### 1. **VERY IMPORTANT!! Avoid Stripping Screws**

Because the structural components (Base, Control panel, Wheel cover, and Keyboard Support Rails) are made of plastic, *great care* should be exercised when assembling or disassembling any part of a plastic ESQ-1.

**AVOID OVER-TIGHTENING SCREWS IN THE PLASTIC CASE WHEN EXECUTING THIS OR ANY OTHER REPAIR PROCEDURE!**

When replacing any of the self-tapping screws, it is possible to over-tighten the screws and strip a hole in the case, making it necessary to replace the case or control panel. To keep this from happening, follow these procedures:

- A. Before replacing the screw (or screws), put a drop or two of LOCKTITE or Super Glue Gel into the hole.
- B. Install the screw, tightening only until the sub-assembly being attached is snug against the case. **Do not tighten the screws any further.** When the glue sets, the screws will hold the sub-assembly tightly in place.

---

### 2. **Failures when Writing to STC-8 E<sup>2</sup>PROM Storage Cartridges**

Getting a WRITE FAILED error message while trying to write to an STC-8 cartridge may be caused by Texas Instruments 74ALS244s in position U3 and U4 or Fairchild 74F139s date code 8645 in position U13, U15, and U19. If this is the case, swap the main board.

### 3. **SQX-10s and SQX-20s**

A number of different problems, primarily sequencer related, may occur if the SQX-10 or SQX-20 Sequencer Expander Cartridge is not fully inserted. When debugging a unit with a sequencer expander, test the unit with the expander un-plugged and see if this eliminates the problem. If it does, try reconnecting the expander, making sure it is fully inserted.

A new, stiffer foam is now being used on the ESQ-1 Sequencer Expander Port cover that will not only prevent the SQX-10 or SQX-20 from coming loose, but will also aid in its proper installation. When installing a cartridge with the new foam, it will be positively forced into its proper place. If the cover does not sit flush with the rear panel of the ESQ-1 when it is replaced, the cartridge has not been properly seated in its connector and should be re-installed. This new foam is white and is available from Ensoniq upon request.

### 4. **Intermittent Start-up problems**

The purpose of this circuit modification is to eliminate intermittent start up problems, such as a scrambled or blank display display or loss of sequencer and/or sound data. This update should be performed on any metal or plastic ESQ-1 exhibiting this problem and having a serial number less than 25449.

**NOTE:** If the crystal Y1 is an SIU crystal (SIU is clearly printed on one side), it must be replaced. Contact ENSONIQ Customer Service for a replacement crystal.

**INSTALLATION PROCEDURE**

- A. Remove all cables, including the Power cable, from the ESQ-1. Remove the four (4) screws that fasten the control panel and raise the control panel.
- B. Remove the keyboard as described in Section D ESQ-1 Plastic.
- C. Do not remove the Main board from the unit. Locate U1 (74LS04). Directly across from pin 1 of U1, scrape the solder mask coating from an area about 1/4 inch square on the digital ground bus (see Figure 9). Tack-solder a 470pf capacitor between pin 1 of U1 and the scraped area of the ground bus.
- D. Temporarily reconnect the Power cable (J11) and the Display cable (J4) and test for proper start-up *BEFORE* replacing the keyboard and shield.
- E. Replace the keyboard as described in Section D, ESQ-1 Plastic.
- F. Power up, test the unit and close the control panel.

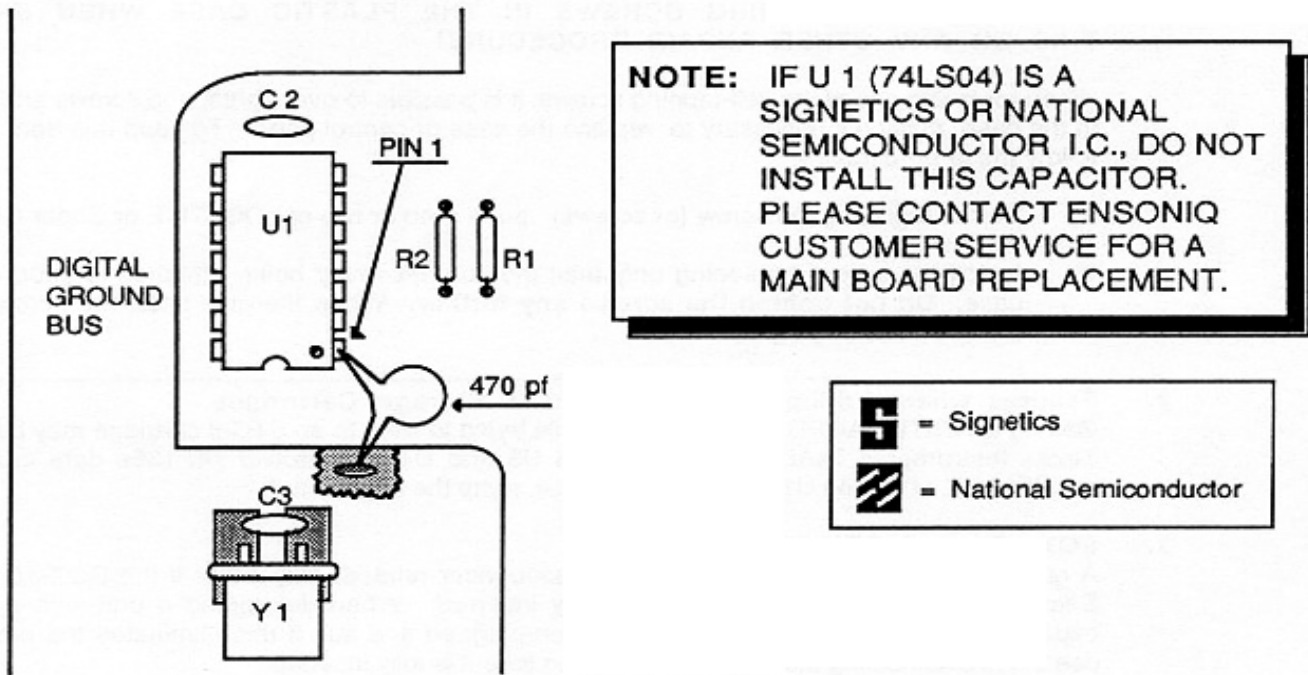

Figure 9



---

**SECTION****A****Replacing the Main Board**

1. Remove all cables connected to the ESQ-1, including the Power cable.
2. Remove the four (4) screws that fasten the control panel and raise the panel.
3. Remove the Keyboard and metal Main board shield (see **Section D** of ESQ-1 Plastic). Note that you should remove the twenty-six (26) pin ribbon cable from the Main Board (at J3) instead of from the keyboard.
4. Remove the seven (7) nuts from the rear panel jacks marked Sustain Ft. Sw., Sequencer Ft. Sw., Tape Out, Tape In, Pedal/CV, Left/Mono and Right Audio Out.
5. Remove the Program Cartridge cable (J2) from the Main board. Remove the nine (9) screws from the Main board.
6. Before installing the new circuit board, make sure the cardboard insulator is in place.

**NOTE:**

If the unit came equipped with an SQX-10 or SQX-20 Sequencer Expander Cartridge, it should be removed from the old board and installed on the new one. It is recommended that this be done **before** the new board is fastened down.

7. With the board tilted on a slight angle, insert the jacks into the holes in the rear panel. Press the board down into place.
8. Replace the Main board screws and secure the jacks with the nuts. Connect the Program Cartridge cable and the Keyboard cable.
9. If present, feed the ground wire up through the hole in the metal shield.
10. Re-install the keyboard and metal shield (see **Section D**, ESQ-1 Plastic).
11. Power up, test the unit, and close the front panel.

---

**SECTION****B****Replacing the Display Board**

1. Remove all cables connected to the ESQ-1, including the Power cable.
2. Remove the four (4) screws that fasten the control panel and raise the panel.
3. Remove the six-wire and four-wire cable harnesses located on the left side of the Display board. **Note** that they are keyed.
4. Remove the twenty (20) pin ribbon cable from the Display board, paying particular attention to the polarity.

**IMPORTANT!** Due to the variety of voltages that are required for the operation of the Display, reversing any of the connectors to the Display board will damage components on the board. The six-wire and four-wire harnesses are keyed to prevent this potential damage. The ribbon cable is **NOT** keyed, and it must be reinstalled the same way it was removed. If the +12 volts that this cable carries is reversed, the voltage may be applied to data lines on the display processor, resulting in the processor's untimely demise.

5. Remove the eight (8) screws which hold the Display board in place.
6. As a part of the re-assembly, make sure the cardboard insulators in place. Install the new board using the eight screws.
7. Re-connect the wire harnesses and the ribbon cable.
8. Power up, test the unit, and close the front panel.

---

**SECTION****C****Replacing the Keypad Board**

1. Follow steps 1-5 in **Section B, ESQ-1 Plastic**.
2. Remove the Volume and the Data Entry knobs. Remove the Display board insulator, making sure to note its position.

**IMPORTANT!**

3. The individual colored buttons are held in place only by the Keypad board and the insulator. To prevent them from falling out when the board is removed, make sure the control panel is open all the way.
4. Remove the twenty-one (21) screws that hold the Keypad in place and remove the Keypad.
5. To re-assemble, first make sure that the insulator and all the buttons are in place. Make sure that the eight (8) display lens retainers are in the proper position and that the lens is clean.
6. Install the new Keypad board using the twenty-one (21) screws. Re-install the Display board insulator and then re-install the Display board. Re-connect the wire harnesses and ribbon cable, paying attention to polarity. Re-install the knobs on the Data Entry and Volume sliders.
7. Power up, test the unit, and close the front panel

---

**SECTION****D****Replacing the Keyboard**

Two keyboards are now being used: one with the connector on the left end of the keyboard and the other with the connector on the the middle of the keyboard. Please inform Customer Service which keyboard you have to ensure that you are shipped the correct replacement keyboard and/or cable.

Left End Connector : use long keyboard cable

Middle Connector: use short keyboard cable

1. Remove all cables connected to the **ESQ-1**, including the Power cable.
2. Remove the four (4) screws that secure the control panel and raise the panel.
3. Remove the six (6) screws that fasten the metal Main board shield to the case and keyboard frame. Disconnect the Display cable (**J4**), the Power cable (**J11**), and the Pitch/Mod Wheel cable (**J12**) from the Main board. Remove the metal shield from the unit.
4. Place the unit upside down on a soft surface and remove the ten (10) screws that attach the keyboard to the case. See **Figure 10** for location of screws.
5. Carefully turn the unit right side up. Raise the control panel and disconnect the Keyboard Ribbon cable (**J3**) from the Main board, paying particular attention to the polarity.
6. Remove the keyboard from the case by gently lifting up the front of it while pulling it toward the front of the unit. Once the rear of the keyboard has cleared the control panel mounting tabs, the keyboard can be removed from the keyboard cavity.

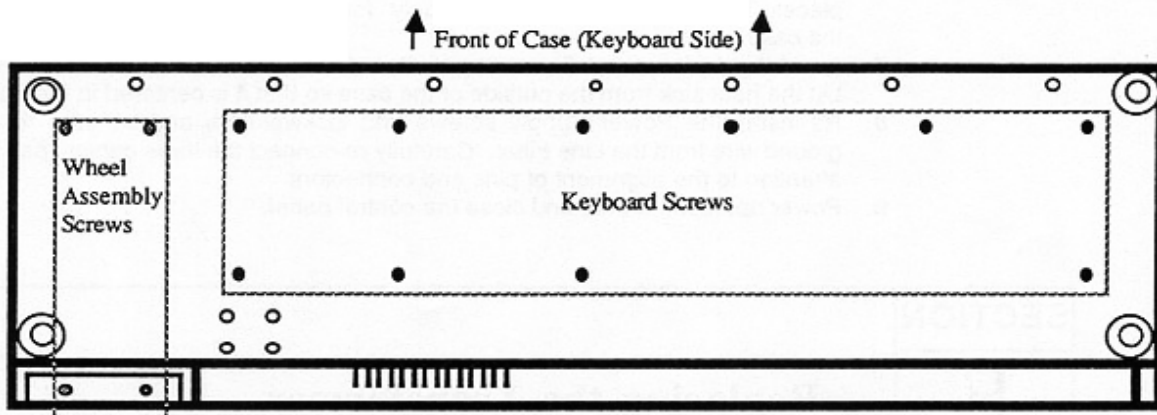

**FIGURE 10--Bottom of  
ESQ-1 Plastic Case**

7. Making note of the proper polarity, remove the Keyboard Ribbon cable from the old keyboard and install it on the new keyboard.
8. Connect the Keyboard Ribbon cable to the Main board. Be sure that the cable lies flat beneath the keyboard and is not pinched under the keyboard frame.
9. Insert the new keyboard rear first into the unit at the front of the keyboard cavity. Gently slide the keyboard toward the rear of the unit, lowering the front of the keyboard as needed to clear the control panel mounting tabs.
10. Turn the unit upside down on a soft surface and replace the ten (10) screws that secure the keyboard to the case.
11. While replacing the metal shield, if present feed the spade lug end of the ground wire through the opening in the shield. Install the spade lug to the screw directly across from the opening on the shield. Replace the remaining five screws that fasten down the metal shield.
12. Install the metal shield over the Main board and replace the six (6) screws fastening it to the case and keyboard frame.
13. Connect the Display cable, Power cable, and Pitch/Mod Wheel cable to the Main board.
14. Power up, test the unit, and close the control panel.

## SECTION

# E

## Replacing the Power Supply

1. Remove all cables connected to the ESQ-1, including the Power cable.
2. Remove the four (4) screws that fasten the control panel and raise the panel.
3. Disconnect the nine (9) pin connector (J1), the six (6) pin connector (J2), and the four (4) pin connector (J3) from the Power Supply Board. Note that these connectors are keyed.
4. Remove the two (2) screws and nuts that secure the Power Supply to the case. Note that there are lock washers on each screw and a ground wire leading from the Line Filter on the left screw.
5. Remove the Power Supply board by pulling the front of the board toward the keyboard and then lifting it up so that the heat sink clears the case.

6. Before replacing the Power Supply board, first make sure that the insulator pad is in place. The standoffs are intended only for support and should not be stuck down to the case.
7. Insert the replacement Power Supply Board from the inside of the case, heat sink first. Lift the heat sink from the outside of the case so that it is centered in the opening.
8. Re-install the Power Supply screws and lockwashers and be sure to connect the ground wire from the Line Filter. Carefully re-connect the three cables, paying particular attention to the alignment of pins and connectors.
9. Power up, test the unit, and close the control panel.

---

**SECTION****F****Replacing the Transformer**

Due to problems that may occur with the plastic case, all units that need the Transformer replaced should be sent back to the factory. Contact your distributor if you are outside the U.S.

---

**SECTION****G****Replacing the Pitch/Mod Wheel Assembly**

The Pitch and Mod Wheels are replaced as an assembly along with the cable harness.

1. Remove all cables connected to the ESQ-1, including the Power cable.
2. Remove the four (4) screws that fasten the control panel and raise the panel.
3. Place the unit upside down on a soft surface and remove the four (4) screws that attach the Wheel Assembly to the case. See Figure 10 for location of screws.
4. Return the unit to an upright position. Cut the wire ties that hold the wire harness in place. Disconnect the harness from the Main board, from the Display board and from the Power Supply (J2). Note that these connectors are keyed and have connector locks. Carefully lift the Wheel Assembly out of the case.
5. Disconnect the cable from the program cartridge, paying particular attention to polarity.
6. Connect the new wire harness to the Main board (J4, J11, J12), to the Display board, and to the Power Supply, paying particular attention to the alignment of pins and connectors. Reconnect the wire harness to the case using wire ties.
7. Re-attach the Wheel Assembly to the case using the four screws.
8. Attach the Program Cartridge cable to the Main board and attach the drain wire to the heat sink of the Power supply.
9. Power up, test the unit, and close the control panel.

---

**SECTION****H****Replacing the Line Filter**

1. Remove all cables connected to the **ESQ-1**, including the Power cable.
2. Remove the four (4) screws that fasten the control panel and raise the panel.
3. Remove the three (3) wire tabs connected to the back of the Filter, paying particular attention to polarity.
4. Remove the two (2) screws and nuts that secure the Filter to the case. Note that there are lock washers on the inside only.
5. To replace the Line Filter, first make sure that the foil shield is in place. Install the new Line Filter from the outside of the case. The foil shield should make contact with the bottom of the new Line Filter.
6. Re-connect the three wires to the Filter, again noting the proper polarity.

**IMPORTANT!** Failure to connect the wires to their proper posts can lead to a potential shock hazard (see Figure 7).

7. Power up, test the unit, and close the front panel.

---

**SECTION****I****Replacing the Operating System EPROMs**

The **ESQ-1** operating system can be updated by replacing the OS EPROMs. Each **ESQ-1** has two Operating System EPROMs located in the center of the Main board. After replacing these EPROMs, the **ESQ-1** must be re-initialized and the filters must be tuned. The Sequencer memory is erased during re-initialization, so all sequencer data must be saved before starting this procedure.

1. Remove all cables connected to the **ESQ-1**, including the Power cable.
2. Remove the four (4) screws that fasten the control panel and raise the panel.
3. Remove the six (6) screws that fasten the metal Main board shield to the case and keyboard frame. Disconnect the Display cable (J4), the Power cable (J11), and the Pitch/Mod Wheel cable (J12) from the Main board. Remove the metal shield from the unit.
4. The two Operating System EPROMs, U16 (OSHI) and U20 (OSLO), are located in the center of the Main board. Carefully remove the two EPROMs and insert the replacement EPROMs into their respective sockets. Be sure the notch in both EPROMs is facing towards the front of the **ESQ-1**.
5. Power up, re-initialize the system and tune the filters. Test the unit and then close the front panel.

**SECTION****J****Installing Ferrite Bead**

On later plastic ESQ-1's, a ferrite bead was added to the wires from the transformer to the power supply to prevent possible memory loss. All plastic case ESQ-1's with operating system 3.X must have a ferrite bead installed. This is because O.S. 3.X is extremely sensitive to power spikes that may occur. The ferrite bead is used to suppress spikes that might be induced onto the ground plane. Call ENSONIQ Customer Service if you need ferrite beads.

1. Carefully surround the 9 wires from the transformer to the power supply with both ferrite bead halves.
2. Tape both halves in place then use heat shrink tubing to secure the ferrite bead halves together.
3. Be sure to completely enshroud the ferrite bead with the tubing to ensure proper insulation.
4. Use a tyrap to keep the ferrite bead close to the power supply connector (J1).

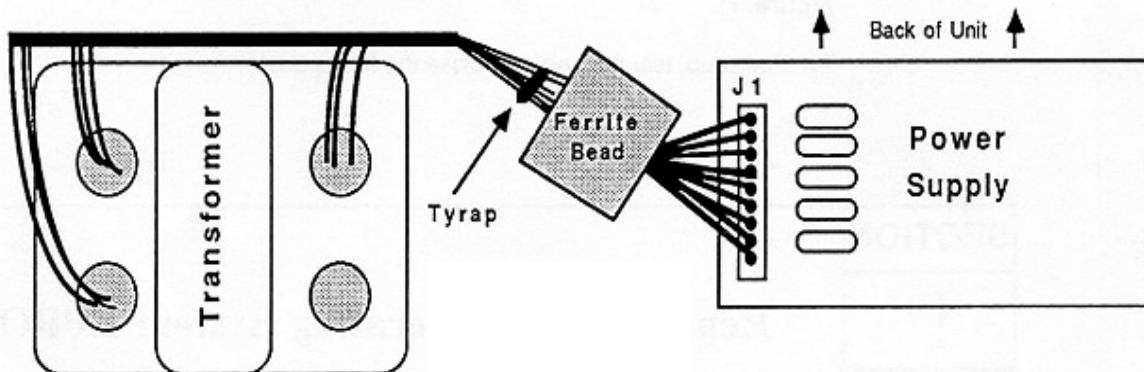

**Figure 10A**  
Ferrite Bead Installation  
ESQ-1 Plastic

# ESQ SERVICE MANUAL

---

## ***SECTION 4: ESQ-M***

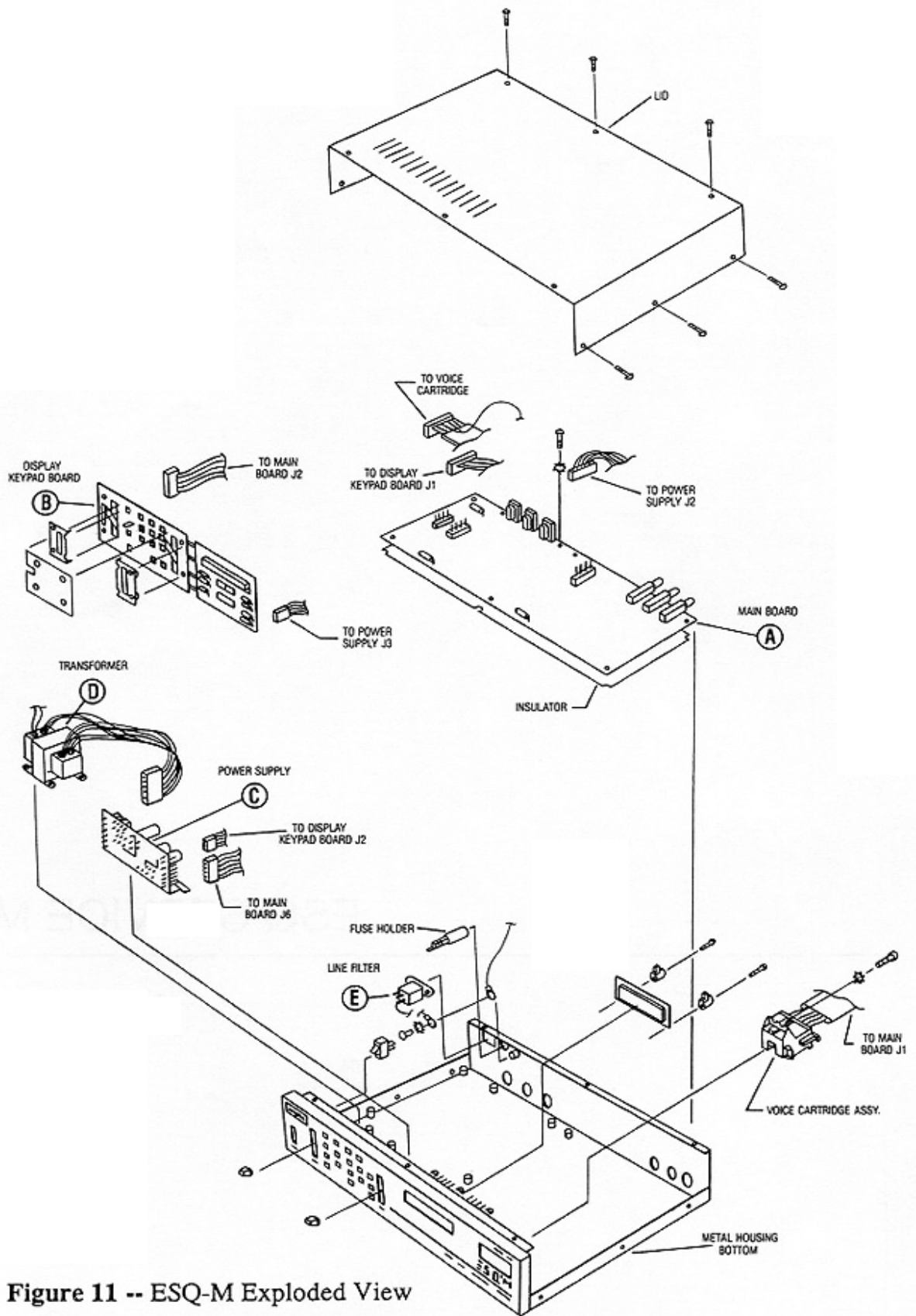

Figure 11 -- ESQ-M Exploded View



## INTERNAL MEMORY

A given ESQ-M is likely to have Program data in its internal memory that is near and dear to the owner of that unit. In the event that it becomes necessary to re-initialize the memory during repairs, it is highly recommended that the internal program memory in the unit be saved to an STC-8 E<sup>2</sup>PROM Storage Cartridge before servicing. See the ESQ-M Musician's Manual for full instructions on saving Program data.

## CHECKING THE POWER SUPPLY

Many ESQ-M problems may be related to a faulty Power Supply, Transformer or Line Filter. You should check these before troubleshooting the rest of the unit.

Plug the ESQ-M in and turn it on. Using a 2.5 mm allen wrench, remove the twelve screws securing the lid and remove it. Check to make sure that all the connections are secure and correct. When the ESQ-M has warmed up for five minutes, begin to test the voltages at the points shown in Figures 12 and 13. If the voltages vary outside the allowable limits, follow the procedure described under Testing the Power Supply Unloaded (see page 38) before replacing it.

## TRANSFORMER AND POWER SUPPLY VOLTAGE CHECK POINTS

Figure 12 shows the check points for reading the AC Line Voltage. Figure 13 shows the connector terminal numbers and correct voltage values for the Power Supply and Transformer. It is normal for Line Voltage to vary +/- 10%.

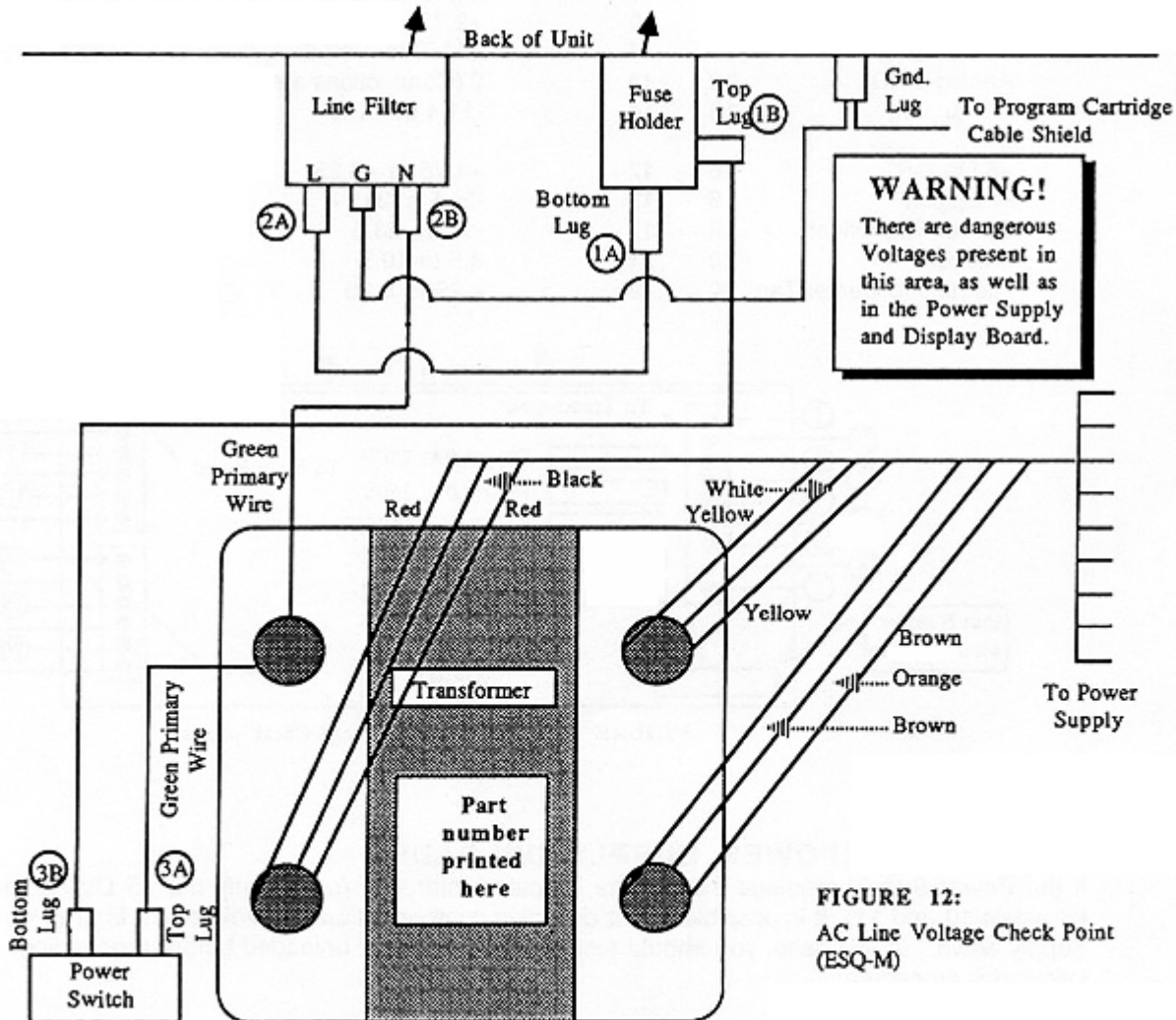

FIGURE 12:  
AC Line Voltage Check Point  
(ESQ-M)

AC LINE VOLTAGE MEASUREMENTS (See Fig.12)	
With the power switch OFF, the proper AC Line Voltage should read from: 2B-1A, 2B-2A, 2B-3B	With the power switch ON, the proper AC Line Voltage should read from: 2B-1A, 2B-1B, 2B-3B, 2B-3A There should be no voltage across the power switch.

### POWER SUPPLY MEASUREMENTS

The following chart lists the voltage ranges for proper operation of each supply (fully loaded) and the appropriate terminals to read across with the voltmeter (refer to Figure 13 for terminal locations):

Designation	Terminals		Allowable range	Units
	+	-		
Digital Supply	1	3	13.5 to 16.5	VACrms
Analog Supply	4	6	22.5 to 28	VACrms
Display Filament	7	9	8.5 to 10.5	VACrms
+5 Digital	11	10	+4.75 to +5.25	VDC
V Reset	12	10	+2.7 to +5.25	VDC
+12 Analog	13	14	+11.7 to +12.6	VDC
Analog GND	10	14	0 (Connections are common)	VDC
-12 Analog	15	14	-11.4 to -12.6	VDC
+5 Display	16	17	+4.75 to +5.25	VDC
-V Display	18	17	-24.5 to -29	VDC
Center Tap Offset	19	17	-18 to -23.5	VDC
Filament	20	21	8.5 to 10.5	VACrms
Filament to Center Tap	20	19	4.25 to 5.25	VACrms

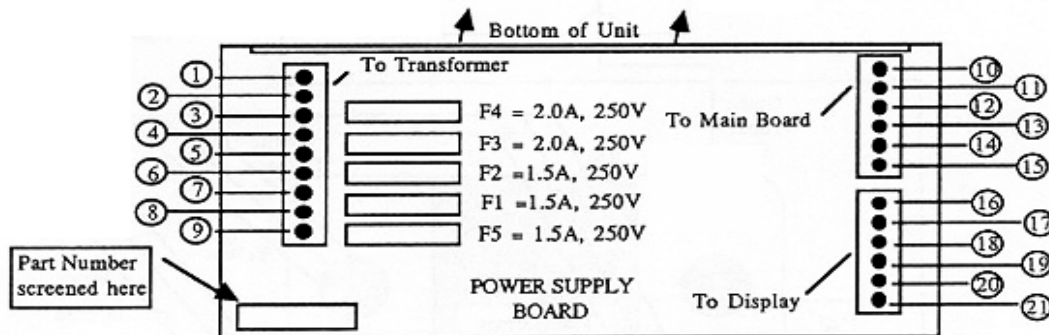

FIGURE 13 Power Supply Voltage Check points (ESQ-M)

### TESTING THE POWER SUPPLY UNLOADED

If the Power Supply readings exceed the indicated tolerance (particularly the +5 Digital line between terminals 10 and 11) it is possible that a defective component on the Main board is drawing the Power Supply down. In this case, you should test the Power Supply unloaded before proceeding. To do so, follow this procedure:

Turn the unit OFF and remove the two connectors on the right side of the Power Supply, leaving only the connector from the Transformer attached. If these readings are normal when the supply is unloaded, a Main or Keypad/Display Board problem is usually indicated.

## **ESQ-M TEST PROCEDURE**

The following procedure will ensure the thorough testing of the **ESQ-M**, and will also aid in trouble-shooting the unit. To perform the following tests you will need a MIDI cable, a Control Voltage (CV) Pedal and an STC-8 E<sup>2</sup>PROM Storage Cartridge. The **ESQ-M** should be connected in Stereo to a sound system.

The **ESQ-M** is heavily software dependent, and certain events can cause the unit to glitch and contract a severe case of amnesia. Sometimes these units merely require re-initialization (see **Step 4** of this test procedure). Since scrambled software can cause problems that at first glance appear to be hardware-related, the use of correlation modules, particularly a known-good Keypad/Display Board, is strongly recommended.

### **1. Getting To The Hidden Functions Page**

- a. Press **Param** and then **Storage**.
- b. While holding down **Scroll**, press **Master**.
- c. The **Scroll** button can now be pressed until the desired function is reached.

### **2. Initial Setup**

- a. Connect MIDI Out of the control keyboard to MIDI In of the **ESQ-M**.
- b. Connect the Left/Mono and Right audio outputs to the headphone amplifier.
- c. Connect a CV Pedal to the **ESQ-M**.

### **3. Keypad Test**

- a. Press **Write**. The display should read **REPLACE EDIT PRG**.
  - b. Press **Param**, then press each of the number buttons **0** through **9** and verify the corresponding pages are displayed. It is necessary to wait for at least two seconds between button presses.
  - c. Press **Program**. The display should show a Track page with a Program selected.
  - d. Press **Scroll**. The track number displayed should be incremented by 1.
  - e. Press **Up Arrow/Yes**. The Program number displayed should be incremented by 1.
  - f. Press **Down Arrow/No**. The Program number displayed should be decremented by 1.
- \* Failure most likely indicates Keypad/Display problems; however, Main Board problems also affect the Keypad/Display function.

### **4. Re-Initialize Unit (Memory Reset)**

- a. Go to the Hidden Functions Page (see **Step 1**).
- b. Select the **MEMORY RESET** page using the **Scroll** button.
- c. While holding **Scroll**, press **Storage**. The display will read **RESET ALL MEMORY**.
- d. Press **Up Arrow/Yes**. The display will show the wake-up screen for two seconds and then return to the Program mode.

### **5. Filter Tune**

- a. Go to the Hidden Functions Page (see **Step 1**).
  - b. Select the **FILTER TUNE** page using the **Scroll** button.
  - c. While holding **Scroll**, press **Storage**. The display will sequence through the eight filters and show a number for each. Verify that each filter number is between 140 and 160.
- \* Failure indicates a Main Board problem.

## 6. Analog Tests

- a. Go to the Hidden Functions Page (see Step 1).
- b. Select the **ANALOG TESTS** page using the **Scroll** button.
- c. While holding **Scroll**, press **Storage**. The display will show the values for the Data Entry Slider (**D=nnn**), the CV Pedal (**P=nnn**) and the Battery (**B=nn**).
- d. Verify that the Data Slider range is from 000 to 255.

**NOTE:** The Data Slider value is updated automatically and may vary by + or - 4 counts.

- e. Verify that the CV Pedal range is from 000 to 255.
- f. Verify that the Battery is 00.
- g. Press **Storage** to exit this function.
- \* **Failure on this page coincides with the part named. Failure could also indicate a Power Supply or a Main board problem. If all the readings are off, the problem is most likely with the Main board.**

## 7. Load From Cartridge Test

- a. Insert a Voice Cartridge.
- b. Select the **Storage** Page (press **Param**, then **Storage**).
- c. Press **Scroll** until the display reads **ST CART A TO INT**.
- d. While holding **Scroll**, press **Storage**. The display will read **COPYING PROGRAMS**.
- e. Remove the Voice Cartridge.
- \* **Failure usually indicates a Main board problem. Check the Cartridge cable, however, to see that it is installed correctly (stripe at pin 1) and that none of the connectors' pins are offset or bent under. (See HARDWARE NOTES on page 41).**

## 8. Write to Cartridge Test

- a. Insert a Test STC-8 Cartridge (not a Voice Cartridge) in the Program Cartridge Slot.
- b. Press **Program**. Verify that all programs (001-120) can be selected by moving the Data Slider. Return to Program Number **001**.
- c. Press **WRITE**. The display should read **REPLACE EDIT PRG**. Press **Up Arrow/Yes**.
- d. Move the Data Slider to change the first letter of the Program Name. Press **Scroll** to move the cursor to the next letter in the Program Name and move the Data Slider to change the next letter.
- e. Press **Scroll** until the Program Number is flashing. Move the Data Slider until the Program Number is **041**.
- f. Press **Write**. The display should read **WRITING PROGRAM** then return with no errors.
- g. Remove the Test STC-8 cartridge.
- \* **Failure usually indicates a Main Board problem. Check the Cartridge cable, however, to see that it is installed correctly (stripe at pin 1) and that none of the connectors' pins are offset or bent under. (See HARDWARE NOTES, page 41).**

## 9. Memory Protect Test

- a. Flip the Power Switch off and on 5 times, allowing the sign-on screen to be displayed each time.
- b. Turn the unit OFF and wait 10 seconds.
- c. Turn the unit ON and verify that the Internal Program Names (Programs 001 to 040) are not scrambled by sequencing through them using the **Up Arrow/Down Arrow** keys.
- \* **Failure to retain internal programs indicates a Main Board problem.**

## 10. Stereo Test

- a. Press **Param**. Press **DCA** then immediately press the **4** button.
- b. Press **Scroll** until the display reads **DCA4 PAN LOC=08**.
- c. Using the Data Slider, move the Pan value to **0** and play more than eight notes. There should only be sound coming from the left channel.
- d. Move the Pan value to **15** and play more than eight notes. There should only be sound coming from the right channel.

- e. Unplug the RIGHT Output Cable and play notes while moving the Pan value up and down. There should not be any variation in the volume of the sound from the left channel.
- f. Set the Pan value back to 08.
- \* Failure indicates a Main Board problem.

#### 11. Sound Test

- a. Select your favorite patch and play.
- b. Test the Volume Slider to see that it adjusts volume.
- \* Failure usually indicates a Main Board or Volume Slider problem.

#### 12. Re-Initialization of Unit

- a. Re-initialize the unit as described in Step 4.
- b. Retune the Filters as described in Step 5.

#### 13. Burn-in Routine

- a. Select the Hidden Functions Page (see Step 1).
- b. Select the ANALOG TESTS page using the Scroll button (see Step 6).
- c. While on this page, a chromatic scale is automatically sent through MIDI Out. To burn-in a unit, simply connect a MIDI cable between MIDI In and MIDI Out.
- d. Verify that the scale is playing.

### SOFTWARE NOTES

The following changes were made to Software version 1.0 and are incorporated in Software version 1.1.

1. When the unit is re-initialized, instead of installing 40 copies of the program called BRASS1, the 40 internal programs are restored to the default factory internal set from ROM.
2. The edit buffer is always replaced by any edit action immediately following system re-initialization. This prevents the occasional problem of having an incorrect program in the edit buffer.

The following change was included in Software version 1.2:

A software change was made to the system initialization routines to eliminate a condition that was found to occur on a relatively small number of units. When the affected unit was re-initialized after being on for a period long enough to reach maximum normal operating temperature, the display would occasionally become scrambled.

### HARDWARE NOTES

The following items are hardware trouble spots identified with the hardware of the ESQ-M. Being aware of these points can save you time when troubleshooting the unit.

#### 1. Write to Cartridge Errors

This problem shows itself in two forms: 1). Getting a WRITE FAILED error message while trying to write to an STC-8 cartridge, or 2). After writing to one position, another position's name is altered (usually position 119). This may be caused by Texas Instruments 74ALS244s in position U1 and U2, or Fairchild 74F139s date code 8645 in position U15 and U18. If either of these parts are in these positions, swap the Main board.

#### 2. No Display

On the first ESQ-M's, star washers were used on all the screws that attached the Keypad/Display Board to the base of the unit. In some cases, the star washer on the screw above the J1 connector can short to a trace underneath it. This will cause the system to crash (a blank display). To remove the star washer on the screw above the J1 connector, first remove the Transformer as described in Section D (see page 43).

**SECTION****A****Replacing the Main Board**

1. Remove all cables connected to the ESQ-M, including the Power cable.
2. Remove the twelve (12) screws that fasten the lid and remove the lid.
4. Remove the three (3) nuts from the rear panel jacks marked Pedal/CV, and Left and Right Audio Out.
5. Disconnect the Voice Cartridge cable (J1), the Keypad/Display cable (J2), and the Power cable (J6). These connectors are keyed and have connector locks.
6. Remove the eight (8) screws which hold down the Main board.
7. Before installing the new Main board, make sure the cardboard insulator is in place.
8. Tilt the new Main board on a slight angle and insert the jacks into the holes in the rear panel. Secure the jacks with the nuts and replace the screws.
9. Carefully reconnect the Voice Cartridge, Keypad/Display and Power cables, paying particular attention to the alignment of pins and connectors.
10. Power up, test the unit, and replace the lid.

**SECTION****B****Replacing the Keypad/Display Board**

1. Remove all cables connected to the ESQ-M, including the Power cable.
2. Remove the twelve (12) screws that fasten the lid and remove the lid.
3. Remove the ribbon cable and the six-wire cable from the Keypad/Display board.  
**Note** the polarity of the ribbon cable and that the six-wire cable is keyed.

**IMPORTANT!** Due to the variety of voltages that are required for the operation of the Display, reversing any of the connectors to the Keypad/Display board will damage components on the board. The six-wire harness is keyed to prevent this potential damage. The ribbon cable is **NOT** keyed and it must be installed the same way it was removed. If the +12 volts that this cable carries is reversed, the voltage may be applied to data lines on the display processor, resulting in the processor's untimely demise.

4. Remove the Volume and Data Entry slider knobs.
5. If you do not have a right-angle screwdriver, remove the Transformer as described in **Section D** and the Power supply as described in **Section C**.
6. Remove the ten (10) screws which hold the Keypad/Display Board in place.
- IMPORTANT!** 7. The individual buttons are held in place by the Keypad/Display Board insulator. To prevent them from falling out when the board is removed, place the unit on a soft surface with its front panel down.
8. To re-assemble, first make sure that the insulator and all the buttons are in place and that the display lens is clean.
9. Install a new Keypad/Display board and replace the ten screws.
10. Replace the Transformer (**Section D**) and the Power Supply (**Section C**).
11. Re-connect the six-wire cable and the ribbon cable, paying particular attention to polarity.
12. Replace the Volume and Data Entry slider knobs.
13. Power up, test the unit, and replace the lid.

---

**SECTION****C****Replacing the Power Supply**

1. Remove all cables connected to the **ESQ-M**, including the Power cable.
2. Remove the twelve (12) screws that fasten the lid and remove the lid.
3. Disconnect the cables from the Main board (J2), the Display board (J3), and the Transformer (J1). Note that these connectors are keyed and that they have connector locks.
4. The Power supply is held in place by three (3) self-tapping screws inserted from the bottom of the unit. Remove the three screws and remove the Power supply.
5. To replace the Power supply, re-attach the heat sink onto the bottom of the unit with the three screws.
6. Re-attach the cables, paying particular attention to the alignment of pins and connectors.
7. Power up, test the unit, and replace the lid.

---

**SECTION****D****Replacing the Transformer**

1. Remove all cables connected to the **ESQ-M**, including the Power cable.
2. Remove the twelve (12) screws that fasten the lid and remove the lid.
3. Disconnect the Transformer cables from the Power supply, Power switch, and the main fuse, making a note of the correct polarities.
4. Remove the four (4) screws and star washers that attach the Transformer to the base.
5. Install the new Transformer using the four (4) screws.
6. Re-connect the Transformer cables.
7. Power up, test the unit, and replace the lid.

---

**SECTION****E****Replacing the Line Filter**

1. Remove all cables connected to the **ESQ-M**, including the power cable.
2. Remove the twelve (12) screws that fasten the lid and remove the lid.
3. Remove the three (3) wires connected to the tabs on back of the Filter, paying particular attention to polarity.
4. Remove the two (2) screws, nuts and star washers that secure the Filter to the case. Note that there are star washers on both the inside and the outside.
5. Install the new Line Filter from inside the case and reconnect the three (3) wires to the Filter, again noting the proper polarity.

**IMPORTANT!** Failure to connect the wires to their proper posts can lead to a potential shock hazard, see **Figure 12**.

6. Power up, test the unit, and replace the lid.

SECTION
---------

F
---

## Replacing the Operating System EPROM

The ESQ-M operating system can be updated by replacing the OS EPROM. Each ESQ-M has one Operating System EPROM located near the center of the Main board. After replacing this EPROM, the ESQ-M must be re-initialized as described in Step 4 and the Filters should be tuned as described in Step 5 of the ESQ-M Test Procedure.

1. Remove all cables connected to the ESQ-M, including the Power cable.
2. Remove the twelve (12) screws that fasten the lid and remove the lid.
3. You will find the Operating System EPROM, U14, located in the center of the Main board. Carefully remove the EPROM and insert the replacement EPROM into its sockets. Be sure the notch in the EPROM is facing towards the front of the ESQ-M.
4. Re-initialize the unit and tune the Filters (Step 4 and 5 of the ESQ-M Test Procedure).
5. Power up, test the unit, and replace the lid.



The Technology That Performs™

In the US: 155 Great Valley Parkway • Malvern, Pennsylvania 19355  
Parts Ordering 1-800-441-1003

In Canada: Kaysound Imports, Inc.  
6969 Trans Canada Highway • Suite 105 • St. Laurent, Canada H4T1V4  
Parts Ordering 514-331-8420