

# KORG®

## PROGRAMMABLE POLYPHONIC SYNTHESIZER MODULE **EX-8000**



# ***SERVICE MANUAL***

### CONTENTS

1. SPECIFICATIONS .....	1
2. MIDI IMPLEMENTATION .....	2
3. STRUCTURAL DIAGRAM .....	11
4. BLOCK DIAGRAM .....	14
5. CIRCUIT DIAGRAM .....	15
6. P.C. BOARD .....	24
7. CIRCUIT DESCRIPTIONS .....	32
8. ADJUSTMENT PROCEDURES .....	40
9. PARTS LIST .....	42

**KORG INC.  
TOKYO/JAPAN**

# 1. SPECIFICATIONS

- Voice 8 voice
- OSC1 Octave (16', 8', 4'), Waveform (1 ~ 16), Level adjustment
- OSC2 Octave (16', 8', 4'), Waveform (1 ~ 16), Interval (Unison, Minor 3rd, Major 3rd, Perfect 4th, Perfect 5th), Detune (25 cents MAX), Level adjustment
- Auto bend Select (OFF, OSC1, OSC2, Both), Mode (UP/DOWN), Time, Intensity
- Noise Level adjustment (White noise)
- VCF Cutoff frequency, Resonance, Keyboard track (0, 1/4, 1/2, 1), EG polarity ( / \ , \ / ), EG intensity
- VCF EG Attack time, Decay time, Breakpoint level, Slope time, Sustain level, Release time, Velocity sensitivity
- VCA EG Attack time, Decay time, Breakpoint level, Slope time, Sustain level, Release time, Velocity sensitivity
- MG Waveform ( ^ , \ , / , □ ), Frequency, Delay time, OSC intensity, VCF intensity
- Bend Max. OSC bend ( $\pm 1$  octave), VCF bend ON/OFF
- Portamento Portamento time
- Digital delay Time (approx. 4 ~ 512ms), Factor (x0.5 ~ 1.0), Feedback level, Modulation frequency (max. 10Hz), Modulation intensity, Effect level
- After touch OSC MG, VCF, VCA
- Key assign mode POLY 1, POLY 2, UNISON 1, UNISON 2
- MIDI Receive channel (ch 1 ~ 16), ENABLE (NOTE DATA/ALL), OMNI (ON/OFF), Arpeggio clock, Key window bottom, Key window top, MIDI data transfer
- Volume (0 ~ max.)
- Tune  $\pm 50$  cents, tone switch
- Programmer PROGRAM/PARAMETER switches, Number select buttons (1 ~ 8), WRITE switch, BANK HOLD switch
- Display Program number, Parameter number, Parameter value
- Tape interface Save, Load, Verify, Cancel
- Input jacks FROM TAPE (HIGH/LOW)
- Output jacks Output (R, L/MONO, HIGH/LOW), PHONES, TO TAPE
- Tape switch ENABLE/DISABLE
- Write switch ENABLE/DISABLE
- MIDI jacks IN, OUT, THRU
- Power consumption 31W
- Power supply Local voltage
- Weight 7.5kg
- Dimensions 430(W) x 412.5(D) x 90(H)mm
- Accessories AC power cord, Connection cord, Data cassette, Program card, Rack Mount Adapter

## 2. MIDI IMPLEMENTATION

### 1. TRANSMITTED DATA

#### 1. Channel messages

##### (a) PROGRAM CHANGE

STATUS	SECOND	THIRD	DESCRIPTION
1 1 0 0    n n n n	0 p p p    p p p p	_____	PROGRAM CHANGE ppppppp = 0 - 63

★ nnnn = 0 ~ 15: channel number specified by parameter 84.

NOTE: 1. PROGRAM NUMBER (0ppppppp) correspond to DISPLAY NUMBER on the PANEL which will be the following:

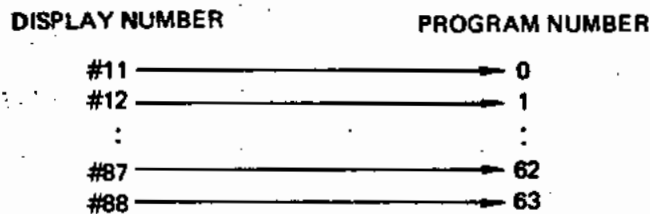

#### 2. System exclusive messages

##### (a) DEVICE ID

BYTE	DESCRIPTION
1 1 1 1    0 0 0 0	EXCLUSIVE STATUS
0 1 0 0    0 0 1 0	KORG    ID 42H
0 0 1 1    n n n n	FORMAT ID 3•H (• = ch)
0 0 0 0    0 0 1 1	EX-8000 ID 03H
1 1 1 1    0 1 1 1	EOX

★ nnnn = 0 ~ 15: channel number (channel provisions within System Exclusive Messages) specified by parameter 84.

NOTE: 2. If DEVICE ID REQUEST, DEVICE ID message will be sent.

##### (b) DEVICE ID REQUEST

BYTE	DESCRIPTION
1 1 1 1    0 0 0 0	EXCLUSIVE STATUS
0 1 0 0    0 0 1 0	KORG    ID 42H
0 1 0 0    n n n n	FORMAT ID 4•H (• = ch) (NOTE 6)
1 1 1 1    0 1 1 1	EOX

★ nnnn = 0 ~ 15: channel number (channel provisions within System Exclusive Messages) specified by parameter 84.

##### (c) DATA DUMP

BYTE	DESCRIPTION
1 1 1 1    0 0 0 0	EXCLUSIVE STATUS
0 1 0 0    0 0 1 0	KORG    ID 42H
0 0 1 1    n n n n	FORMAT ID 3•H (• = ch)
0 0 0 0    0 0 1 1	EX-8000 ID 03H
0 1 0 0    0 0 0 0	DATA DUMP 40H
0 v v v    v v v v	DATA 51 BYTES (See EX-8000 BIT MAP)
⋮	
0 v v v    v v v v	
1 1 1 1    0 1 1 1	EOX

★ nnnn = 0 ~ 15: channel number (channel provision within System Exclusive Messages) specified by parameter 84.

NOTE: 3. If DATA DUMP REQUEST is received, DATA DUMP will be sent.

(d) DATA DUMP REQUEST

BYTE	DESCRIPTION
1 1 1 1 0 0 0 0	EXCLUSIVE STATUS
0 1 0 0 0 0 1 0	KORG ID 42H
0 0 1 1 n n n n	FORMAT ID 3-H (* = ch) (NOTE 6)
0 0 0 0 0 0 1 1	EX-8000 ID 03H
0 0 0 1 0 0 0 0	DATA SAVE REQUEST 10H
1 1 1 1 0 1 1 1	EOX

\* nnnn = 0 ~ 15: channel number (channel provisions within System Exclusive Messages) specified by parameter 84.

(e) WRITE COMPLETED

BYTE	DESCRIPTION
1 1 1 1 0 0 0 0	EXCLUSIVE STATUS
0 1 0 0 0 0 1 0	KORG ID 42H
0 0 1 1 n n n n	FORMAT ID 3-H (* = ch) (NOTE 6)
0 0 1 0 0 0 1 1	EX-8000 ID 03H
0 0 0 0 0 0 0 1	WRITE COMPLETED 21H
1 1 1 1 0 1 1 1	EOX

\* nnnn = 0 ~ 15: channel number (channel provisions within System Exclusive Messages) specified by parameter 84.

NOTE: 4. If WRITE REQUEST is received and program write is completed, a WRITE COMPLETED message will be sent.

(f) WRITER ERROR

BYTE	DESCRIPTION
1 1 1 1 0 0 0 0	EXCLUSIVE STATUS
0 1 0 0 0 0 1 0	KORG ID 42H
0 0 1 1 n n n n	FORMAT ID 3-H (* = ch) (NOTE 6)
0 0 0 0 0 0 1 1	EX-8000 ID 03H
0 0 1 0 0 0 1 0	WRITE ERROR 22H
1 1 1 1 0 1 1 1	EOX

\* nnnn = 0 ~ 15: channel number (channel provisions within System Exclusive Messages) specified by parameter 84.

NOTE: 5. If WRITE REQUEST is received and program write is not completed (if WRITE DISABLE is chosen on the rear panel), a WRITE ERROR message will be sent.

(g) WRITE REQUEST

BYTE	DESCRIPTION
1 1 1 1 0 0 0 0	EXCLUSIVE STATUS
0 1 0 0 0 0 1 0	KORG ID 42H
0 0 1 1 n n n n	FORMAT ID 3-H (* = ch) (NOTE 6)
0 0 0 0 0 0 1 1	EX-8000 ID 03H
0 0 0 1 0 0 0 1	WRITE REQUEST 11H
0 p p p p p p p	PROGRAM NUMBER (p p p p p p p = 0 - 63)
1 1 1 1 0 1 1 1	EOX

\* nnnn = 0 ~ 15: channel number (channel provisions within System Exclusive Messages) specified by parameter 84.

NOTE: 6. When a Format ID is received, channel numbers set at parameter No. 84 and messages with abnormal numbers are ignored. (Not related to OMNI mode.)

## 2. RECOGNIZED RECEIVE DATA

### 1. Channel messages

STATUS	SECOND	THIRD	DESCRIPTION
1 0 0 0 n n n n	0 k k k k k k k k	0 x x x x x x x x	NOTE OFF (NOTE 1) velocity will be ignored.
1 0 0 1 n n n n	0 k k k k k k k k	0 v v v v v v v v	NOTE ON (NOTE 1) www = 1 - 127 (15 STEPS)
1 0 0 1 n n n n	0 k k k k k k k k	0 0 0 0 0 0 0 0	NOTE OFF (NOTE 1)
1 0 1 1 n n n n	0 0 0 0 0 0 0 1	0 v v v v v x x x	OSC MODULATION (5 BITS RESOLUTION)
1 0 1 1 n n n n	0 0 0 0 0 0 1 0	0 v v v v v x x x	VCF MODULATION (5 BITS RESOLUTION)
1 0 1 1 n n n n	0 0 0 0 0 1 1 1	0 v v v v v v v v	VOLUME (7 BITS RESOLUTION)
1 0 1 1 n n n n	0 1 0 0 0 0 0 0	0 0 0 0 0 0 0 0	DAMPER PEDAL OFF
1 0 1 1 n n n n	0 1 0 0 0 0 0 0	0 1 1 1 1 1 1 1	DAMPER PEDAL ON
1 0 1 1 n n n n	0 1 0 0 0 0 0 1	0 0 0 0 0 0 0 0	PORTAMENTO OFF
1 0 1 1 n n n n	0 1 0 0 0 0 0 1	0 1 1 1 1 1 1 1	PORTAMENTO ON
1 0 1 1 n n n n	0 1 1 1 1 0 1 1	0 0 0 0 0 0 0 0	ALL NOTES OFF
1 0 1 1 n n n n	0 1 1 1 1 1 0 0	0 0 0 0 0 0 0 0	OMNI MODE OFF (ALL NOTES OFF)
1 0 1 1 n n n n	0 1 1 1 1 1 0 1	0 0 0 0 0 0 0 0	OMNI MODE ON (ALL NOTES OFF)
1 0 1 1 n n n n	0 1 1 1 1 1 1 0	0 x x x x x x x x	(ALL NOTES OFF)
1 0 1 1 n n n n	0 1 1 1 1 1 1 1	0 0 0 0 0 0 0 0	(ALL NOTES OFF)
1 1 0 0 n n n n	0 p p p p p p p p	—	PROGRAM CHANGE (NOTE 2)
1 1 0 1 n n n n	0 v v v v v v v x	—	AFTER TOUCH (6 BITS RESOLUTION)
1 1 1 0 n n n n	0 x x x x x x x x	0 b b b b b b b b	PITCH BENDER CHANGE LSB will be ignored. MSB will be recognized. (bbbbbb = 64 : CENTER)

★ nnnn = 0 ~ 15:

Channel number specified by parameter 84. When the mode is OMNI ON, all the data will be received. When the mode is OMNI OFF, only data of the channel designated by the parameter will be received. As to MODE MESSAGE, however, designated channel data only will be received even if the mode is OMNI ON.

NOTES: 1. NOTE NUMBER (0kkkkkkk) = 24 ~ 108. If data outside this range is received, the data will be transposed to the same note on the nearest octave. If keywindow parameter 87 and 88 are specified, the data will be charged accordingly.

2. PROGRAM NUMBER (0ppppppp) = 0 ~ 63. If the data is larger than 63, it will be recognized as a number that has 64 subtracted from it.

### 2. System exclusive messages

(a) DEVICED ID

(e) WRITE COMPLETED

(b) DEVICE ID REQUEST

(f) WRITE ERROR

(c) DATA DUMP

(g) WRITE REQUEST

(d) DATA DUMP REQUEST

The above system exclusive messages are the same as Transmitted Data. Refer to page 2.

(h) PARAMETER CHANGE

BYTE	DESCRIPTION
1 1 1 1, 0 0 0 0	EXCLUSIVE STATUS
0 1 0 0, 0 0 1 0	KORG ID 42H
0 0 1 1, n n n n	FORMAT ID 3·H (* = ch) (NOTE 3)
0 0 0 0, 0 0 1 1	EX-8000 ID 03H
0 1 0 0, 0 0 0 1	PARAMETER CHANGE 41H
0 v v v, v v v v	PARAMETER OFFSET (See EX-8000 BIT MAP)
0 v v v, v v v v	PARAMETER VALUE (See EX-8000 BIT MAP)
1 1 1 1, 0 1 1 1	EOX

3. System real time message

STATUS	DESCRIPTION
1 1 1 1 1 1 1 0	ACTIVE SENSING (440ms)

★ nnnn = 0 ~ 15: channel number (channel provisions within System Exclusive Messages) specified by parameter 84.

NOTE: 3. Messages with channel numbers different from those specified by parameter 84 are ignored. (This has no relation to OMNI mode setting.)

3. EXAMPLES OF SYSTEM EXCLUSIVE MESSAGES USED IN COMMUNICATING WITH OTHER EQUIPMENT

1. Data transmission between EX-8000 and DW-8000

(a) SINGLE PROGRAM LOAD

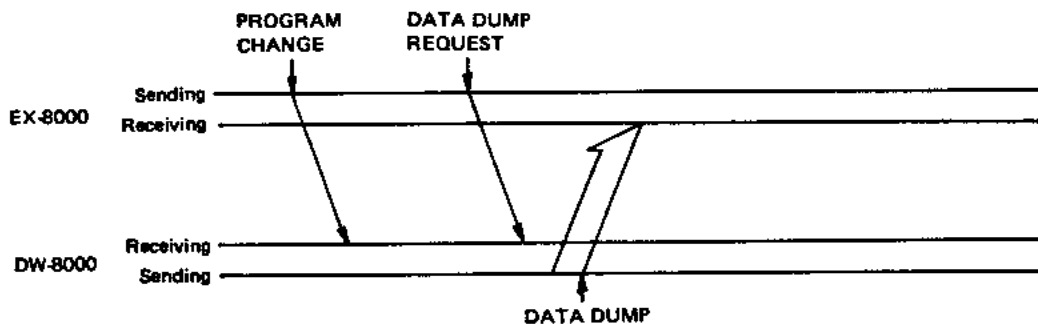

(b) ALL PROGRAM LOAD

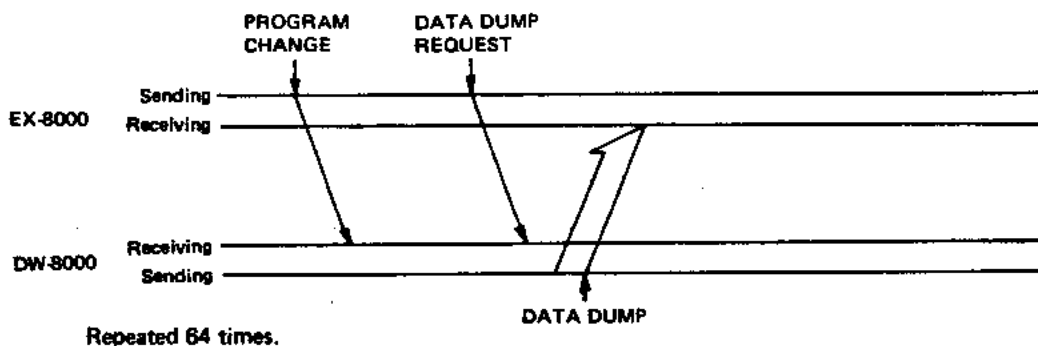

(c) SINGLE PROGRAM SAVE

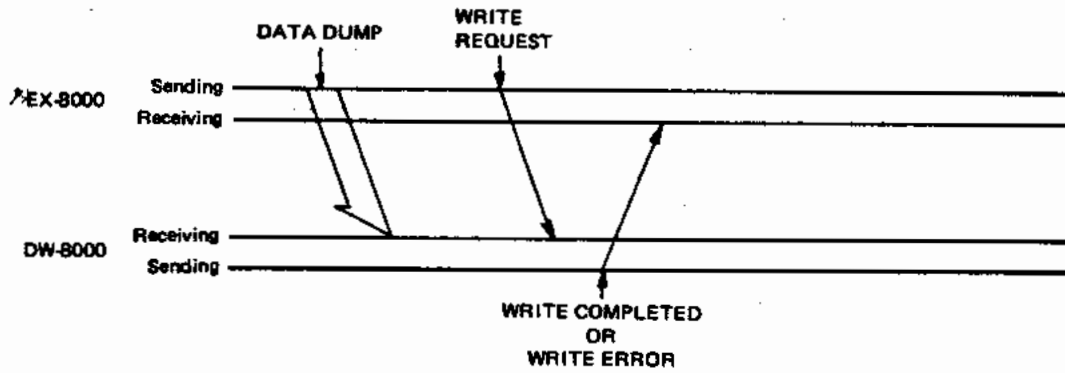

(d) ALL PROGRAM SAVE

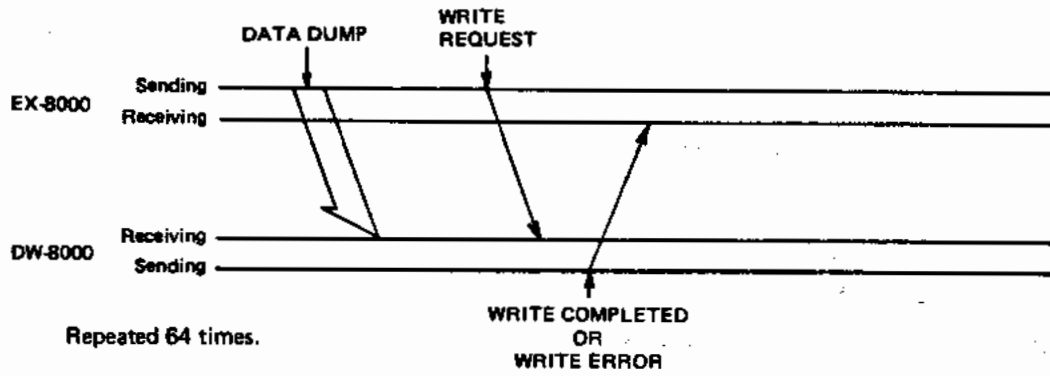

2. Data transmission between EX-8000 and computer.

1. To find the ID number for equipment connected to the computer.

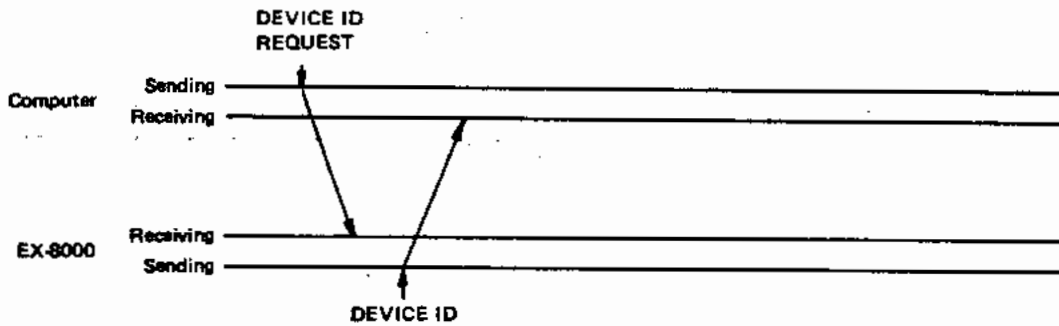

2. To edit sound data within the EX-8000.

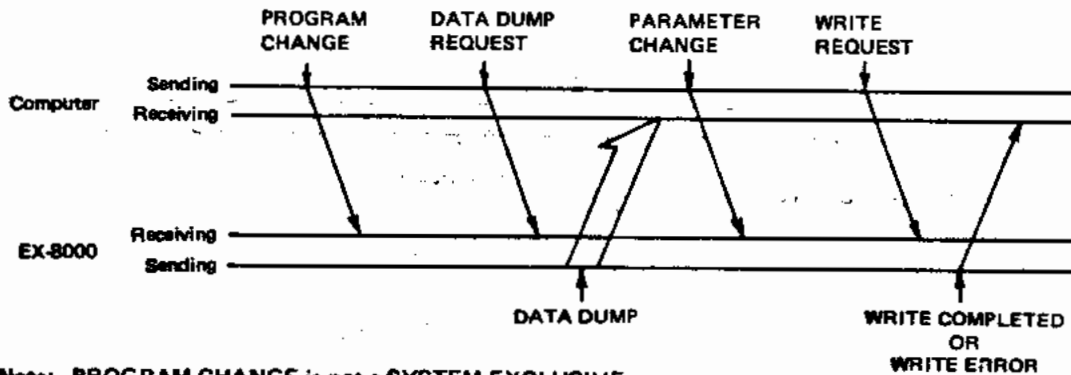

Note: PROGRAM CHANGE is not a SYSTEM EXCLUSIVE message.

3. To edit data already available in the computer.

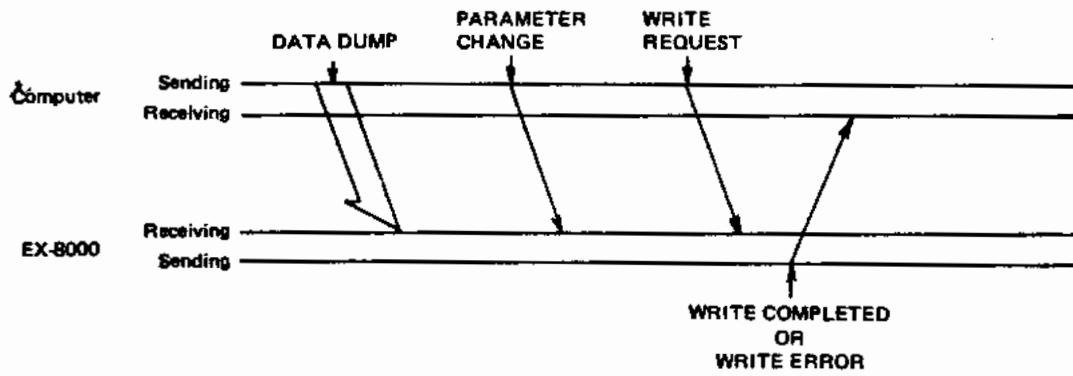

4. To load all 64 sound programs from the computer to the EX-8000.

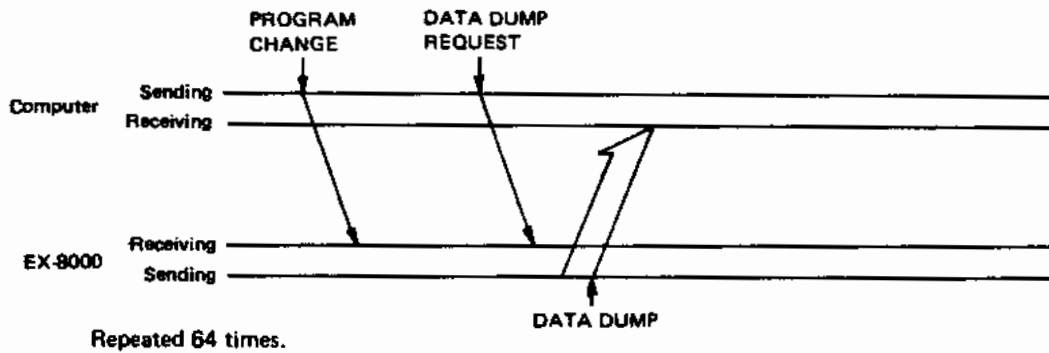

5. To save all 64 sound programs from the EX-8000 to the computer.

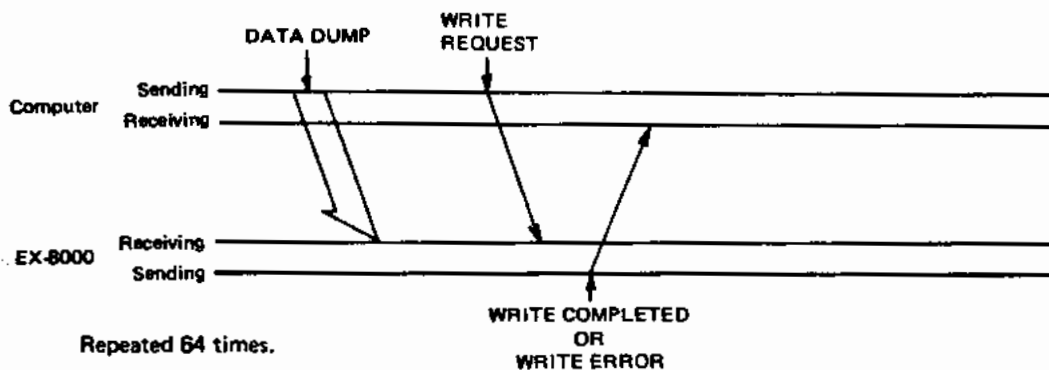



PARAMETER OFFSET	PARAMETER VALUE								
	b7	b6	b5	b4	b3	b2	b1	b0	
38	0	0	0	MG VCF					
38	0	0	0	0	BEND OSC				
40	0	0	0	0	0	0	0	BEND VCF	
41	0	0	0	0	0	DELAY TIME			
42	0	0	0	0	DELAY FACTOR				
43	0	0	0	0	DELAY FEEDBACK				
44	0	0	0	DELAY FREQUENCY					
45	0	0	0	DELAY INTENSITY					
46	0	0	0	0	DELAY EFFECT LEVEL				
47	0	0	0	PORTAMENTO					
48	0	0	0	0	0	0	AFTER T. OSC MG		
49	0	0	0	0	0	0	AFTER T. VCF		
50	0	0	0	0	0	0	AFTER T. VCA		

2. EX-8000 Bit map and corresponding parameter values

PARAMETER NAME	PARAMETER OFFSET	BIT	CORRESPONDING PANEL VALUE	PARAMETER NUMBER
OSC 1 OCTAVE	0	b1 - b0	00 = 16 01 = 8 10 = 4 11 = INHIBIT	11
OSC 1 WAVE FORM	1	b3 - b0	0000 - 1111 = 1 - 16	12
OSC 1 LEVEL	2	b4 - b0	00000 - 11111 = 0 - 31	13
A. B. SELECT	3	b1 - b0	00 = OFF 01 = OSC1 10 = OSC2 11 = BOTH	14
A. B. MODE	4	b0	0 = UP 1 = DOWN	15
A. B. TIME	5	b4 - b0	00000 - 11111 = 0 - 31	16
A. B. INT.	6	b4 - b0	00000 - 11111 = 0 - 31	17
OSC 2 OCTAVE	7	b1 - b0	00 = 16 01 = 8 10 = 4 11 = INHIBIT	21
OSC 2 WAVE FORM	8	b3 - b0	0000 - 1111 = 1 - 16	22
OSC 2 LEVEL	9	b4 - b0	00000 - 11111 = 0 - 31	23
OSC2 INTERVAL	10	b2 - b0	000 = 1 001 = -3 010 = 3 011 = 4 100 = 5 101 - 111 = INHIBIT	24
OSC 2 DETUNE	11	b2 - b0	000 - 110 = 0 - 6 111 = INHIBIT	25
NOISE LEVEL	12	b4 - b0	00000 - 11111 = 0 - 31	26
CUTOFF	15	b5 - b0	000000 - 111111 = 0 - 63	31
RESONANCE	16	b4 - b0	00000 - 11111 = 0 - 31	32
KBD TRACK	17	b1 - b0	00 = 10 01 = 1(1/4) 10 = 2(1/2) 11 = 3(1)	33
POLARITY	18	b0	0 = 1(√) 1 = 2(√)	34
VCF EG INT.	19	b4 - b0	00000 - 11111 = 0 - 31	35
VCF ATTACK	20	b4 - b0	00000 - 11111 = 0 - 31	41
VCF DECAY	21	b4 - b0	00000 - 11111 = 0 - 31	42
VCF BREAK P.	22	b4 - b0	00000 - 11111 = 0 - 31	43

PARAMETER NAME	PARAMETER OFFSET	BIT	CORRESPONDING PANEL VALUE	PARAMETER NUMBER
VCF SLOPE <sup>2</sup>	23	b4 - b0	00000 - 11111 = 0 - 31	44
VCF SUSTAIN	24	b4 - b0	00000 - 11111 = 0 - 31	45
VCF RELEASE	25	b4 - b0	00000 - 11111 = 0 - 31	46
VCF V. SENS	26	b2 - b0	000 - 111 = 0 - 7	47
VCA ATTACK	27	b4 - b0	00000 - 11111 = 0 - 31	51
VCA DECAY	28	b4 - b0	00000 - 11111 = 0 - 31	52
VCA BREAK P.	29	b4 - b0	00000 - 11111 = 0 - 31	53
VCA SLOPE	30	b4 - b0	00000 - 11111 = 0 - 31	54
VCA SUSTAIN	31	b4 - b0	00000 - 11111 = 0 - 31	55
VCA RELEASE	32	b4 - b0	00000 - 11111 = 0 - 31	56
VCA V. SENS	33	b2 - b0	000 - 111 = 0 - 7	57
MG WAVE FORM	34	b1 - b0	0 = 1(∧) 1 = 2(∨) 2 = 3(∟) 3 = 4(└┘)	61
MG FREQUENCY	35	b4 - b0	00000 - 11111 = 0 - 31	62
MG DELAY	36	b4 - b0	00000 - 11111 = 0 - 31	63
MG OSC	37	b4 - b0	00000 - 11111 = 0 - 31	64
MG VCF	38	b4 - b0	00000 - 11111 = 0 - 31	65
BEND OSC	39	b3 - b0	0000 - 1100 = 0 - 12 1101 - 1111 = INHIBIT	66
BEND VCF	40	b0	0 = 0(OFF) 1 = 1(ON)	67
DELAY TIME	41	b2 - b0	000 - 111 = 0 - 7	71
DELAY FACTOR	42	b3 - b0	0000 - 1111 = 0 - 15	72
D. FEEDBACK	43	b3 - b0	0000 - 1111 = 0 - 15	73
D. FREQUENCY	44	b4 - b0	00000 - 11111 = 0 - 31	74
D. INTENSITY	45	b4 - b0	00000 - 11111 = 0 - 31	75
D. EFF. LEVEL	46	b3 - b0	0000 - 1111 = 0 - 15	76
PORTAMENTO	47	b4 - b0	00000 - 11111 = 0 - 31	77
A.T. OSC MG	48	b1 - b0	00 - 11 = 0 - 3	81
AFTER T. VCF	49	b1 - b0	00 - 11 = 0 - 3	82
AFTER T. VCA	50	b1 - b0	00 - 11 = 0 - 3	83

PARAMETER NAME	PARAMETER OFFSET	BIT	CORRESPONDING PANEL DISPLAY/MEMORY
ASSIGN MODE	13	b1 - b0	00 = POLY 1 01 = POLY 2 10 = UNISON 1 11 = UNISON 2
PAR. NO. MEMO.	14	b5 - b0	000000-111110 = 0-62 (7, 14, 15, 21, 22, 23, 31, 39, 47, = INHIBIT)

### 3. STRUCTURAL DIAGRAM

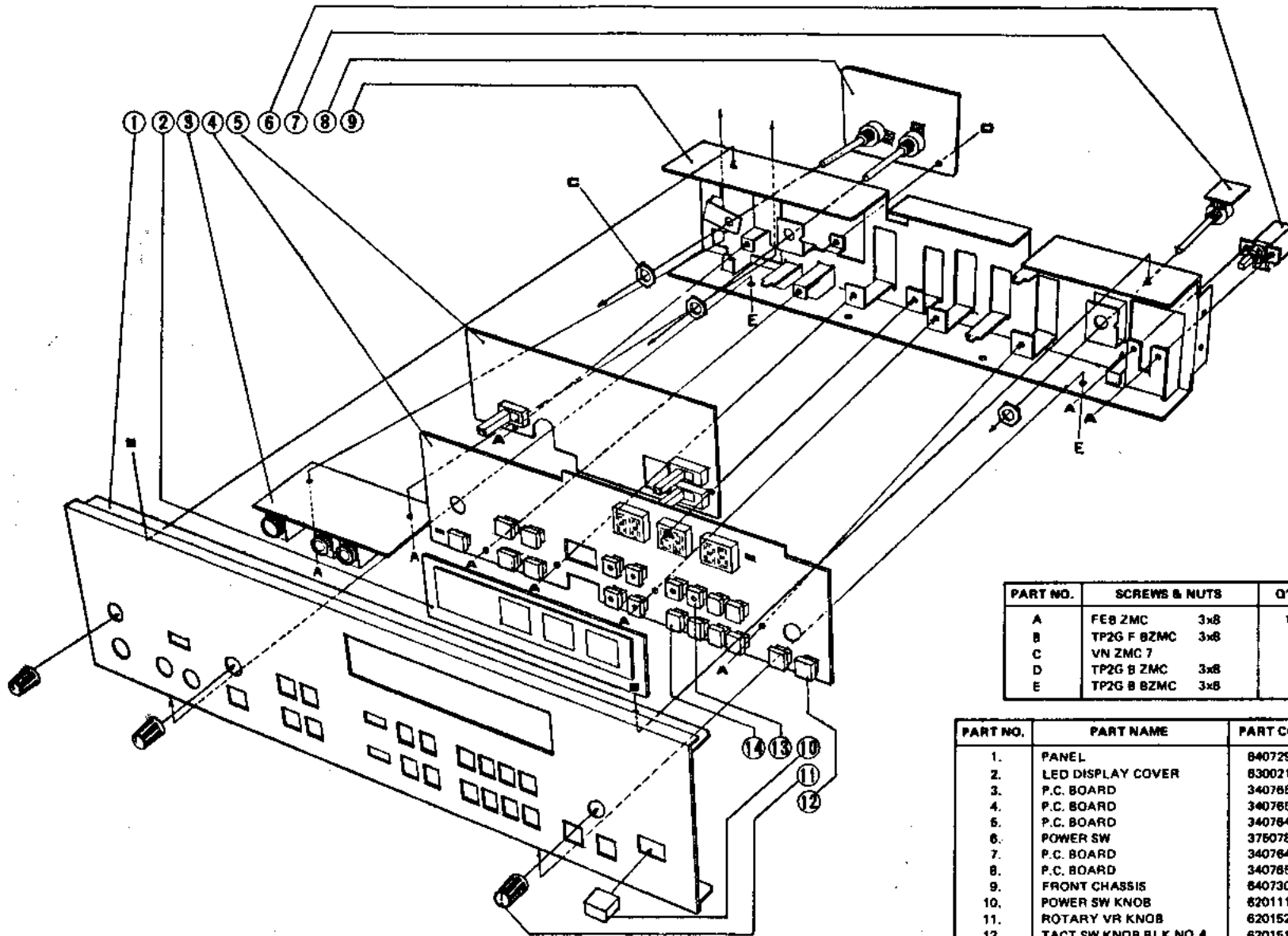

PART NO.	SCREWS & NUTS	Q'TY
A	FE8 ZMC 3x8	10
B	TP2G F 8ZMC 3x8	2
C	VN ZMC 7	3
D	TP2G B ZMC 3x8	1
E	TP2G B 8ZMC 3x8	2

PART NO.	PART NAME	PART CODE
1.	PANEL	84072900
2.	LED DISPLAY COVER	83002100
3.	P.C. BOARD	34076500
4.	P.C. BOARD	34076500
5.	P.C. BOARD	34076400
6.	POWER SW	37507800
7.	P.C. BOARD	34076400
8.	P.C. BOARD	34076500
9.	FRONT CHASSIS	84073000
10.	POWER SW KNOB	62011100
11.	ROTARY VR KNOB	62015200
12.	TACT SW KNOB BLK NO. 4	62016100
13.	TACT SW KNOB KT-8	62011000
14.	TACT SW KNOB RED	62011202

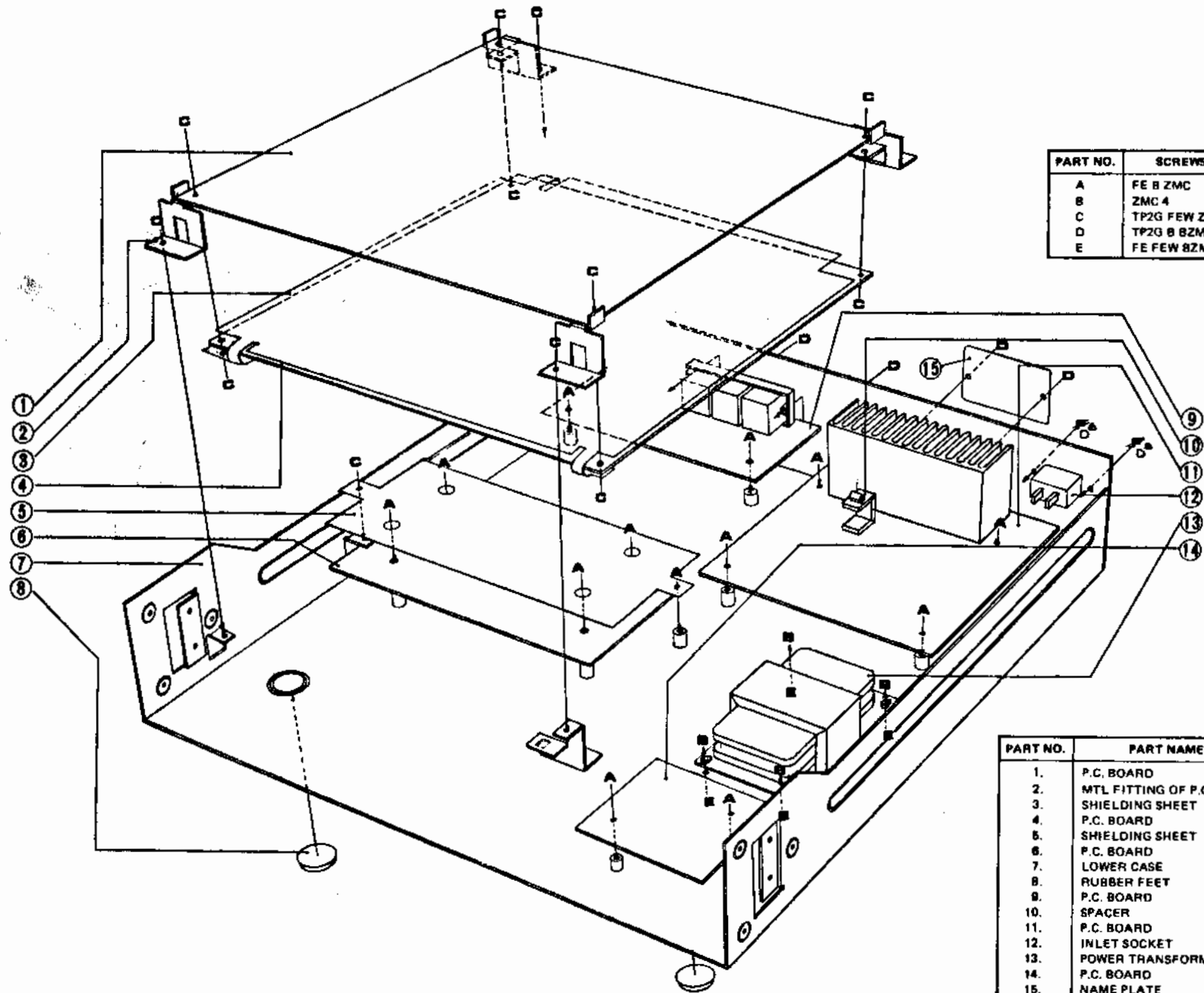

PART NO.	SCREWS & NUTS	Q'TY
A	FE B ZMC 3x8	13
B	ZMC 4	4
C	TP2G FEW ZMC 3x8	11
D	TP2G B BZMC 3x8	6
E	FE FEW BZMC 4x10	4

PART NO.	PART NAME	PART CODE
1.	P.C. BOARD	34086200
2.	MTL FITTING OF P.C. BRD A	64072500
3.	SHIELDING SHEET	63002600
4.	P.C. BOARD	34077100
5.	SHIELDING SHEET	63001600
6.	P.C. BOARD	34077500
7.	LOWER CASE	64073200
8.	RUBBER FEET	50008700
9.	P.C. BOARD	34078400
10.	SPACER	54011600
11.	P.C. BOARD	34078200
12.	INLET SOCKET	54010900
13.	POWER TRANSFORMER	40008200
14.	P.C. BOARD	34078300
15.	NAME PLATE	68800700

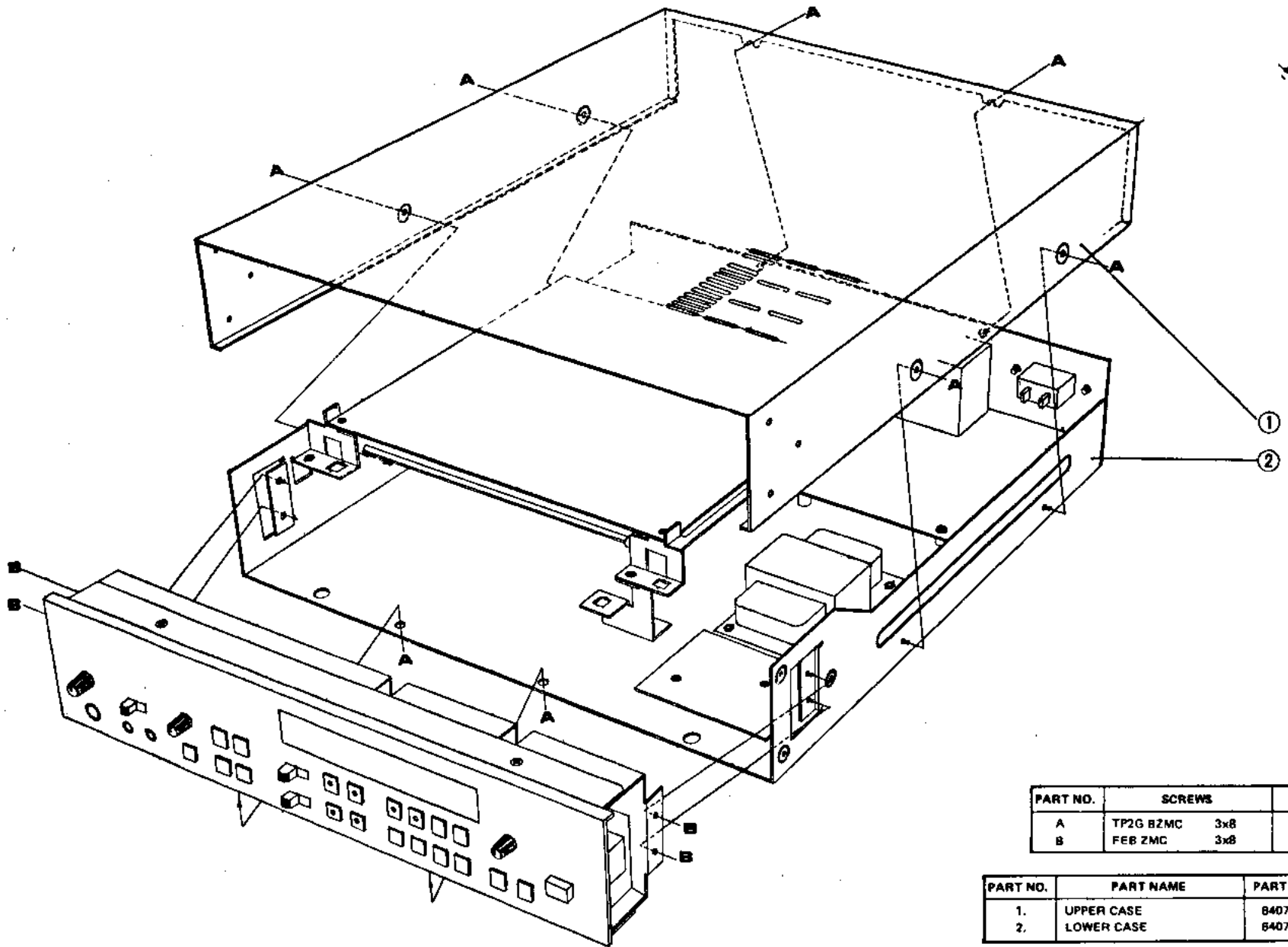

PART NO.	SCREWS	Q'TY
A	TP2G BZMC 3x8	8
B	FEB ZMC 3x8	4

PART NO.	PART NAME	PART CODE
1.	UPPER CASE	84073100
2.	LOWER CASE	84073200

# 4. BLOCK DIAGRAM

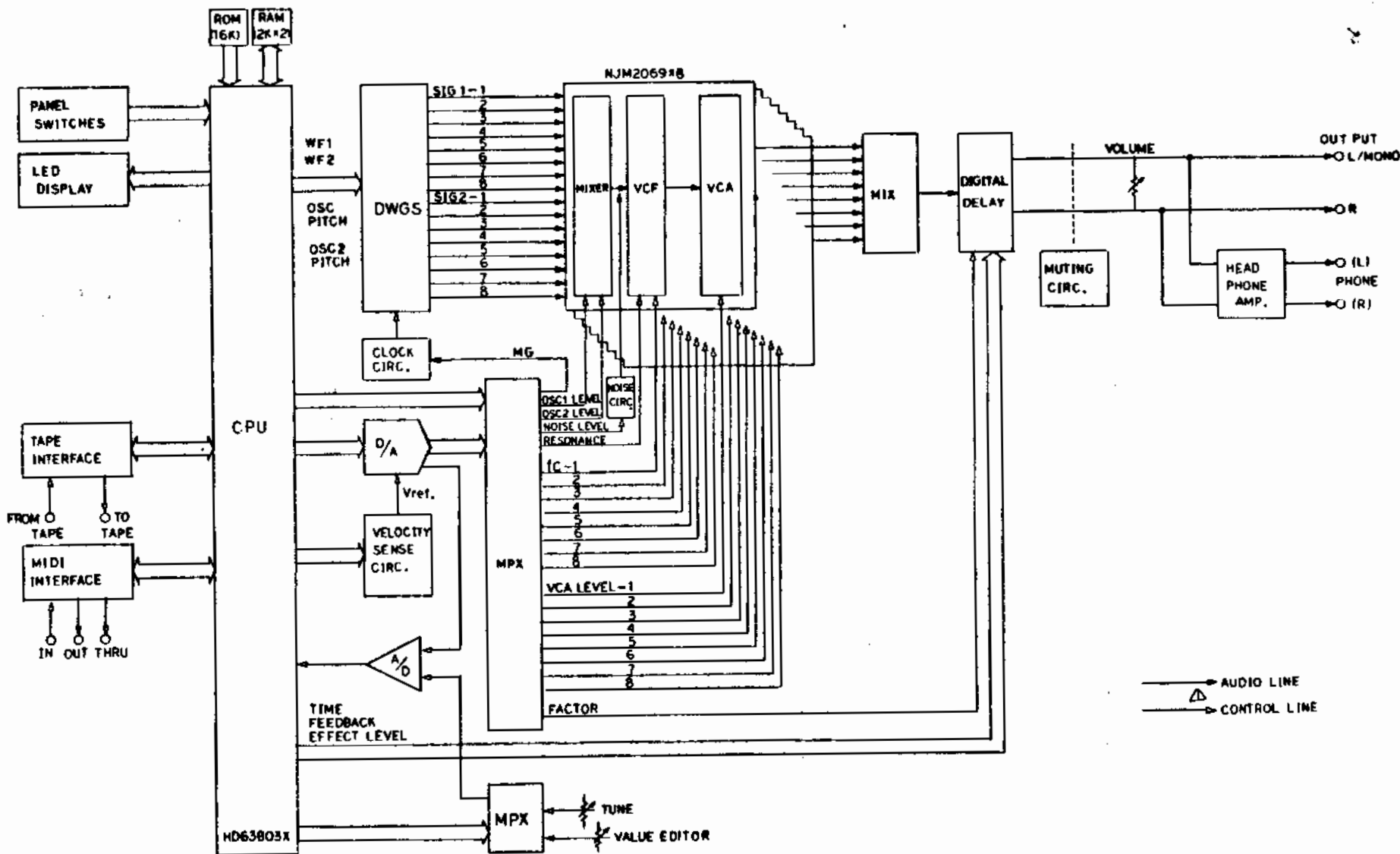

—●— AUDIO LINE  
 —△— CONTROL LINE



# 5. CIRCUIT DIAGRAM

KLM-771

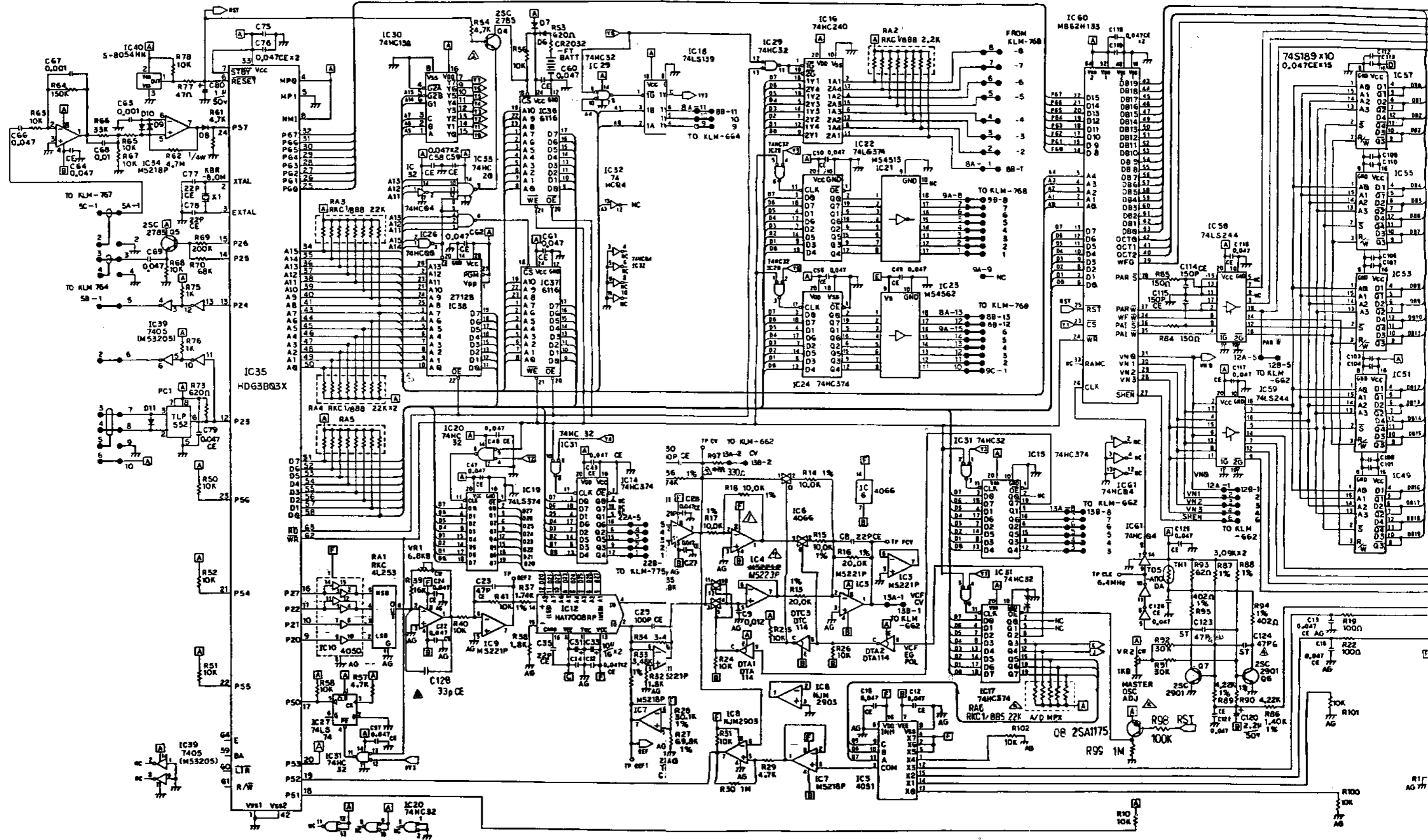

### KLM-771

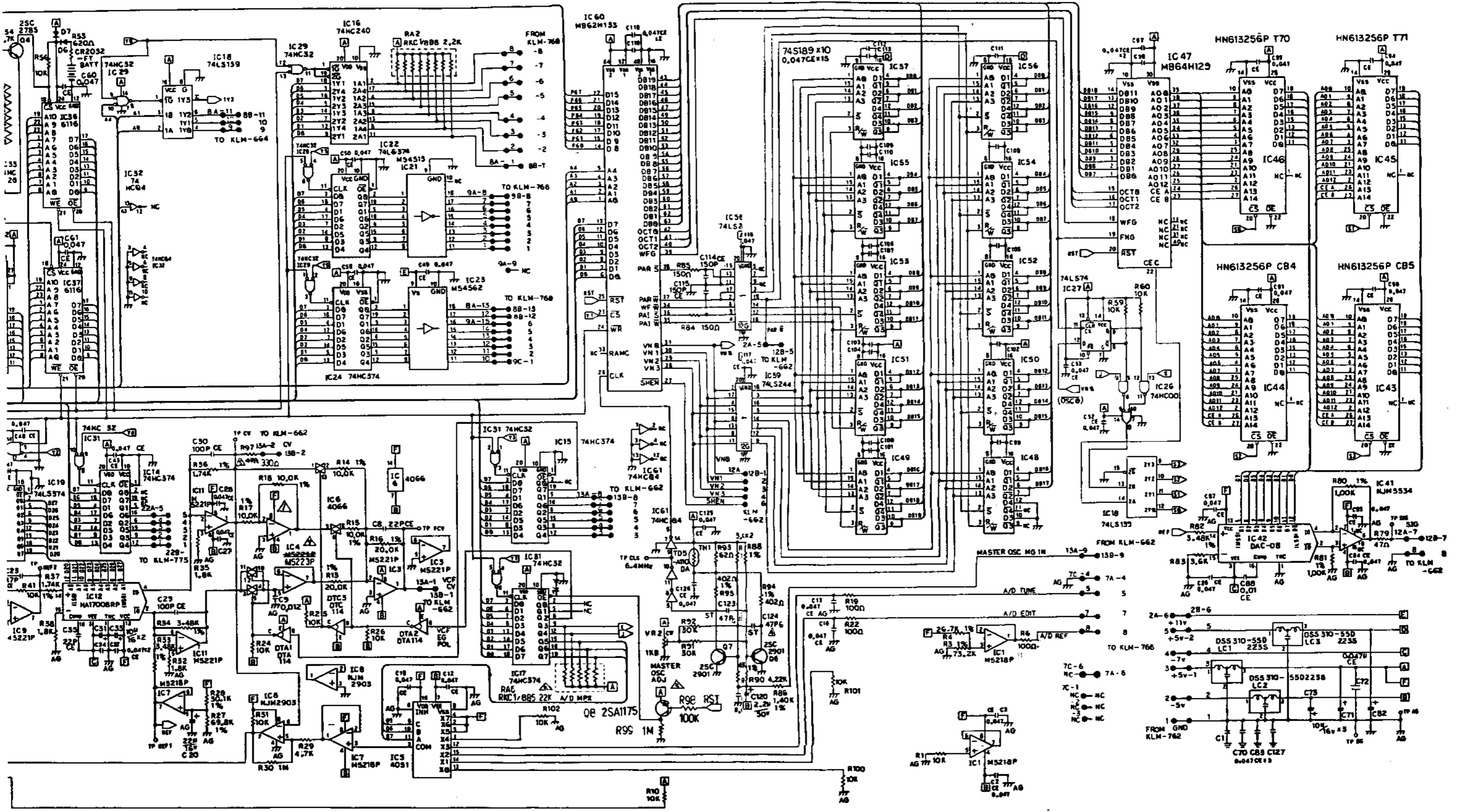



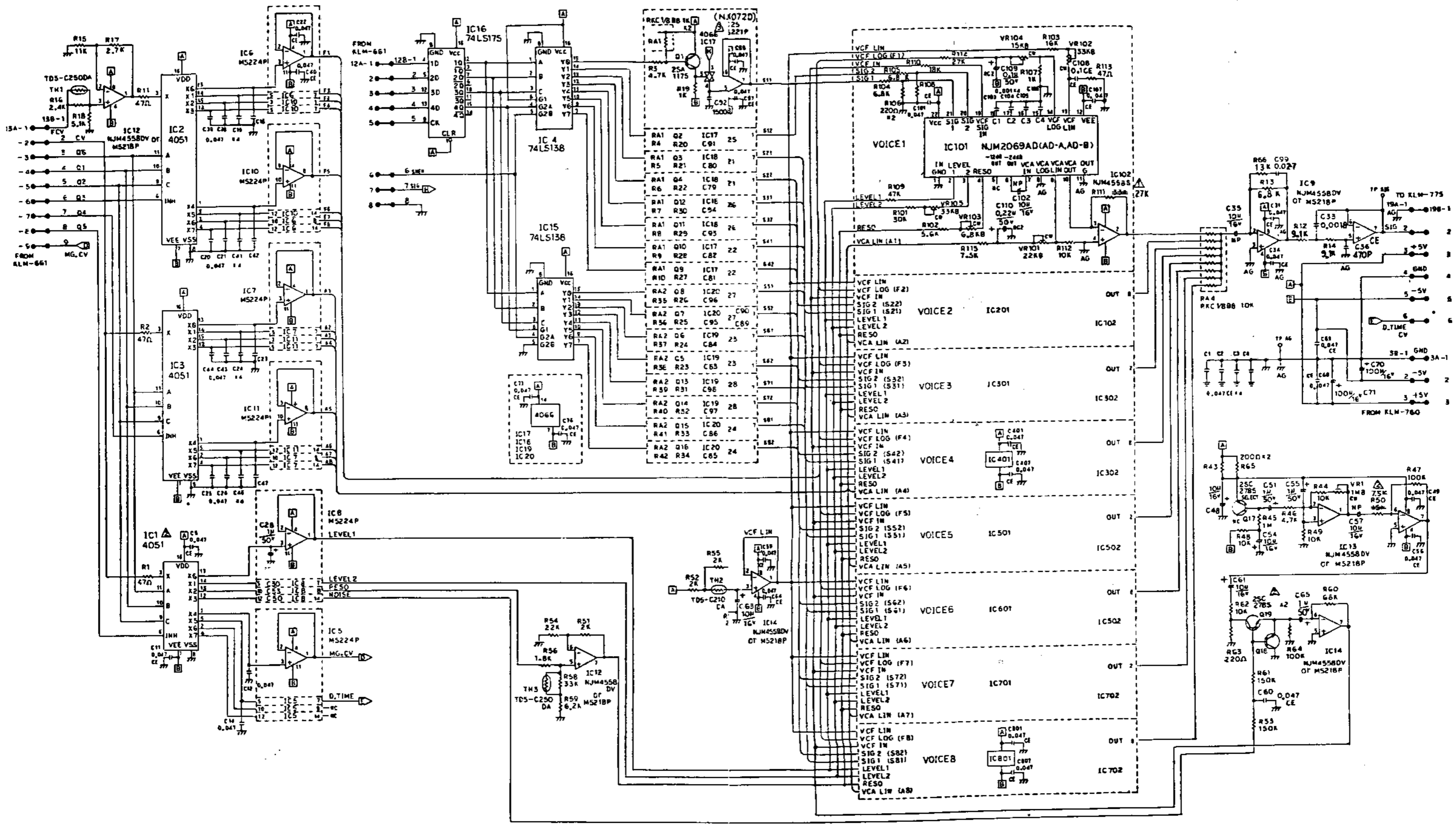

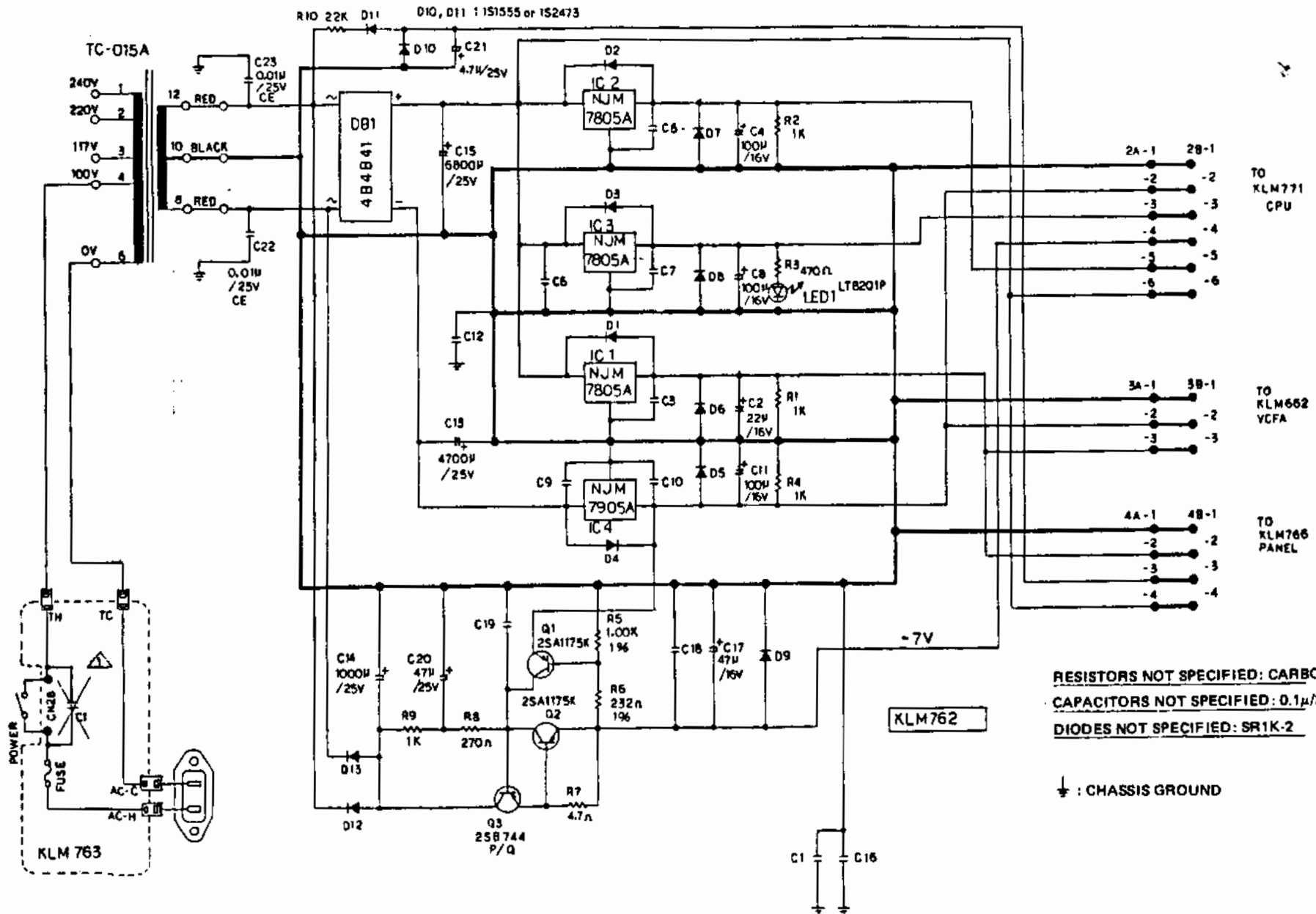

KLM-762, 763

RESISTORS NOT SPECIFIED: CARBON 1/4W  
 CAPACITORS NOT SPECIFIED: 0.1µ/25V CE  
 DIODES NOT SPECIFIED: SR1K-2

⊥ : CHASSIS GROUND

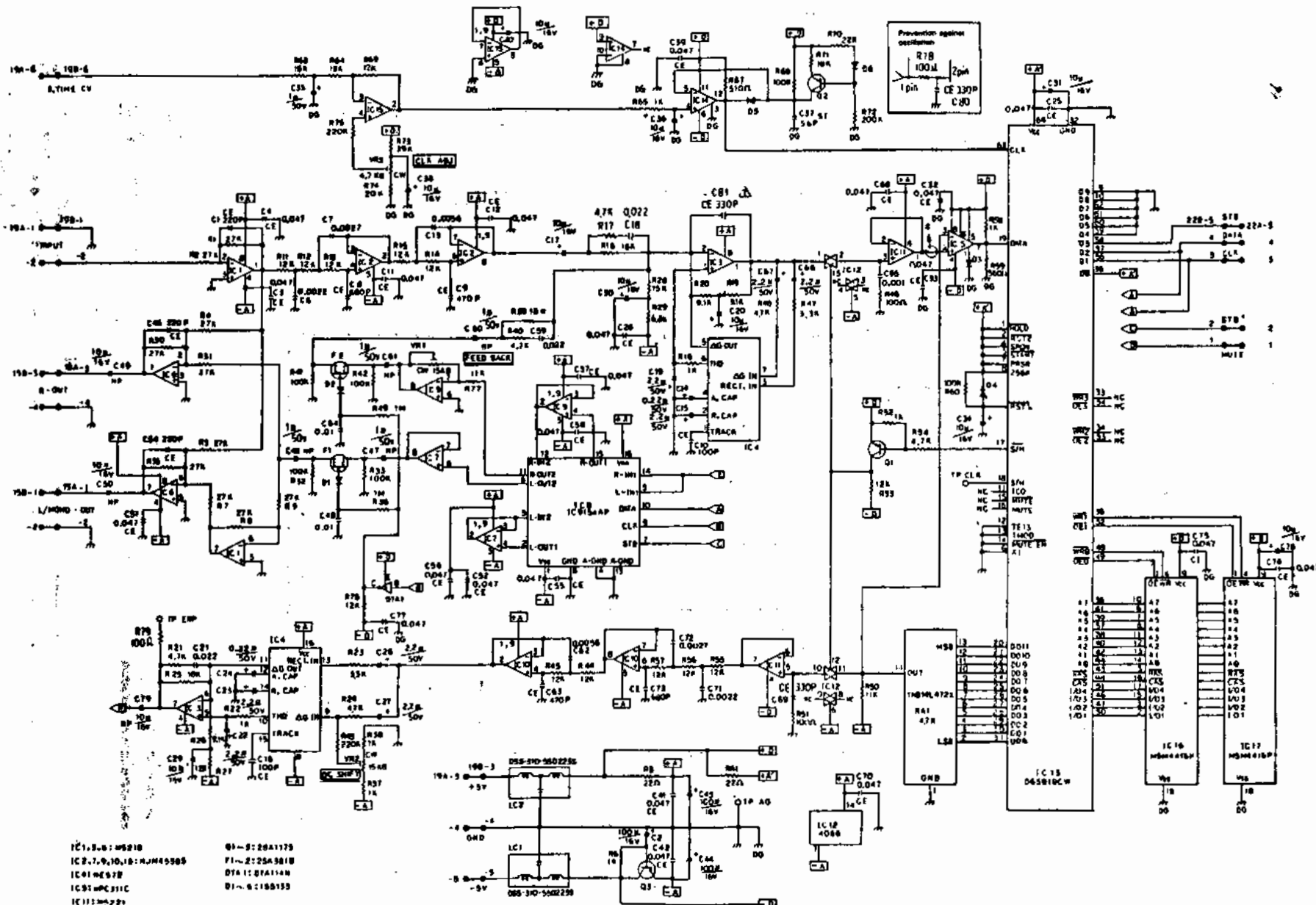

KLM-775

- IC1, 3, 6: 74LS00
- IC2, 7, 9, 10, 11: 74LS00
- IC4: 74LS00
- IC5: 74LS00
- IC11: 74LS00
- IC12: 74LS00
- IC13: 74LS00
- IC14: 74LS00
- IC16: 74LS00
- IC17: 74LS00
- Q1-Q10: 2N4117
- Q11-Q15: 2N4117
- Q16-Q18: 2N4117
- Q19-Q21: 2N4117
- Q22-Q24: 2N4117
- Q25-Q27: 2N4117
- Q28-Q30: 2N4117
- Q31-Q33: 2N4117
- Q34-Q36: 2N4117
- Q37-Q39: 2N4117
- Q40-Q42: 2N4117
- Q43-Q45: 2N4117
- Q46-Q48: 2N4117
- Q49-Q51: 2N4117
- Q52-Q54: 2N4117
- Q55-Q57: 2N4117
- Q58-Q60: 2N4117
- Q61-Q63: 2N4117
- Q64-Q66: 2N4117
- Q67-Q69: 2N4117
- Q70-Q72: 2N4117
- Q73-Q75: 2N4117
- Q76-Q78: 2N4117
- Q79-Q81: 2N4117
- Q82-Q84: 2N4117
- Q85-Q87: 2N4117
- Q88-Q90: 2N4117
- Q91-Q93: 2N4117
- Q94-Q96: 2N4117
- Q97-Q99: 2N4117
- Q100: 2N4117

KLM 764 Rear Jack

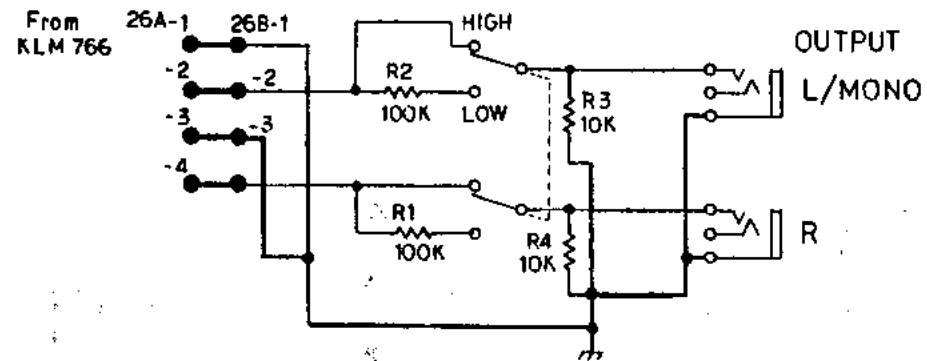

KLM-765 Front Jack

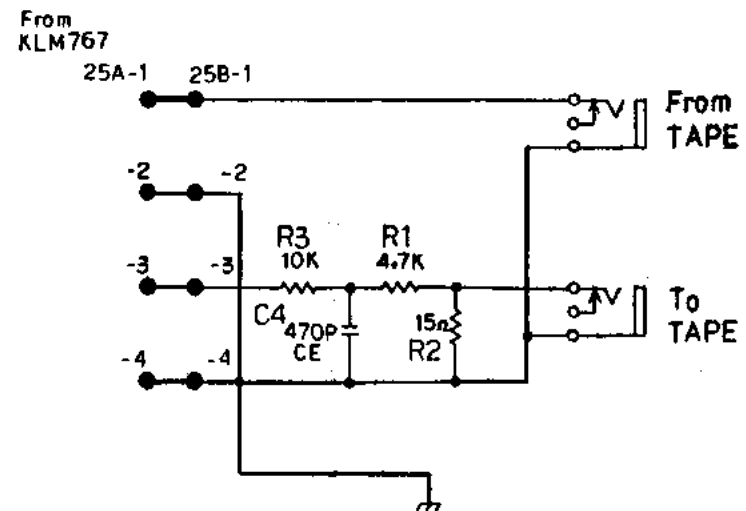
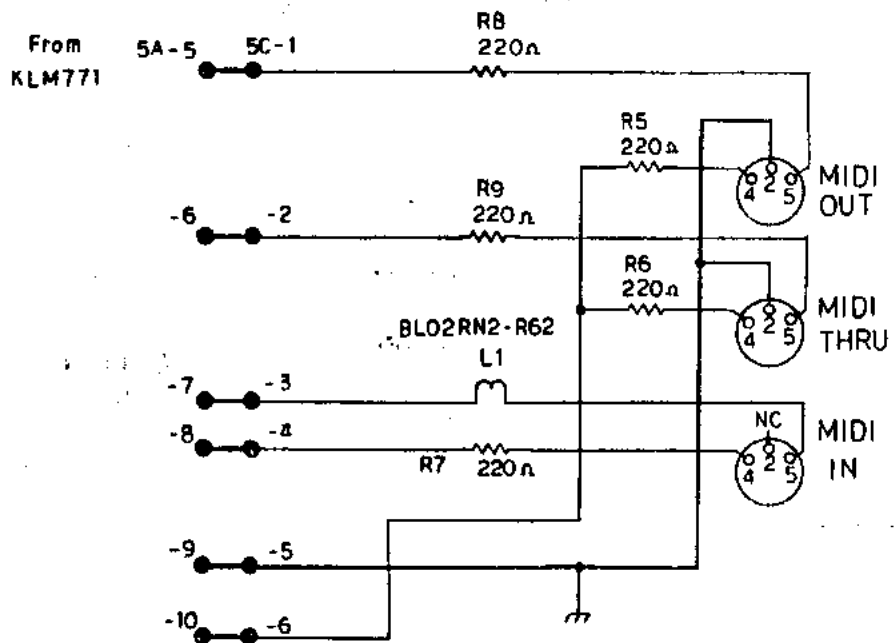
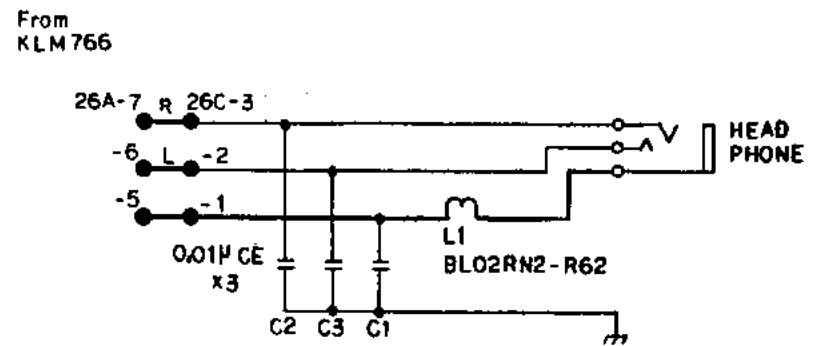

KLM-764, 765

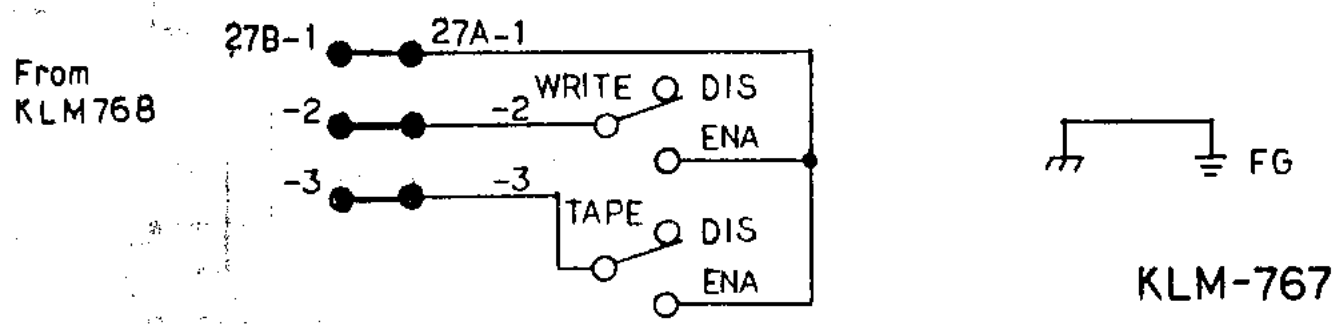
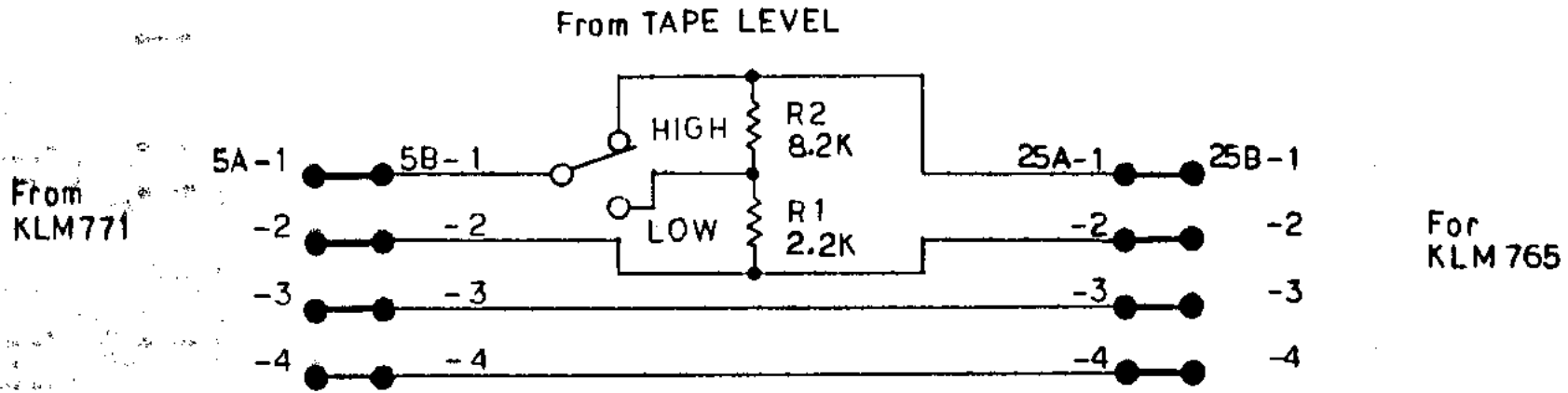

PANEL 2    SLIDE SW.

KLM-767

-22-

KLM 768 PANEL3 LED.SW

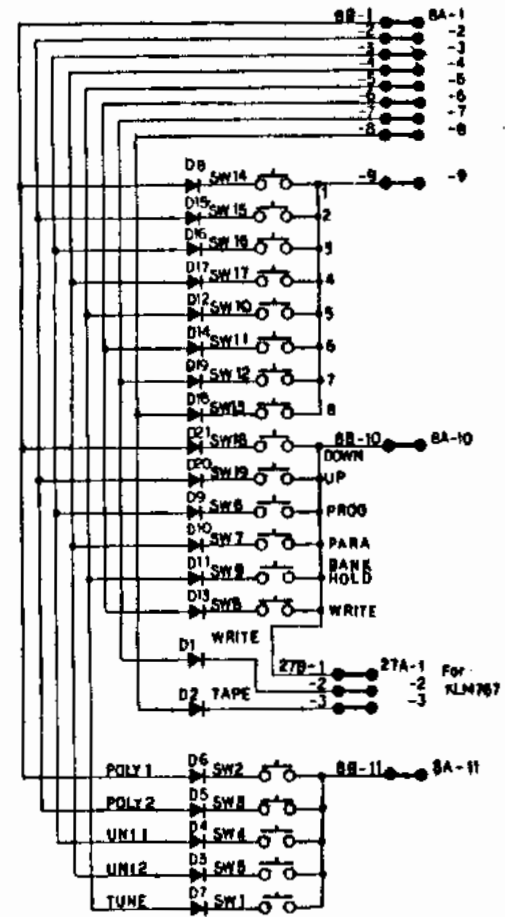
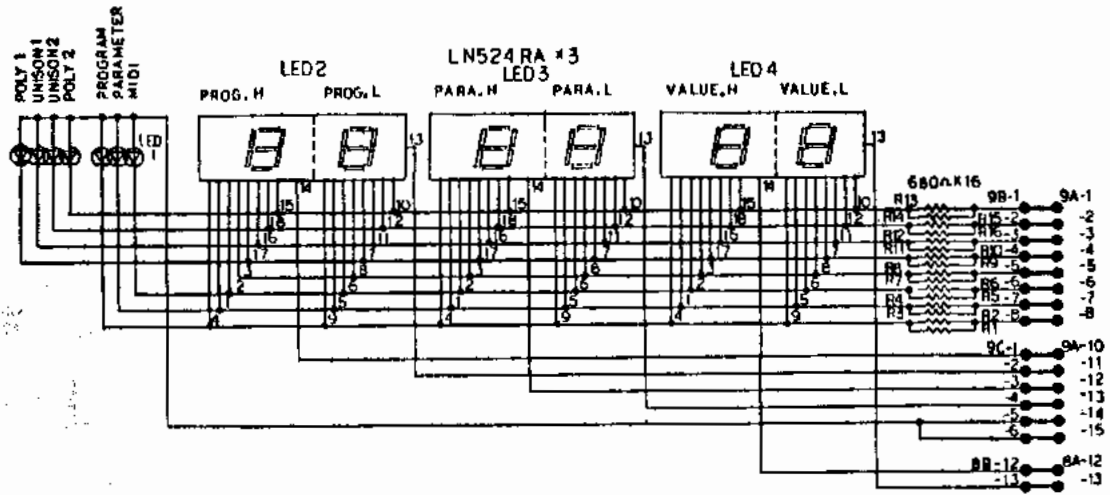

KLM-766, 768, 769

DIODES NOT SPECIFIED: 1S1555 or 1S2473

23

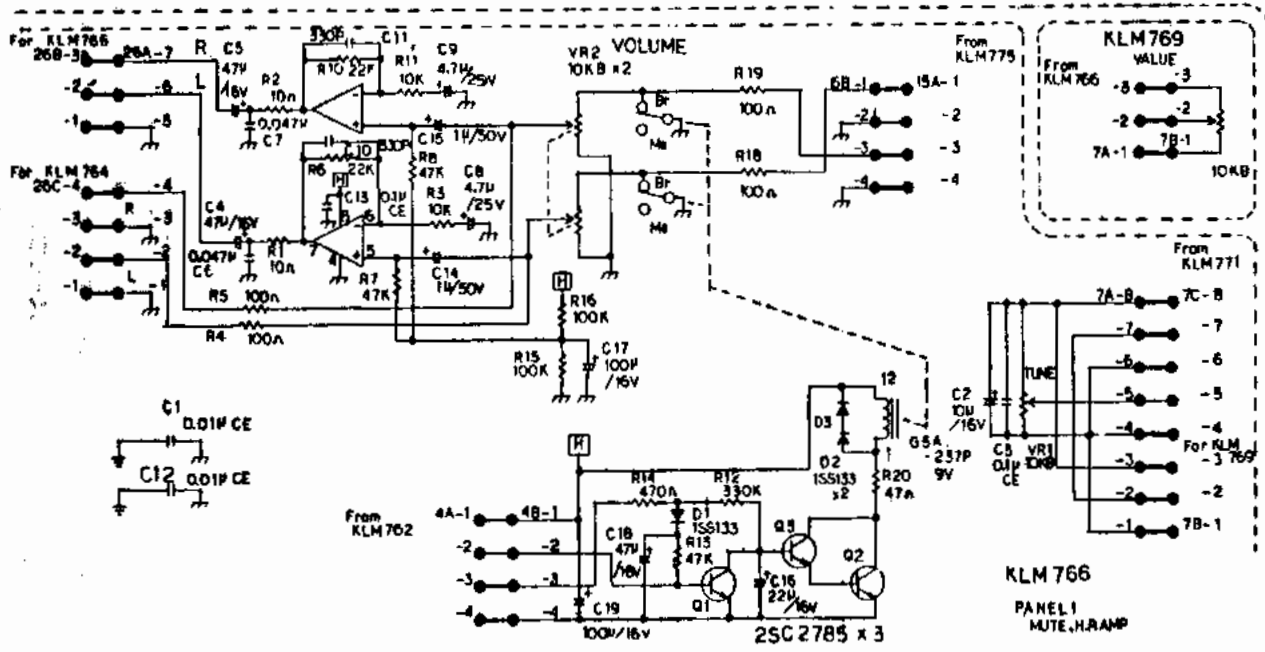

KLM 766  
 PANEL1  
 MUTE,H.RAMP



# 6. P.C. BOARD

KLM-763

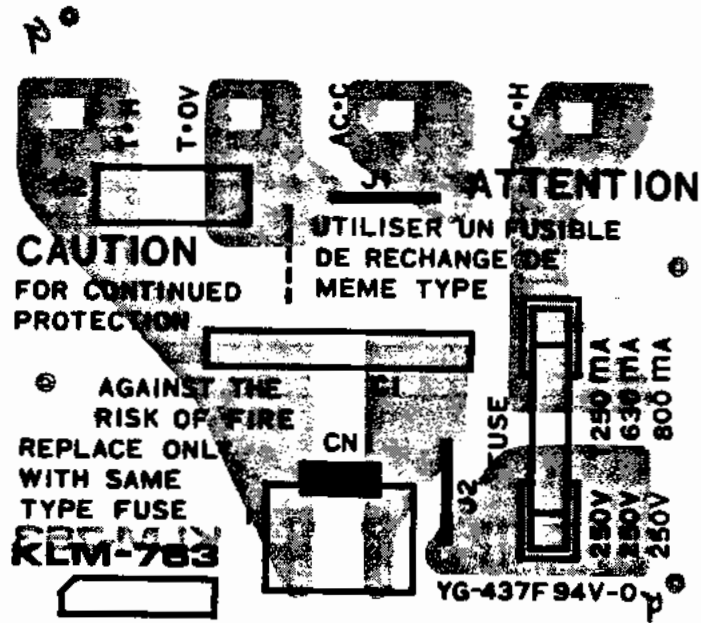

KLM-762

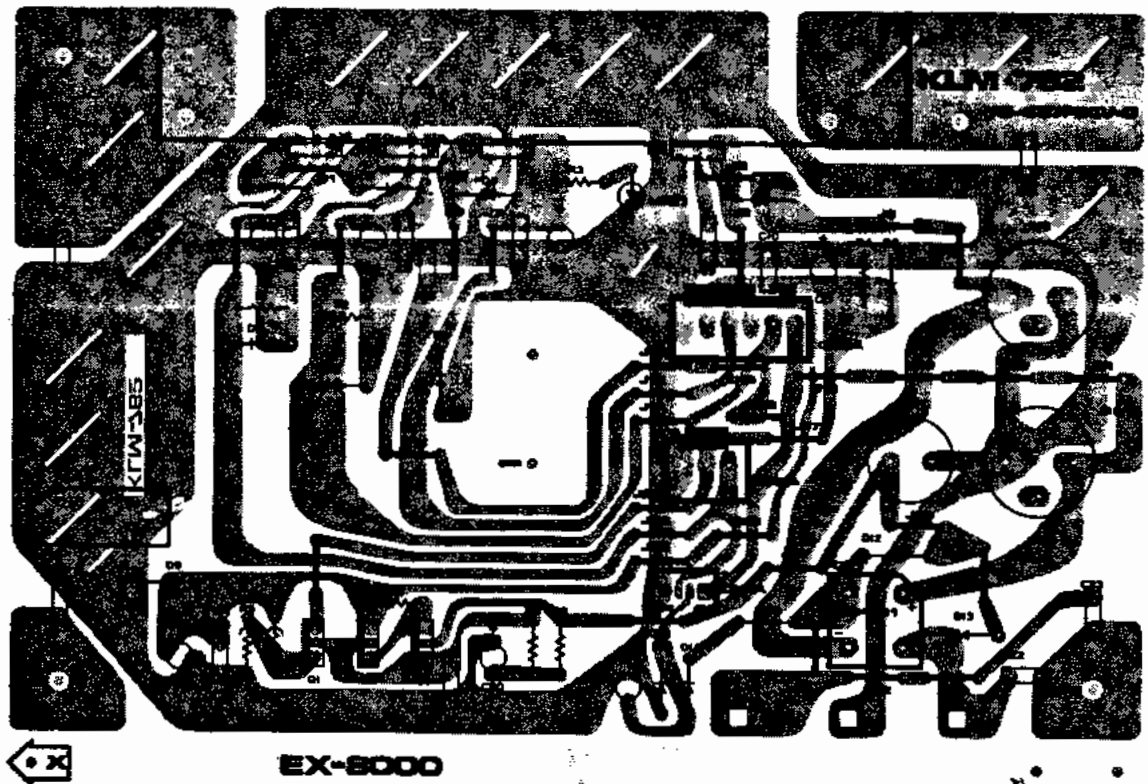

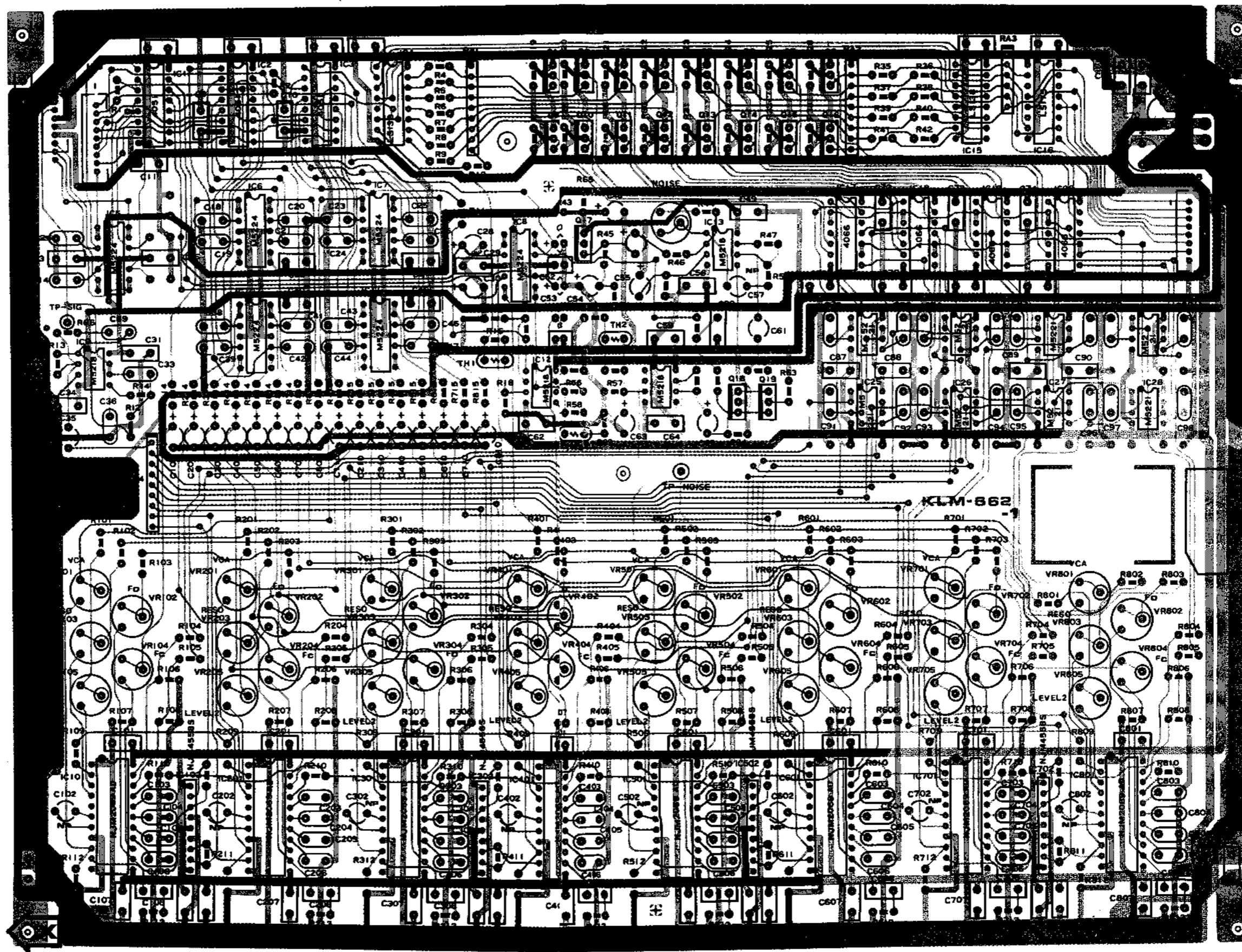



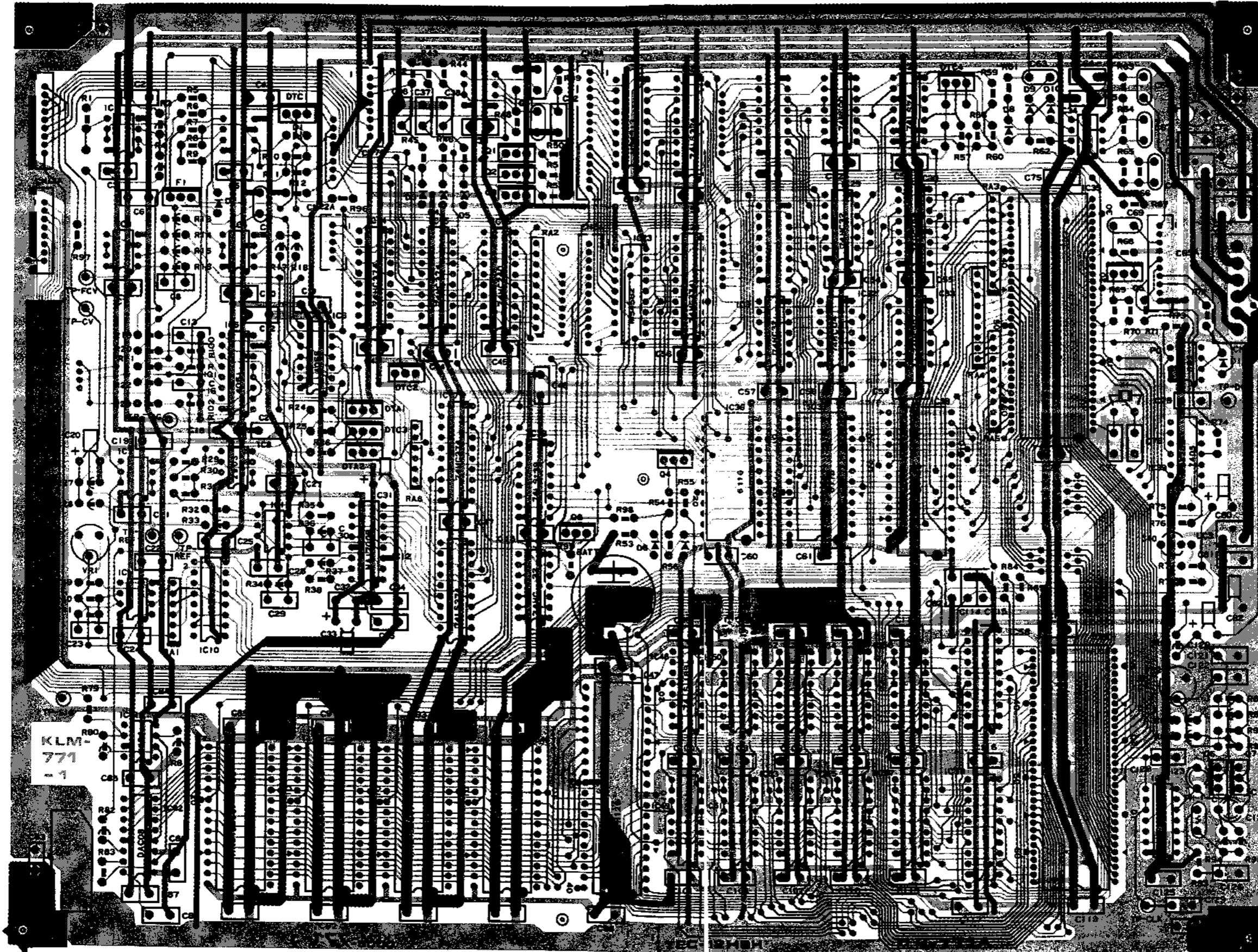



KLM-767

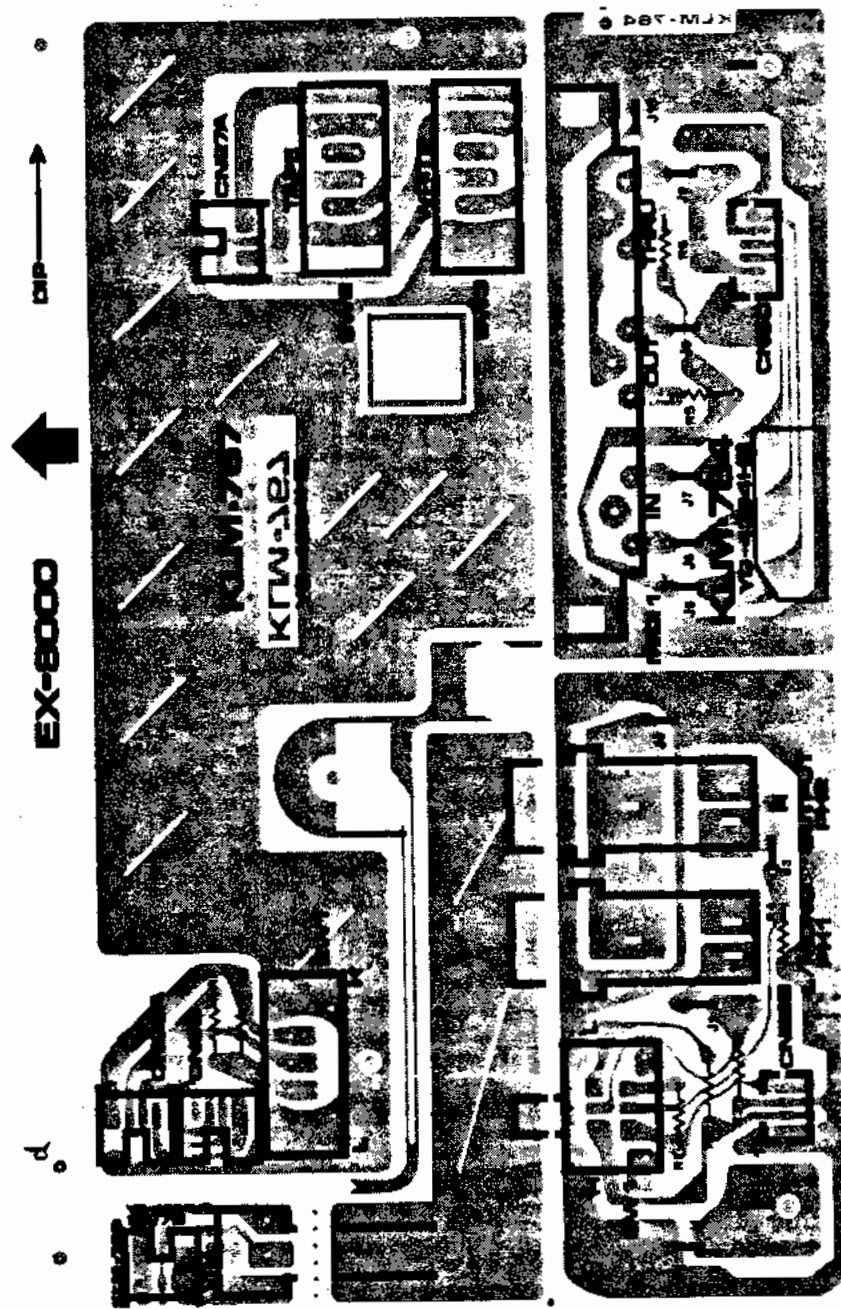

KLM-768

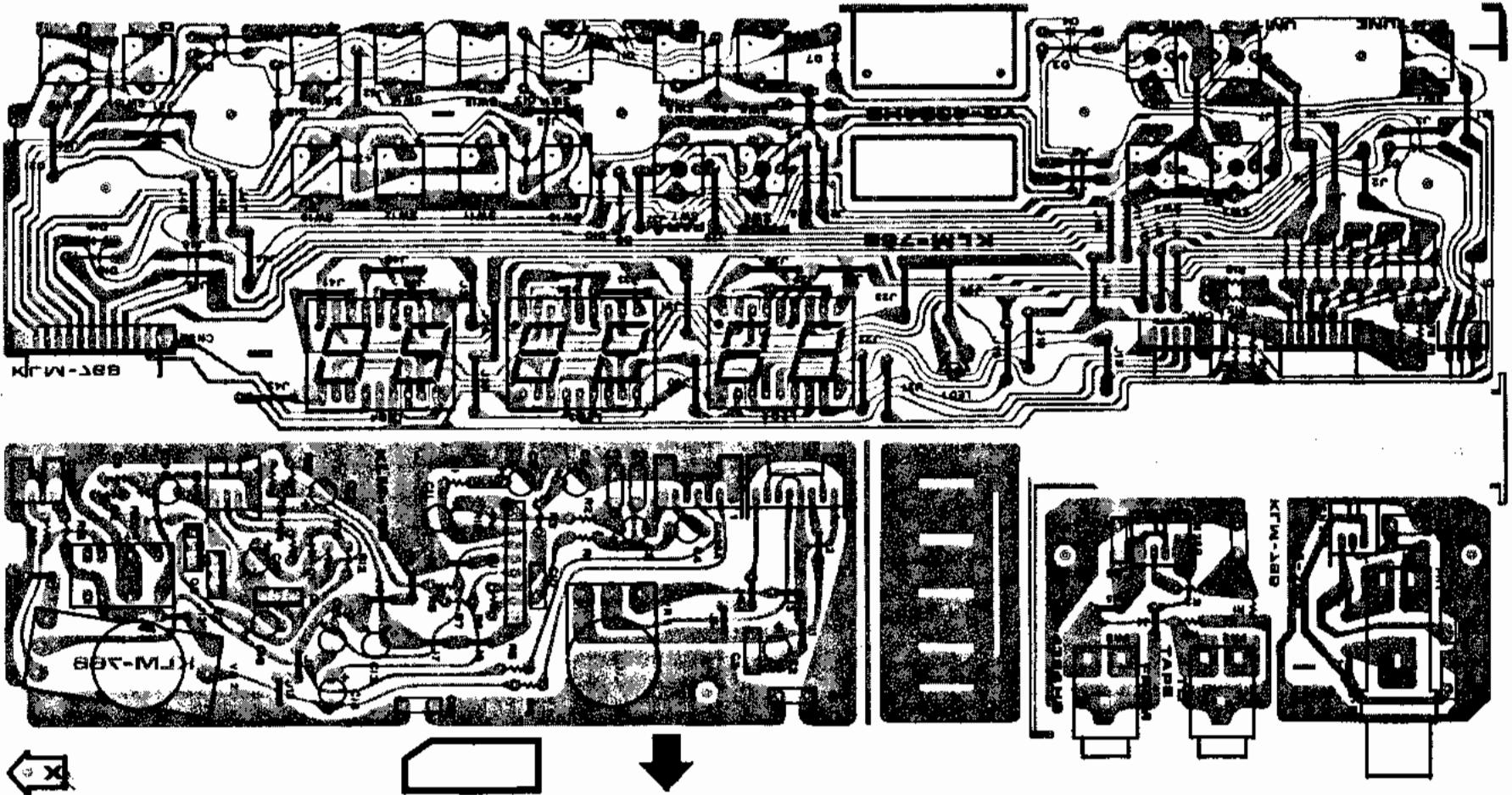



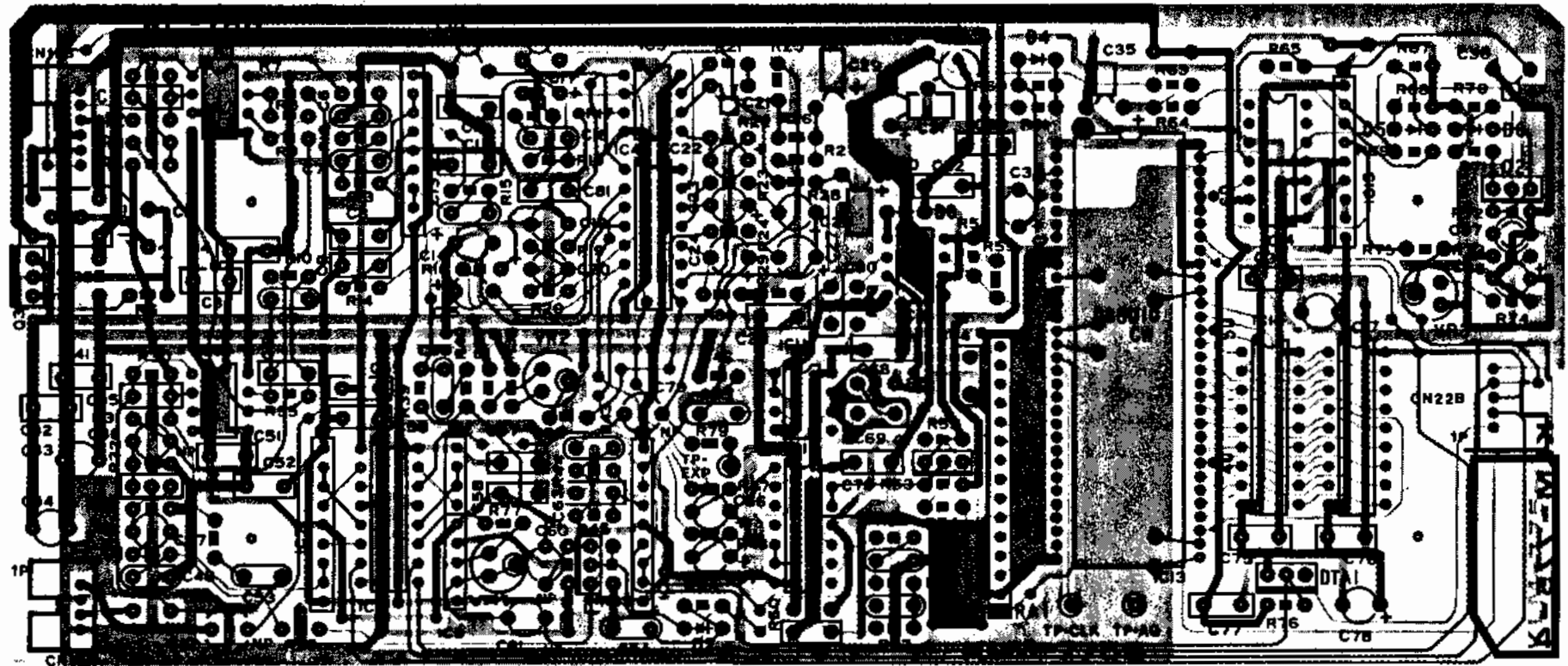

-31-

KLM-775



# 7. CIRCUIT DESCRIPTIONS

## 1. Hardware:

NAME	DESCRIPTION	PC BOARD
CPU 63B03X (8 bit, 2MHz)		KLM-771
ROM 27128 (N-MOS 16KB)	System program, data table	KLM-771
RAM1 6116 (C-MOS 2KB)	Tone data, backup	KLM-771
RAM2 6116 (C-MOS 2KB)	System use	KLM-771
Sound source DWGS	2 DC0 x 8 voice	KLM-771
Wave table ROM 613256	(256Kbit x 4) 16 Waveforms	KLM-771

PC BOARD	NAME
KLM-662	VCF, VCA, noise circuit, 8-voice mixer
KLM-771	Main circuit (DWGS)
KLM-775	Digital delay circuit, stereo amp circuit
KLM-762/763	Power supply circuit
KLM-764	Rear jack
KLM-765	Front jack
KLM-766	Mute, headphone amp
KLM-768	7-segment LEDs, switch matrix

## 2. Memory map

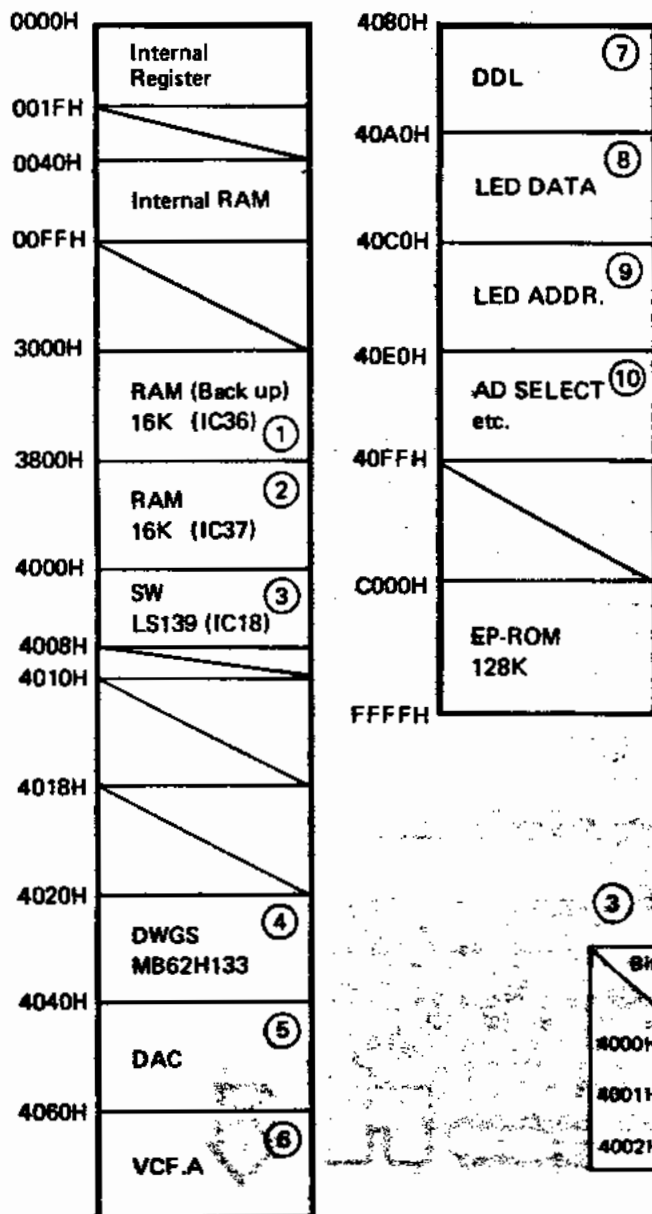

① RAM (Battery Back up) 16K Bytes

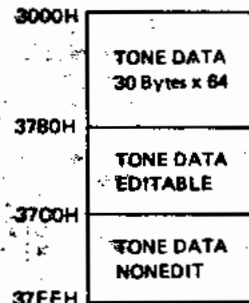

② RAM 16K Bytes  
FOR SYSTEM PROGRAM

③ SW

Bit	7	6	5	4	3	2	1	0
4000H	B	7	6	5	4	3	2	1
4001H	Tape Enab.	Wr. Enab.	WRITE	B.H	PAR	PRG	UP	DOWN
4002H				A4	UNS2	UNS1	POLY2	POLY1

④ DWGS

Bit	7	6	5	4	3	2	1	0
4020H	VOICE1 OSC1 FREQ. DATA BOTTOM							
4021H	VOICE1 OSC2 *							
?	?							
4030H	WAVEFORM V.1 OSC1							
4031H	OSC2 *							
?	?							
403EH	WAVEFORM V.8 OSC1							
403FH	OSC2 *							

⑤ DAC - HC374 (IC19)

FOR DAC (HA17008) DATA LATCH 8 BIT

⑥ VCF, VCA EG SELECT

Bit	7	6	5	4	3	2	1	0	HEX	JOB
4060H	•	-	-	-	-	-	-	-		Fc 1 ~ 8
	-	1	1	1	1	-	-	-	78	INHIBIT
									58	LEVEL 1
									59	" 2
									5A	RESONANCE
									5B	NOISE
									5C	MG 0V
									5D	DDL 0V
									60	VCA0 EG
									?	?
									67	VCA7 EG
									70	VCF0 EG
									?	?
									77	VCF7 EG

⑦ DDL CONTROL

Bit	7	6	5	4	3	2	1	0	JOB
4080H								•	MUTE
							•		STB (TOS154)
						•			CLK
					•				DATA SERIAL
			•						STB (D850100W)

⑧ LED ⑨ 4000H

Bit	7	6	5	4	3	2	1	0	DISP.
40A0H + 0	DOT		A	A	A	A	A	A	PROG H
1									" L
2	DOT								PARA H
3									" L
4	PROG	PARA	MIDI		POLY 1	UNS 1	UNS 2	POLY 2	
5	"	"	"		"	"	"	"	
6									VAL H
7	DOT								" L

⑩ AD SELECT etc.

Bit	7	6	5	4	3	2	1	0	
40E0H						•	•	•	AD SELECT
						0	1	0	Edit Volume
						0	1	1	Tune "
			•	•					WAVE FORM SELECT
			0	0					OSC1 1 ~ 8
			0	1					" 9 ~ 16
			1	0					OSC2 1 ~ 8
			1	1					" 9 ~ 16
		•							VCF EG POLARITY
	0								
	1								

3. Using the diagnostics and utility programs

To test EX-8000 functions you can use the built-in diagnostics and utility programs. These are executed by holding down particular number keys (in the synthesizer's "programmer" section) and at the same time turning on the power (i.e., resetting the unit).

1,2: (1) Displays system ROM version number. The system ROM version number is shown in the value display.

(2) Sets write protect attribute. This is useful when displaying the synthesizer in a shop. It prevents anything from being written into memory. Effective on versions 850904 and later.

5,6: Reference voltage adjustment mode. Refer to the adjustment procedures.

7,8: Tuning mode.  
 Tune fixed, touch sense maximums setting, voice indication.  
 Refer to adjustment procedures.

5,8: RAM clear mode.  
 Erases 64 sound program settings from memory.

4. Tape interface format

1. Modulation system

"1" .....  $t = 320 \mu s$   
 "0" .....  $2t = 640 \mu s$

Example:

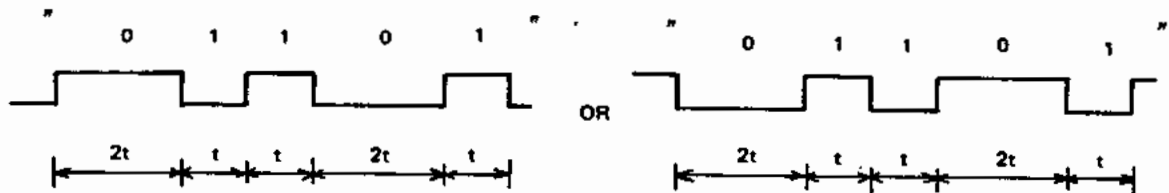

2. Format of one set of program data

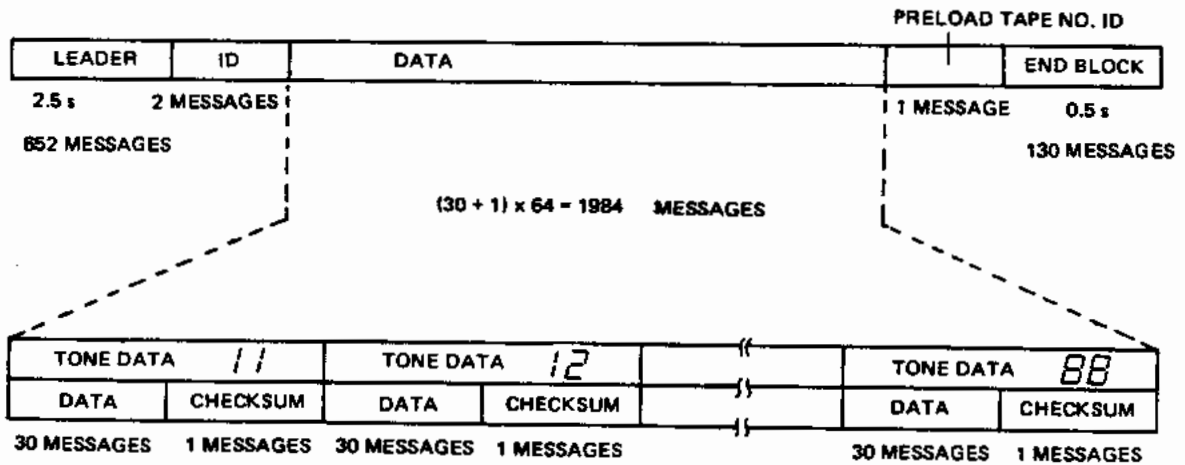

3. Format of one message

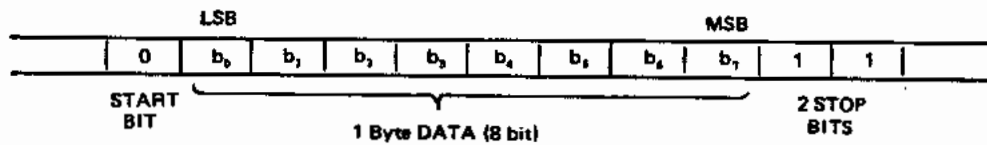

- 3.1 LEADER DATA "FF H" (652 MESSAGES)
- 3.2 ID DATA
  - ID1 "42 H" KORG
  - ID2 "03 H" X-300
- 3.3 CHECKSUM DATA ONE TONE DATA
  - $\sum_{n=1}^{30} D_n$  AND "FFH"
- 3.4 PRELOAD TAPE NORMAL No. ID (FOR TEST) "00 H"
- 3.5 END BLOCK DATA "FFH" (130 MESSAGES)



## 5. Main circuit explanation

The EX-8000 is a programmable synthe module can be connected to MIDI keyboards and other MIDI devices. The DWGS used is the same as for the DW-8000 and adjustments, etc., are also the same.

A Simple Explanation Using MIDI Note Data as an Example. When note data are input from the MIDI IN terminal, they enter port 23 of the CPU (63B03X) through the photo coupler (TLP-552) and are then output as 16-bit data (PAI data or wave form data) by the system program of IC38 (HN4827128). These data are input to IC60 (MB62H133) together with 5-bit addresses. A WRITE signal is output from the PAI  $\bar{W}$  terminal of IC60, and the PAI data are stored in IC51, 53, 55, 57 of 74LS189. Wave form data are stored in IC49 by a WRITE signal from the WF  $\bar{W}$  terminal. In the same way, PAR data are stored in IC48, 50, 52, 54, 56 by a WRITE signal from the PAR  $\bar{W}$  terminal.

These data are called out by a PAR  $\bar{S}$  and PAI  $\bar{S}$  READ signal, are added at IC60 and output as 18-bit data. DB7 - DB18 contained in these data are input to IC47 (MB64H129) together with octave select data (Oct 0 - Oct 2). At the same time, these 18-bit data are stored in IC48, 50, 52, 54, 56 as PAR data and are again added to the PAI data.

The data output from IC60 are decoded by IC47 (MB64H129), are input as WAVE TABLE addresses to a WAVE TABLE ROM selected by  $\bar{CS}$ . The wave form data specified by these addresses are output as D0 - D7 8-bit data. These data are wave formed by D/A convertor IC42 (DAC08) and are output through IC41 (NJM5534).

See the section below concerning oscillator operation.

### Oscillator operation

The PAI (phase angle increment) value and PAR (phase angle register) value are added and the result is stored again in the PAR. The PAR value is used as the wave table address. The wave table stores different harmonic configuration data for each octave on the keyboard.

IC47 (MB64H129) performs the processing needed to use the PAR value as the wave table address.

Finally, data read from the wave table is converted to an analog waveform by a D/A converter.

Time division multiplexing enables dual oscillator 6-voice sound source capability.

Maximum simultaneous output of this system is 8 voices x 2 oscillators.

**Note:** Given a sampling frequency of 50 kHz, PAI data  $N = 2^{18} \times f / 50 \times 10^3$  (where  $f$  is the pitch frequency) is rounded to an integer value for  $N$  and converted to a hexadecimal number.

The main LSI chips are the CMOS gate array IC47 (MB64H129) and IC60 (MB62H133), the wave-table 256K mask ROM IC43 and IC46 (HN613256), the ten TTL 64-bit RAM chips for PAI & PAR (IC48~IC57; S189), the 8-bit D/A converter IC42 (DAC-08), decoder chips IC50, IC59 (LS244), KLM-662 IC16 (LS175), IC14, IC15 (LS138), as well as S/H analog switches (IC17~IC20; 4066) and OP AMPS (IC21~IC25; 072).

IC60 (MB62H133) is a 64-pin LSI with about 800 gates handling major aspects of the system including the CPU interface, timing generation, and adder.

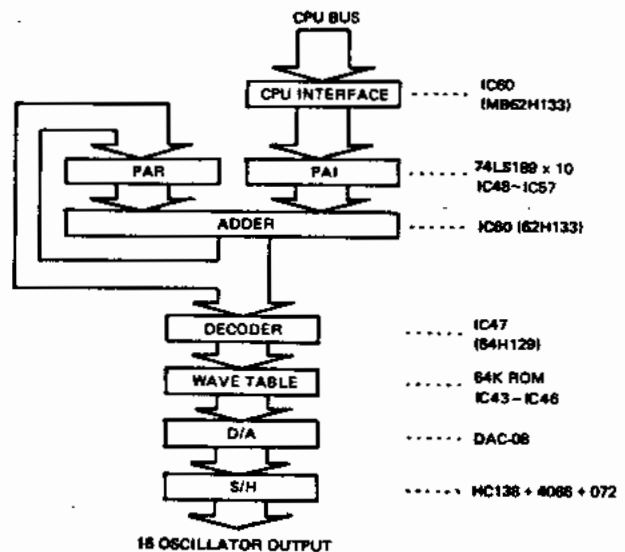

**MB62H133 TERMINAL NAMES**

Pin No.	Type	Term	Pin No.	Type	Term	Pin No.	Type	Term
1	Input	A0	23	Input	CS	44	Bus	DB18
2	Input	A1	24	Input	WR	45	Bus	DB17
3	Input	A2	25	Input	RST	46	Bus	DB16
4	Input	A3	26	Input	CLK	47	Bus	DB15
5	Input	A4	27	Output	SHEN	48	Power supply	VSS
6	Input	D0	28	Output	VN3	49	Bus	DB14
7	Input	D1	29	Output	VN2	50	Bus	DB13
8	Input	D2	30	Output	VN1	51	Bus	DB12
9	Input	D3	31	Output	VN0	52	Bus	DB11
10	Input	D4	32	Power supply	VDD	53	Bus	DB10
11	Input	D5	33	Output	RAMC	54	Bus	DB9
12	Input	D6	34	Output	WFW	55	Bus	DB8
13	Input	D7	35	Output	PAIW	56	Bus	DB7
14	Input	D8	36	Output	PAIS	57	Bus	DB6
15	Input	D9	37	Output	PARW	58	Bus	DB5
16	Power supply	VSS	38	Output	PARS	59	Bus	DB4
17	Input	D10	39	Output	WFG	60	Bus	DB3
18	Input	D11	40	Output	OCT2	61	Bus	DB2
19	Input	D12	41	Output	OCT1	62	Bus	DB1
20	Input	D13	42	Output	OCT0	63	Bus	DB0
21	Input	D14	43	Bus	DB19	64	Power supply	VDD
22	Input	D15						

IC47 (MB64H129) is used mainly for wave table ROM address decoding; it is a 40-pin LSI having about 400 gates.

**MB64H129 TERMINAL NAMES**

Pin No.	Type	Term	Pin No.	Type	Term	Pin No.	Type	Term
1	Input	DB0	15	Input	OCT0	28	Output	AO9
2	Input	DB1	16	Input	OCT1	29	Output	AO8
3	Input	DB2	17	Input	OCT2	30	Power supply	VDD
4	Input	DB3	18	Input	WFG	31	N.C.	
5	Input	DB4	19	Input	FNG	32	Output	AO7
6	Input	DB5	20	Input	RST	33	Output	AO6
7	Input	DB6	21	N.C.		34	Output	AO5
8	Input	DB7	22	Output	CEC	35	Output	AO4
9	Input	DB8	23	Output	CEB	36	Output	AO3
10	Power supply	VSS	24	Output	CEA	37	Output	AO2
11	N.C.		25	Output	AO12	38	Output	AO1
12	Input	DB9	26	Output	AO11	39	Output	AO0
13	Input	DB10	27	Output	AO10	40	N.C.	
14	Input	DB11						

IC43 - IC46 (HN613256) store digitally encoded harmonic waveforms of the harmonics 2, 5, 10, 20, 40, 80, 160 and 320.

Here a waveform including the 320th harmonic refers to addition of the sine value 320 times at a particular phase.

### CPU 63B03X

#### PIN CONFIGURATION

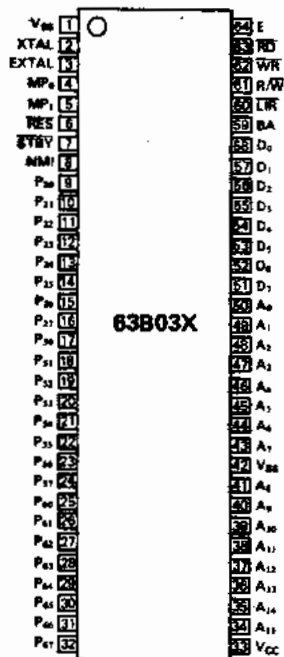

#### BLOCK DIAGRAM

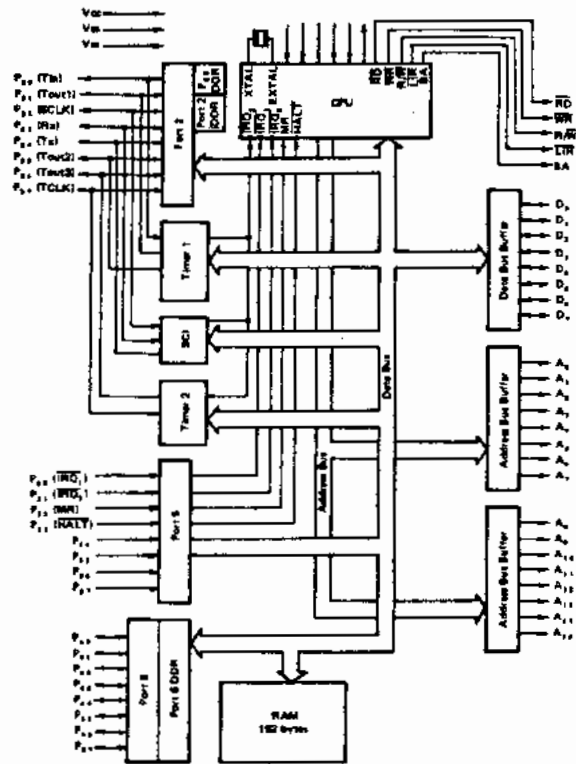

#### 5) Panel switch scanning

In similar fashion to keyboard scanning, 2-bit addresses in the range A0~A1 are decoded by the address decoder LSI139 (IC18) and supplied to the switch matrix. The output goes to octal buffer HC240 (IC16) (the same as used by the keyboard) and is passed to the data bus.

#### 6) LED Display

The LED display is software controlled. Latch HC374 (IC22, IC24) takes LCD display data from the D0~D7 8-bit data bus to operate LED drivers 54513 and 54562.

#### 7) Digital delay

The KLM-775 board has its own dedicated delay gate array,  $\mu$ PD65010CW-113. The delay circuit comprises this gate array, 64KB dynamic RAM x 2, ADC, DAC, and analog compander. The delay time can be specified.

#### CPU 63B03X STATE OF PORT

Port	Pin	Function
P20	9	Velocity Sens. Control 3 Bit
P21	10	Velocity Sens. Control 2 Bit
P22	11	Velocity Sens. Control 1 Bit
P27	16	Velocity Sens. Control 0 Bit
RX	12	MIDI RX
TX	13	MIDI TX
P25	14	TAPE OUT
P26	15	TAPE IN
P52	19	A/D Compare
P53	20	+5
P57	24	TAPE IN
P60	25	DWGS FREQ. DATA D15
P61	26	DWGS FREQ. DATA D14
P62	27	DWGS FREQ. DATA D13
P63	28	DWGS FREQ. DATA D12
P64	29	DWGS FREQ. DATA D11
P65	30	DWGS FREQ. DATA D10
P66	31	DWGS FREQ. DATA D 9
P67	32	DWGS FREQ. DATA D 8

**μPD6510 CW-113 TERMINAL NAMES**

Pin No.	Pin Name	I/O	Pin No.	Pin Name	I/O	Pin No.	Pin Name	I/O
1	HOLD	I	23	DO8	O	44	A0	O
2	RST1	I	24	DO7	O	45	WR0	O
3	RST2	I	25	DO6	O	46	IO3	I/O
4	SPON	I	26	DO5	O	47	IO2	I/O
5	STRT	I	27	DO4	O	48	CAS	O
6	X1	I	28	DO3	O	49	OE0	O
7	PRSR	I	29	DO2	O	50	IO1	I/O
8	256K	I	30	DO1	O	51	IO4	I/O
9	D9	I	31	DO0	O	52	OE1	O
10	D8	I	32	GND	0V	53	OE2	O
11	TCO	O	33	WR3	O	54	OE3	O
12	TE13	I	34	WR2	O	55	D0	I
13	TMOD	I	35	WR1	O	56	D1	I
14	MTEN	I	36	A7	O	57	D2	I
15	MUTB	O	37	A4	O	58	D3	I
16	MUTE	O	38	A3	O	59	D4	I
17	SHB	O	39	A5	O	60	D5	I
18	SH	O	40	A2	O	61	D6	I
19	DATA	I	41	A6	O	62	D7	I
20	DO11	O	42	A1	O	63	CLK	I
21	DO10	O	43	RAS	O	64	VDD	+5V
22	DO9	O						

**PIN CONFIGURATION**



# 8. ADJUSTMENT PROCEDURES

PROGRAM NO. ADJUST MODE PARAM MEMORY	11 POLY1 23	12 POLY1 23	13 POLY1 31	14 POLY1 31	15 POLY1 26	16 POLY1 72	17 POLY1 72	18 POLY1 71	21 POLY1 73
OSC 1 out	8	8	8	8	8	8	8	8	8
level	16	16	16	16	6	16	16	16	16
12	16	16	16	16	6	16	16	16	16
13	31	0	0	0	0	31	31	31	31
A.BAND in	0	0	0	0	0	0	0	0	0
14	0	0	0	0	0	0	0	0	0
15	∧	∧	∧	∧	∧	∧	∧	∧	∧
16	0	0	0	0	0	0	0	0	0
17	0	0	0	0	0	0	0	0	0
OSC 2 out	8	8	8	8	8	8	8	8	8
21	8	8	8	8	8	8	8	8	8
22	16	16	16	16	16	16	16	16	16
23	0	31	0	0	0	0	0	0	0
24	1	1	1	1	1	1	1	1	1
25	0	0	0	0	0	0	0	0	0
26	0	0	0	0	31	0	0	0	0
VCF output	63	63	32	44	63	63	63	63	63
31	63	63	32	44	63	63	63	63	63
32	0	0	31	31	0	0	0	0	0
33	0	0	0	0	0	0	0	0	0
34	∧	∧	∧	∧	∧	∧	∧	∧	∧
35	0	0	0	0	0	0	0	0	0
VCF attack	0	0	0	0	0	0	0	0	0
41	0	0	0	0	0	0	0	0	0
42	0	0	0	0	0	0	0	0	0
43	0	0	0	0	0	0	0	0	0
44	0	0	0	0	0	0	0	0	0
45	0	0	0	0	0	0	0	0	0
46	0	0	0	0	0	0	0	0	0
47	0	0	0	0	0	0	0	0	0

HELP KEY = (DPN) = H

PROGRAM NO. ADJUST MODE PARAM MEMORY	11 POLY1 13	12 POLY1 23	13 POLY1 31	14 POLY1 31	15 POLY1 26	16 POLY1 72	17 POLY1 72	18 POLY1 71	21 POLY1 73
VCA amp	0	0	0	0	0	0	0	0	0
51	0	0	0	0	0	0	0	0	0
52	0	0	0	0	0	0	0	10	10
53	31	31	31	31	31	31	31	0	0
54	0	0	0	0	0	0	0	0	0
55	31	31	31	31	31	31	31	0	0
56	0	0	0	0	0	0	0	10	10
57	0	0	0	0	0	0	0	0	0
58	∧	∧	∧	∧	∧	∧	∧	∧	∧
59	0	0	0	0	0	0	0	0	0
60	0	0	0	0	0	0	0	0	0
61	∧	∧	∧	∧	∧	∧	∧	∧	∧
62	0	0	0	0	0	0	0	0	0
63	0	0	0	0	0	0	0	0	0
64	0	0	0	0	0	0	0	0	0
65	0	0	0	0	0	0	0	0	0
66	0	0	0	0	0	0	0	0	0
67	off	off	off	off	off	off	off	off	off
68	0	0	0	0	0	0	0	0	0
69	0	0	0	0	0	0	0	0	0
70	0	0	0	0	0	0	0	0	0
71	0	0	0	0	0	0	0	3	0
72	0	0	0	0	0	0	15	0	0
73	0	0	0	0	0	0	0	15	15
74	0	0	0	0	0	0	0	0	0
75	0	0	0	0	0	0	0	0	0
76	0	0	0	0	0	15	15	15	15
77	0	0	0	0	0	0	0	0	0
78	0	0	0	0	0	0	0	0	0
79	0	0	0	0	0	0	0	0	0
80	0	0	0	0	0	0	0	0	0
81	0	0	0	0	0	0	0	0	0
82	0	0	0	0	0	0	0	0	0
83	0	0	0	0	0	0	0	0	0

**Caution:**

- 1) This product has been thoroughly adjusted at the factory before shipment. Therefore never turn any Semi Fixed VRs other than those required for servicing.
- 2) After turning on power, wait at least 15 minutes before beginning test and adjustment.
- 3) Be sure to save the data on tape before loading test data as when loading test data into EX-8000, previous data is erased.

**1. Clearing RAM and Loading Test Data**

- 1) After keeping EX-8000 power on at least 15 minutes, once turn off power and then on pressing number keys [5] and [8].
- 2) Connect to an Amplifier etc. and confirm if there is no sound to check all data of RAM have been erased.
- 3) Load Test Data. (This data is same as DW-8000's one)

\*For convenience, save those chart on tape as Check and Adjustment procedure described below is always made with the data.

**2. D/A converter, CV Check and Adjustment Procedure (KLM-771)**

- 1) Turn off power and then on pressing number keys [5] and [6] at the same time.
- 2) Confirm if UrEF (Voltage reference) is displayed and becomes Test Mode 1.
- 3) Connect a Digital Voltmeter to Test Points: [TP-AG], [TP-REF1] allocated in left side of the board.  
GND side - [TP-AG], +side - [TP-REF1]
- 4) Memorize the value of Digital Voltmeter and then connect as follows.  
+side - [TP-CV]
- 5) Adjust VR1 to obtain the same value as one of +side - [TP-REF1].

Remarks: Adjustment value is in range of 3.29V - 3.64V.

Note: Test Mode 1 cannot be cancelled till being reset. (Power OFF - ON)



### 3. VCA Level Check and Adjustment (KLM-662)

Turn off power and then on pressing number keys [7] and [8] and Test Mode becomes 2.

Oscillating voice is displayed on LED Display with any single key being played under this mode.

**Note:** It must be Test Mode 2 though voice displaying is not required.

- 1) Select Program number 11.
- 2) Connect an Oscilloscope to [TP-SG] (GND side - [TP-AG]) and observe amplitude of output waveform.
- 3) Press C5 key and observe waveform described in Fig. 1.
- 4) Adjust Semi Fixed VRs (VR101 - VR801) of oscillating voice (refer to Voice Display) to obtain waveform of amplitude being 0.7VP-P.

**Remarks:** Allowance of deviation of each voice is under 40mV.

### 4. OSC 2 Level Check and Adjustment (KLM-662)

- 1) Select Program number 12.
- 2) Make same adjustment as VCA Level one.
- 3) Necessary Semi Fixed VRs for adjustment are among VR105 - VR805 of oscillating voice. (refer to Voice Display)

### 5. VCF Resonance Check and Adjustment (KLM-662)

1. Level
- 1) Select Program number 13.
- 2) Connect an Oscilloscope to [TP-SG]. (GND side to [TP-AG])
- 3) Press any single key and confirm amplitude of output waveform of each voice is 0.9VP-P. Unless, adjust Semi Fixed VRs among VR103-VR803 of oscillating voice.

**Remarks:** Allowance of deviation of each voice is under 40mVP-P.

### 2. fo

- 1) Select Program number 13.
- 2) Connect Chromatic Tuner AT-12 to Output Jack of EX-8000.
- 3) Press any single key and confirm oscillation frequency of each voice on AT-12 Display is C (523Hz), 1 octave, 0 cent.
- 4) Unless, adjust Semi Fixed VRs among VR102 - VR802 of oscillating voice.

**Remarks:** Allowance of deviation of each voice is 0 cent  $\pm$  10 cent.

### 3. fc

- 1) Select Program number 14.
- 2) Connect Chromatic Tuner AT-12 to Output Jack of EX-8000.
- 3) Press any single key and confirm oscillation frequency of each voice on AT-12 Display is C (2093Hz), 3 octave, 0 cent.
- 4) Unless, adjust Semi Fixed VRs among VR104 - VR804 of oscillating voice.

**Remarks:** Allowance of deviation of each voice is under 0 cent  $\pm$  10 cent.

### 6. Noise Level Check and Adjustment (KLM-662)

- 1) Select Program number 15.
- 2) Connect a Noise Meter to [TP-SG] (GND side - [TP-AG]).
- 3) Press any single key and confirm value of the meter is -15dbm.
- 4) Unless, adjust VR1 to obtain correct value.

### 7. DWGS Clock Check and Adjustment (KLM-771)

- 1) Connect a Frequency Counter to [TP-CLK] (GND side to [TP-DG]).
- 2) Confirm the counter value is in range of 6.395MHz - 6.405MHz.
- 3) Unless, adjust VR2 to obtain correct value.

### 8. Digital Delay MG-CLK Check and Adjustment (KLM-775)

- 1) Select Program number 16.
- 2) Connect a Frequency Counter to [TP-CLK] (GND side to [TP-AG]).
- 3) Confirm the counter value is 20.0kHz. (Effective with 3 figures only.)
- 4) Unless, adjust VR3 to correct value.
- 5) After 3) is confirmed, select Program number 17.
- 6) Confirm the counter value is in range of 36.0kHz - 43.0kHz.

### 9. Digital Delay Output Waveform Center Position Check and Adjustment (KLM-775)

- 1) Select Program number 17.
- 2) Connect an Oscilloscope to [TP-EXP] (GND side to [TP-AG]). Adjust lit line of the Oscilloscope to 0 volt line of the screen.
- 3) Press C5 key and confirm center of amplitude of output waveform is on 0 volt line of the screen.
- 4) Unless, adjust VR2 to obtain correct position.

### 10. Digital Delay Feed Back Check and Adjustment (KLM-775)

- 1) Select Program number 18.
- 2) Press C5 key and confirm if delayed sound lasts 2 seconds without no ringing.
- 3) Unless, adjust VR1. (Start to ring when turn to the right. Turn to the left and adjustment point is where ringing stops.)
- 4) After 2) is confirmed, select Program number 21.
- 5) Press C5 key and confirm if there is no ringing with delayed sound.

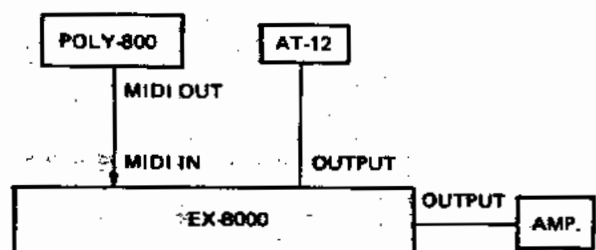

# 9. PARTS LIST

PARTS CODE	PARTS NAME SPECIFICATIONS	P.C. BOARD	IDENTIFICATION NO. FUNCTION	Q'TY
<b>CARBON RESISTORS</b>				
10008000	Y 0Ω	KLM-763		2
10016000	1/8JY 0Ω	KLM-764		7
10016322	1/8JY 220Ω			3
10113747	S1/4JT 4.7M	KLM-771		1
10413147	S1/4JYTP 4.7Ω	KLM-762		1
10413327	S1/4JYTP 270Ω			1
10413347	S1/4JYTP 470Ω			1
10413388	S1/4JYTP 680Ω	KLM-768		18
10413410	S1/4JYTP 1K	KLM-762		4
10413522	S1/4JYTP 22K			1
10416000	1/8JTP 0Ω	KLM-765		5
		KLM-766		14
		KLM-771		3
10416210	1/8JTP 10Ω	KLM-768		2
10416215	1/8JTP 15Ω	KLM-765		1
10416222	1/8JTP 22Ω	KLM-775		2
10416247	1/8JTP 47Ω	KLM-662		11
		KLM-768		1
		KLM-771		2
10416262	1/8JTP 62Ω			1
10416310	1/8JTP 100Ω	KLM-766		4
		KLM-771		3
		KLM-775		4
10416316	1/8JTP 160Ω	KLM-771		2
10416320	1/8JYTP 200Ω	KLM-662		2
10416322	1/8JTP 220Ω			17
10416333	1/8JTP 330Ω	KLM-771		1
10416347	1/8JTP 470Ω	KLM-768		1
10416351	1/8JTP 510Ω	KLM-775		1
10416356	1/8JTP 560Ω	KLM-775		1
10416362	1/8JTP 620Ω	KLM-771		2
10416410	1/8JTP 1.0K	KLM-662		24
		KLM-771		2
		KLM-775		8
10416418	1/8JTP 1.8K	KLM-662		1
		KLM-771		3
		KLM-662		4
10416420	1/8JTP 2.0K			1
10416424	1/8JTP 2.4K			1
10416427	1/8JTP 2.7K			1
10416433	1/8JTP 3.3K	KLM-775		2
10416436	1/8JYTP 3.6K	KLM-771		1
10416447	1/8JTP 4.7K	KLM-662		17
		KLM-765		1
		KLM-771		4
		KLM-775		6

PARTS CODE	PARTS NAME SPECIFICATIONS	P.C. BOARD	IDENTIFICATION NO. FUNCTION	Q'TY
10416451	1/8JTP 5.1K	KLM-662		1
10416456	1/8JTP 5.8K			8
10416462	1/8JTP 6.2K			1
10416468	1/8JTP 6.8K			17
		KLM-775		1
10416475	1/8JTP 7.5K	KLM-662		9
10416491	1/8JTP 9.1K			2
		KLM-775		3
10416510	1/8JTP 10K	KLM-662		12
		KLM-765		1
		KLM-768		2
		KLM-771		23
10416511	1/8JTP 11K	KLM-662		1
		KLM-775		2
10416512	1/8JTP 12K			14
10416513	1/8JTP 13K	KLM-662		1
10416515	1/8JTP 15K	KLM-775		1
10416516	1/8JTP 16K	KLM-662		8
		KLM-771		1
		KLM-775		1
10416518	1/8JTP 18K	KLM-662		8
		KLM-775		5
10416520	1/8JTP 20K			1
10416522	1/8JTP 22K	KLM-662		1
		KLM-768		2
		KLM-775		1
10416527	1/8JTP 27K	KLM-662		16
		KLM-775		10
10416530	1/8JTP 30K	KLM-662		8
		KLM-771		2
10416533	1/8JTP 33K	KLM-662		1
		KLM-771		1
10416539	1/8JTP 39K	KLM-775		1
10416547	1/8JTP 47K	KLM-662		8
		KLM-768		3
10416568	1/8JTP 68K	KLM-662		1
		KLM-771		1
10416610	1/8JTP 100K	KLM-662		2
		KLM-768		2
		KLM-771		1
		KLM-775		8
10416615	1/8JTP 150K	KLM-662		2
		KLM-771		1
10416620	1/8JTP 200K			1
		KLM-775		1
10416622	1/8JTP 220K			2
10416633	1/8JTP 330K	KLM-768		1

PARTS CODE	PARTS NAME SPECIFICATIONS	P.C. BOARD	IDENTIFICATION NO. FUNCTION	Q'TY
10418710	1/8JTP 1.0M	KLM-862 KLM-771 KLM-775		1 2 2
10813322	S1/4JYLC 220Ω	KLM-764		2
10813422	S1/4JYLC 2.2K	KLM767/ 769		1
10813482	S1/4JYLC 8.2K			1
10813610	S1/4JYLC 10K	KLM-764		2
10813610	S1/4JYLC 100K			2
<b>METAL FILM RESISTORS</b>				
12413232	1/4TP 232Ω	KLM-762		1
12414100	1/4TP 1.00K			1
12613402	1/8TP 402Ω	KLM-771		2
12614100	1/8TP 1.00K			2
12614140	1/8TP 1.4K			1
12614174	1/8TP 1.74K			2
12614308	1/8TP 3.09K			2
12614348	1/8TP 3.48K			3
12614422	1/8TP 4.22K			2
12615100	1/8TP 10.0K			4
12615200	1/8TP 20.0K			2
12615267	1/8TP 26.7K			1
12615301	1/8TP 30.1K			1
12615688	1/8TP 69.8K			1
12615732	1/8TP 73.2K			1
<b>BLOCK RESISTORS</b>				
13608522	RKC1/888J 22K	KLM-771		1
13608410	RKC1/888J 1K	KLM-862		2
13608422	RKC1/888J 2.2K	KLM-771		1
13608610	RKC1/888J 10K	KLM-862		1
13608622	RKC1/888J 22K	KLM-771		3
13807002	RNBQEL001A	KLM-775		1
13807003	RKC4L263	KLM-771		1
<b>THERMISTORS</b>				
18032310	TD6-A110DA	KLM-771		1
18032410	TD6-C210DA	KLM-862		1
18032450	TD6-C260DA			2
<b>MYLAR CAPACITORS</b>				
20402410	50V 0.001μF	KLM-862		32

PARTS CODE	PARTS NAME SPECIFICATIONS	P.C. BOARD	IDENTIFICATION NO. FUNCTION	Q'TY
		KLM-771 KLM-775 KLM-862		2 1 18
20402415	50V 0.0015μF			1
20402418	50V 0.0018μF			1
20402422	50V 0.0022μF	KLM-775		2
20402427	50V 0.0027μF			2
20402456	50V 0.0056μF			2
20402510	50V 0.01μF	KLM-771 KLM-775		1 1
20402512	50V 0.012μF	KLM-771		1
20402522	50V 0.022μF	KLM-775		3
20402527	50V 0.027μF	KLM-862		1
20402547	50V 0.047μF			18
		KLM-766 KLM-771		2 2
<b>STYROL CAPACITORS</b>				
20502247	50V GT 47pF	KLM-771		2
20503256	50V JT 56pF	KLM-775		1
<b>CERAMIC CAPACITORS</b>				
21452220	50V 22pF TP	KLM-771		4
21452330	50V 33pF TP			1
21452470	50V 47pF TP			1
21453100	50V 100pF TP			2
		KLM-775		2
21453151	50V 150pF TP	KLM-771		2
21453220	50V 220pF TP	KLM-775		3
21453330	50V 330pF TP	KLM-766		2
		KLM-775		3
21453470	50V 470pF TP	KLM-862		1
		KLM-765		1
		KLM-775		2
21453680	50V 680pF TP			2
21455100	50V 0.01μF TP	KLM-762 KLM-765		2 3
		KLM-766		2
		KLM-771		1
21455470	50V 0.047μF TP	KLM-862		29
		KLM-771		67
		KLM-775		22
21456100	25V 0.1μF TP	KLM-862		8
		KLM-762		11
		KLM-766		2



PARTS CODE	PARTS NAME SPECIFICATIONS	P.C. BOARD	IDENTIFICATION NO. FUNCTION	Q'TY
<b>EMI FILTERS</b>				
21860100	D8S310-55D2238	KLM-771 KLM-775		3 2
<b>ELECTROLYTIC CAPACITORS</b>				
23811410	25V 1000 $\mu$ F	KLM-762		1
23911447	25V 4700 $\mu$ F			1
23911468	25V 8800 $\mu$ F			1
25403210	18V 10 $\mu$ F	KLM-862 KLM-768 KLM-771 KLM-775		4 1 8 9
25403222	16V 22 $\mu$ F	KLM-782 KLM-768 KLM-771		1 1 1
25403247	18V 47 $\mu$ F	KLM-762 KLM-768		1 3
25403310	18V 100 $\mu$ F	KLM-862 KLM-782 KLM-768 KLM-775		2 3 2 3
25404147	25V 4.7 $\mu$ F	KLM-762 KLM-768		1 2
25404247	25V 47 $\mu$ F	KLM-762		1
25408022	50V 0.22 $\mu$ F	KLM-775		2
25408110	50V 1 $\mu$ F	KLM-862 KLM-768 KLM-771		7 2 1
25408122	50V 2.2 $\mu$ F	KLM-775 KLM-771		1 1
25443247	18V 47 $\mu$ F	KLM-775		8
25448010	50V 0.1 $\mu$ F	KLM-862		1
25448022	50V 0.22 $\mu$ F			8
25483210	18V 10 $\mu$ F			10
25468110	50V 1 $\mu$ F	KLM-775		3 4
<b>TRANSISTORS</b>				
30100328	2SB744 A P/Q	KLM-762		1
30202299	2SC2785 K SELECTED (Silver)	KLM-862		1
30400020	2SA1175 K TN	KLM-762		2
30400050	2SA1175	KLM-862		18

PARTS CODE	PARTS NAME SPECIFICATIONS	P.C. BOARD	IDENTIFICATION NO. FUNCTION	Q'TY
30420070	2SC2785	KLM-771 KLM-775 KLM-862 KLM-768 KLM-771		1 3 2 3 2
30420090	2SC2901 T ALL			2
<b>DIGITAL TRANSISTORS</b>				
30430010	DTA-114N	KLM-771		2
30430020	DTC-114N	KLM-775 KLM-771		1 1
<b>FETs</b>				
30480020	2SK381-34-B	KLM-775		2
<b>DIODES</b>				
31001500	SR1K-2	KLM-762		11
31400300	1S-2473			2
31401300	1SS-133	KLM-768 KLM-768 KLM-771 KLM-775		21 3 6 6
<b>BRIDGE DIODE</b>				
31010200	4B4B41	KLM-762		1
<b>LEDs</b>				
31203200	LN624RA	KLM-768		3
31206100	SLP-178B			1
31410100	LT-8201P	KLM-762		1
<b>ICs</b>				
32001023	$\mu$ PD-4066BC	KLM-862 KLM-771 KLM-775	Analog switch	4 1 1
32001061	$\mu$ PD-4050BC	KLM-771	Hex buffer	1
32001062	$\mu$ PD-4051BC	KLM-862 KLM-771	Analog multiplexer	3 1
32001085	$\mu$ PD65010CW-113	KLM-775	Gate array	1
32001087	$\mu$ PC319C		Comparator	1
32001090	$\mu$ PC311C	KLM-775	Comparator	1

PARTS CODE	PARTS NAME SPECIFICATIONS	P.C. BOARD	IDENTIFICATION NO. FUNCTION	Q'TY
32002100	74HC00	KLM-771	NAND gate	1
32002102	74HC04		Hex inverter	2
32002187	74HC(40H)374		D-type flip-flop	4
32003070	TC9154P	KLM-775	Tone control	1
32004028	HM-6116LP-4	KLM-771	RAM	2
32004084	HA17008P		D/A	1
32004085	HD63803X		CPU	1
32004086	HN613256PT-70		ROM	1
32004087	HN613256PT-71		ROM	1
32004088	HN613256PC84		ROM	1
32004089	HN613256PC85		ROM	1
32004095	HN4827128G-25		ROM	1
32004097	74HC240		Buffer	1
32009005	NJM-4558 S	KLM-662	OP AMP	4
		KLM-775		5
32009011	NJM-7805 A	KLM-762	Power regulator +5V	3
32009018	NJM-2903 D	KLM-771	Comparator	1
32009021	NJM-7905A	KLM-762	Power regulator -5V	1
32009035	NJM5534-D	KLM-771	OP AMP	1
32009036	NJM2069A-D	KLM-662	VCF + VCA	8
32009037	DAC-08 EDC	KLM-771	D/A	1
32011007	M-74LS74		Dual D-type positive-edge-triggered flip-flop	1
32011008	M-74LS139		Dual 2-line to 4-line decoders	1
32011014	M 74LS138	KLM-662	3-line to 8-line decoders	2
32011016	M-74LS374	KLM-771	Octal D-type edge-triggered flip-flop	2
32011020	M5224P	KLM-662	OP AMP	6
32011024	M-5223	KLM-771	OP AMP	1
32011026	M-54513P		Inverter	1
32011028	M-5216 L	KLM-768	OP AMP	1
32011042	M54562P	KLM-771	TR array	1
32011044	M74LS175	KLM-662	Quad D-type flip-flop	1
32011045	M74LS244P	KLM-771	Octal buffer	2
32011047	M5218P	KLM-662	OP AMP	4
		KLM-771		3
		KLM-775		3
32011048	M5221P	KLM-662	OP AMP	8
		KLM-771		3
		KLM-775		1
32011061	M53206P	KLM-771	Hex Inverter	1
32011064	M5M4416P	KLM-775	TTL RAM	2
32012008	MB62H133	KLM-771	Gate array	1
32012009	MB64H129		Gate array	1
32021047	SN74S189		TTL RAM	10
32021104	74HC20N		NAND gate	1
32021108	74HC32N		OR gate	3

PARTS CODE	PARTS NAME SPECIFICATIONS	P.C. BOARD	IDENTIFICATION NO. FUNCTION	Q'TY
32021115	74HC(40H)138N	KLM-771	Decoder	1
32023005	S-8054HN		Reset	1
32025003	NE572N	KLM-775	Compressor/Expander	1
<b>PHOTO COUPLER</b>				
33001000	TLP-552	KLM-771		1
<b>CERAMIC OSCILLATOR</b>				
33501800	KBR-8.0MHz	KLM-771		1
<b>P.C. BOARD WITH PARTS</b>				
34068200	KLM-662	KLM-662		1
34076200	KLM-762	KLM-762		1
34076300	KLM-763	KLM-763		1
34076400	KLM-764/767/769	KLM-764		1
34076500	KLM-765/K766/768	KLM-765		1
34077100	KLM-771	KLM-771		1
34077500	KLM-775	KLM-775		1
<b>SEMI FIXED VRs</b>				
35001247	H0651A 4.7KB	KLM-775		1
35001315	H0651A 15KB			2
35002210	RH0615C 1K	KLM-771		1
35002268	PH0615C 6.8K	KLM-662		8
		KLM-771		1
35002315	RH0615C 15K	KLM-662		8
35002322	RH0615C 22K			8
35002333	RH0615C 33K			16
35002510	RH0615C 1M			1
<b>VRs</b>				
36019300	RK1631110R80A 10KB	KLM-769		1
36019400	RK1631120A3EA 10KB	KLM-766		1
36205000	RK1631220A0EA 10KB X 2			1
<b>SLIDE SWs</b>				
37301000	SSB-122019	KLM767/769		3
37305300	SLS-25-2022-1	KLM-764		1

45

PARTS CODE	PARTS NAME SPECIFICATIONS	P.C. BOARD	IDENTIFICATION NO. FUNCTION	QTY
46411901	250 0.8A UL		117 2P 100V 220 GE 220 SE 240 AF 240 AU DEMKO SEMKO NEMKO 240 GE GAF FIMKO 240 RME VDE	1
<b>HARNESSES</b>				
4705434	HNS-434	KLM-768		1
4705360	HNS-435			1
4705380	HNS-436			1
4705370	HNS-437			1
4705380	HNS-438			1
4705390	HNS-439			1
4705400	HNS-440			1
4705410	HNS-441			1
4705420	HNS-442			1
4705430	HNS-443			1
4705440	HNS-444			1
4705450	HNS-445			1
4705460	HNS-446			1
4705470	HNS-447			1
4705480	HNS-448			1
4705490	HNS-449			1
<b>CONNECTORS</b>				
47150300	83P-VH	KLM-662		1
47150600	88P-VH	KLM-762 KLM-763 KLM-762		1
47170400	84B-PH	KLM-771 KLM-762		1
47170900	88B-PH	KLM-764 KLM-662		1
47170900	88B-PH	KLM-662 KLM-771		1
47170900	88B-PH	KLM-764 KLM-662		1
47170900	88B-PH	KLM-662		1

PARTS CODE	PARTS NAME SPECIFICATIONS	P.C. BOARD	IDENTIFICATION NO. FUNCTION	QTY
37507800	ESB-8213V		100V 117 US 117 2P 220 GE 220 SE 240 AF 240 AU DEMKO SEMKO NEMKO 240 GE GAF FIMKO 240 RME VDE JAM	1
<b>POWER SW.</b>				
37504800	KEC-10010	KLM-768		13
37504800	KEC-11903			6
<b>FACT SW.</b>				
40009200	TC-015A			1
<b>POWER TRANSFORMER</b>				
40202300	BL02RHZ-R62	KLM-764 KLM-765		1
<b>COILS</b>				
<b>RELAY</b>				
40300700	GSA237P 9V	KLM-766		1
<b>PHONE JACKS</b>				
45404400	YKB21-5010	KLM-764 KLM-765		2
45404500	YKB21-5028			2
<b>FUSES</b>				
46411901	250V 630MA UL		117 US JAM	1

PARTS CODE	PARTS NAME SPECIFICATIONS	P.C. BOARD	IDENTIFICATION NO. FUNCTION	Q'TY
47170800	B9B-PH	KLM-771		1
47171000	B10B-PH	KLM-862		1
47171300	B13B-PH	KLM-771		1
47171500	B15B-PH			1
47270300	S3B-PH	KLM-765		1
		KLM767/ 769		1
		KLM-769		1
47270400	S4B-PH	KLM-766		1
		KLM-766		2
		KLM767/ 769		2
		KLM-775		1
47270600	S5B-PH			1
47270600	S6B-PH			1
47270700	S7B-PH	KLM-766		1
47270800	S8B-PH			1
<b>IC SOCKET</b>				
48001282	28P DICA-28CTI	KLM-771		1
<b>DIN JACK SOCKET</b>				
48010180	(X3) M-1704	KLM-764		1
<b>RUBBER FEET</b>				
60008700				4
<b>FUSE HOLDERS</b>				
61502300	S-N5057 #01	KLM-763		2
<b>LITHIC BATTERY</b>				
62001300	CR2032-FT			1
<b>TEST PINS</b>				
64007100	LC-2-G-YELLOW	KLM-862		2
		KLM-771		5
		KLM-775		3

PARTS CODE	PARTS NAME SPECIFICATIONS	P.C. BOARD	IDENTIFICATION NO. FUNCTION	Q'TY
<b>WIRE BANDS</b>				
54007200	PLT-1M	KLM-862		9 2
<b>ISOLATING WASHERS</b>				
54007300	B-1725K	KLM-762		4
<b>SPIRAL CLIPS</b>				
54008600	CS-8			2
<b>INLET SOCKET</b>				
54010900	PA-126			1
<b>DKN CLUMPS</b>				
54011500	DKN-10			4
<b>SPACERS</b>				
54011600	A-2241			2
54011800	PS-303	KLM-768		1
<b>SLIDE SW MASKS</b>				
55005400				3
<b>RADIATOR</b>				
56003300		KLM-762		1
<b>RADIATION SHEETS</b>				
56500300	BFG-30	KLM-762		4
<b>AC CORDS</b>				
60002100	SPT-2 UC-695-S01		117 US 117 2P	1 1
60002200	CEE EC-215-S01		220 GE 240 AF DEMKO SEMKO NEMKO	1 1 1 1 1



PARTS CODE	PARTS NAME SPECIFICATIONS	P.C. BOARD	IDENTIFICATION NO. FUNCTION	Q'TY
			240 GE	1
			GAF	1
			FIMKO	1
			VDE	1
60002300	SAA 3C-455-S01		240 AU	1
60002400	DC-325-S01		100V	1
60002500	88 BH-115-S01		240 RME	1
60002600	CSA UC-707-S01		JAM	1
60002900	SE EX-221-S01		220 SE	1
<b>SYNC/MIDI CABLE</b>				
60202400	SMC-3 BLK			1
<b>SLIDE SW KNOBS</b>				
62001800	SSB L-9 BLK			3
<b>TACT SW KNOBS</b>				
62011000	KT-8			6
62011202	RED			1
62015100	BLK NO.4			12
<b>POWER SW KNOB</b>				
62011100	SUE58102			1
<b>ROTARY VR KNOBS</b>				
62016200	GRY NO.2			3
<b>SHIELDING SHEETS</b>				
63001800				1
63002800				1
<b>LED DISPLAY COVER</b>				
63002100				1
<b>METAL FITTINGS OF P.C. BOARD</b>				
64072500	A			2
64072800	B			2

PARTS CODE	PARTS NAME SPECIFICATIONS	P.C. BOARD	IDENTIFICATION NO. FUNCTION	Q'TY
<b>PANEL</b>				
64072900				1
<b>FRONT CHASSIS</b>				
64073000				1
<b>UPPER CASE</b>				
54073100				1
<b>LOWER CASE</b>				
64073200				1
<b>RACK MOUNT ADAPTORS</b>				
64073300				2
<b>NAME PLATES</b>				
68600700			117 US 117 2P	1 1
<b>SCREWS</b>				
70060512	FE P BZMC 5 X 12			4
70160410	FE F BZMC 4 X 10			6
70630308	FE B ZMC 3 X 6			28
70630308	FE B ZMC 3 X 8	KLM-762		4
70760410	FE FEW BZMC 4 X 10			4
72160308	TP2G F BZMC 3 X 8			2
72560308	TP2G B BZMC 3 X 8			17
72730308	TP2G FEW ZMC 3 X 8	KLM-762		2
				12
<b>NUTS</b>				
77330700	VN ZMC 7			3
<b>WASHERS</b>				
78060500	WM BZMC 5 X 12			4

PARTS CODE	PARTS NAME SPECIFICATIONS	P.C. BOARD	IDENTIFICATION NO. FUNCTION	Q'TY
<b>SPRING NUTS</b>				
79060400	ZMC 4			4