

# ALESIS MICRON (Q02) Service Manual

P/N: 8-31-0147-A

## **ATTENTION!**

THIS DOCUMENT CONTAINS SENSITIVE  
PROPRIETARY INFORMATION.  
ALL RECIPIENTS MUST HAVE A CURRENT  
NON-DISCLOSURE AGREEMENT ON FILE  
WITH ALESIS, LLC.

**DO NOT MAKE ILLEGAL  
COPIES OF THIS DOCUMENT**

The information in this document contains privileged and confidential information. It is intended only for the use of those authorized by Alesis. If you are not the authorized, intended recipient, you are hereby notified that any review, dissemination, distribution or duplication of this document is strictly prohibited. If you are not authorized, please contact Alesis and destroy all copies of this document. You may contact Alesis at [servicemanuals@alesis.com](mailto:servicemanuals@alesis.com) or at [support@alesis.com](mailto:support@alesis.com).

Copyright © 2004 Alesis, LLC

## **Preface**

This document is intended to assist the service technician in the operation, maintenance and repair of the Alesis device. Together with the User Reference Manual, this document provides a complete description of the functionality and serviceability of the Device. Any comments or suggestions you may have pertaining to the document are welcome and encouraged.

### **READ THIS!**

In addition to any purchase price that Alesis may charge as consideration for Alesis selling or otherwise transferring this service manual ("Manual") to you, if you are not a service and repair facility ("Service Center") authorized by Alesis in writing to be an authorized Service Center, Alesis sells or transfers the Manual to you on the following terms and conditions:

Only Service Centers authorized by Alesis in writing are authorized to perform service and repairs covered by an Alesis warranty (if any), and transfer of the Manual to you does not authorize you to be an authorized Service Center. **Therefore, if you perform, or if the Manual is used to perform, any service or repairs on any Alesis product or part thereof, any and all warranties of Alesis as to that product and any service contract with Alesis for that product shall be voided and shall no longer apply for such product, even if your services or repairs were done in accordance with the Manual.**

All service or repairs done by you or with reference to the Manual shall be solely your responsibility, and Alesis shall have no liability for any such repairs or service work. **All such service or repairs are performed at the sole risk of the person performing the service or repairs.** You agree that all such work will be performed in a competent, professional and safe manner at all times and to indemnify and fully hold Alesis and its successors and assigns harmless in the event of any failure to so perform.

Your purchase of the Manual shall be for your own ultimate use and shall not be for purposes of resale or other transfer.

As the owner of the copyright to the Manual, Alesis does not give you the right to copy the Manual, and you agree not to copy the Manual without the written authorization of Alesis. Alesis has no obligation to provide to you any correction of, or supplement to, the Manual, or any new or superseding version thereof.

Alesis shall have the right to refuse to sell or otherwise transfer repair parts or materials to you in its sole discretion. You shall not use, sell or otherwise transfer spare or replacement parts supplied by Alesis to you (i) to repair or be used in products manufactured for or by third parties or (ii) to any third parties for any purpose.

You shall not make any warranties or guarantees with respect to the products of Alesis or the use thereof on behalf of Alesis or in your own name.

The foregoing describes the entire understanding related to sale or transfer of the Manual to you, and no other terms shall apply unless in a writing signed by an authorized representative of Alesis.

All Trademarks are property of their respective companies.

## ***Warnings***

**TO REDUCE THE RISK OF ELECTRIC SHOCK OR FIRE, DO NOT EXPOSE THIS PRODUCT TO WATER OR MOISTURE.**



The arrowhead symbol on a lightning flash inside a triangle is intended to alert the user to the presence of un-insulated "dangerous voltage" within the enclosed product which may be of sufficient magnitude to constitute a risk of electric shock to persons.



The exclamation point inside a triangle is intended to alert the user to the presence of important operating, maintenance and servicing instructions in the literature which accompanies the product.

**REPAIR BY ANY PERSON OR ENTITY OTHER THAN AN AUTHORIZED ALESIS SERVICE CENTER WILL VOID THE ALESIS WARRANTY.**

**PROVISION OF THIS MANUAL DOES NOT AUTHORIZE THE RECIPIENT TO COMPETE WITH ANY ALESIS DISTRIBUTOR OR AUTHORIZED REPAIR SERVICE CENTER IN THE PROVISION OF REPAIR SERVICES OR TO BE OR MAKE REPAIRS AS AN AUTHORIZED SERVICE CENTER.**

**ALL REPAIRS DONE BY ANY ENTITY OTHER THAN AN AUTHORIZED ALESIS SERVICE CENTER SHALL BE SOLELY THE RESPONSIBILITY OF THAT ENTITY, AND ALESIS SHALL HAVE NO LIABILITY TO THAT ENTITY OR TO ANY OTHER PARTY FOR ANY REPAIRS BY THAT ENTITY.**

### ***Regarding the Power Supply Fuse***



**CAUTION:** The product under service may employ the use of a replaceable fuse. Danger of fire or electrocution if fuse is incorrectly replaced. Replace with only the same type or equivalent type recommended by the equipment manufacturer.

### ***Regarding the Internal Battery***



**CAUTION:** The product under service may employ the use of an internal battery. Danger of explosion if battery is incorrectly replaced. Replace only with the same or equivalent type recommended by the manufacturer. Dispose of used batteries according to the manufacturer's instruction.

## ***Safety Instructions***

Carefully read the applicable items of the operating instructions and these safety suggestions before using this product. Use extra care to follow the warnings written on the product itself and in the operating instructions. Keep the operating instructions and safety suggestions for reference in the future.

1. Power Source. The product should only be connected to a power supply which is described either in the operating instructions or in markings on the product.
2. Power Cord Protection. AC power supply cords should be placed such that no one is likely to step on the cords and such that nothing will be placed on or against them.
3. Periods of Non-use. If the product is not used for any significant period of time, the product's AC power supply cord should be unplugged from the AC outlet.
4. Foreign Objects and Liquids. Take care not to allow liquids to spill or objects to fall into any openings of the product.
5. Water or Moisture. The product should not be used near any water or in moisture.
6. Heat. Do not place the product near heat sources such as stoves, heat registers, radiators or other heat producing equipment.
7. Ventilation. When installing the product, make sure that the product has adequate ventilation. Improperly ventilating the product may cause overheating, which may damage the product.
8. Mounting. The product should only be used with a rack which the manufacturer recommends. The combination of the product and rack should be moved carefully. Quick movements, excessive force or uneven surfaces may overturn the combination which may damage the product and rack combination.
9. Cleaning. The product should only be cleaned as the manufacturer recommends.
10. Service. The user should only attempt the limited service or upkeep specifically described in the operating instructions for the user. For any other service required, the product should be taken to an authorized service center as described in the operating instructions.
11. Damage to the Product. Qualified service personnel should service the unit in certain situations including without limitation when:
  - a. Liquid has spilled or objects have fallen into the product,
  - b. The product is exposed to water or excessive moisture,
  - c. The AC power supply plug or cord is damaged,
  - d. The product shows an inappropriate change in performance or does not operate normally, or
  - e. The enclosure of the product has been damaged.

# SERVICE MANUAL

MODEL:Q02

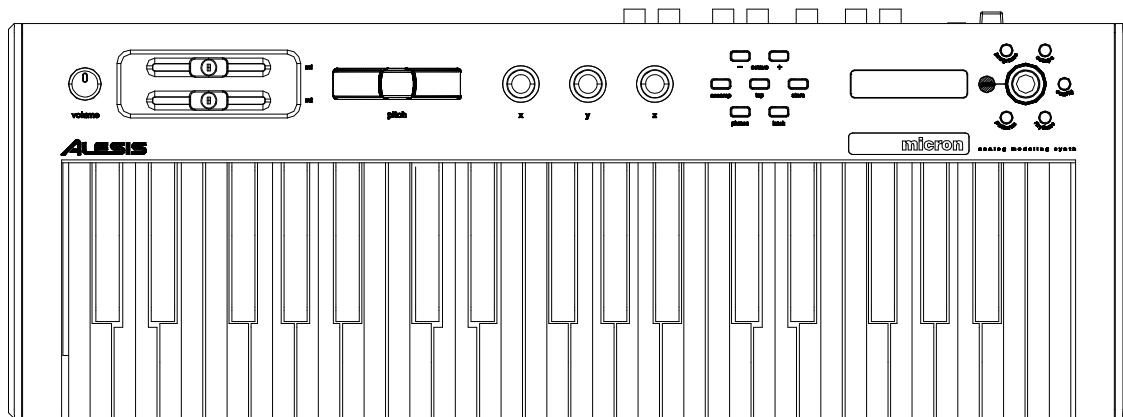

## Specifications

### Sound Engine

Sound Generation:

Alesis proprietary DSP Analog Modeling

Polyphonic Voices:

8, each with 3 oscillators, 2 multi-mode filters, 3 envelope generators, 2 LFOs, programmable effects send and modulation matrix.

Program Memory:

512 Preset Programs, 32 Multi-timbral Setups, all user-rewritable

Effects:

4 Drive Effects (1 each per Part) plus Master Effects (Shared)

### Audio Input

Input Connectors: 2 Balanced 1/4" TRS jacks

Maximum Input Level: +5.2dBu (1.41VRMS) = -0dBFS

Input Impedance: 10k

### Audio Output

Output Connectors: 4 Impedance-Balanced 1/4" TRS jacks, 1/4" TRS Headphone Jack

Maximum Output Level: +18dBu (6.17 VRMS) = -0dBFS

Output Impedance: 1k

### Audio Performance

Signal To Noise Ratio: >95 dB A-weighted, Ext In to Main or Aux Out

THD+N: < 0.005%, External In to Main or Aux Out

Frequency Response: 20-20kHz  $\pm$ 0.20dB, External In to Main or Aux Out

Power Consumption: 12 Watts max (100-240VAC/50-60Hz)

### Physical

Keyboard: 37 keys (velocity, release velocity sensitive)

Real-Time Controllers: 3 360-degree Parameter Knobs, 2 Assignable Modulation Sliders, Assignable Pitch Wheel,

Pedal Jacks: Assignable Exp pedal jack, Sustain pedal jack

MIDI Connections: MIDI In, MIDI Out, MIDI Thru

Audio Outputs: Main L/R, Aux L/R, Headphone (1/4" TRS)

Dimensions (WxHxD): 22.75" x 2.75" x 7.75" / 577.85 x 69.85 x 196.85 mm

Weight: 8.25 lbs / 3.5 kg

### Volume

The (volume) knob on the far left-hand side of the Micron raises and lowers

the volume. If you don't hear anything as you play the Micron, suspect the (volume) knob's setting.

### Real-time controllers

The (m1) and (m2) sliders, (pitch) wheel, and (x/y/z) knobs, located on the left half of the Micron, provide real-time control of the Micron's sounds.

### Performance buttons

The buttons in this cluster switch octaves, set the tempo, and perform other performance-related functions.

# ALESIS MICRON (Q02) COMPONENTS

## **Display**

Information relevant to the current operation is shown here.

## **Control knob circle**

These are the Micron's most important controls – the control knob and the buttons that surround it. Pressing one of these buttons – [programs], [setups], [config], [patterns], or [rhythms] – puts you into one of the Micron's primary modes of operation. Turning the control knob then cycles through options. Pressing the control knob allows for editing.

## **Key concepts**

Here are the Micron's most important concepts:

### **Programs**

Programs are the Micron's sounds, built from its oscillators, envelopes, filters, modulation matrix, and other analog-style components.

### **Rhythms**

Rhythms are combinations of drum programs with patterns. Think of a drum machine with its interchangeable sounds and patterns. That's pretty close to what rhythms are.

### **Patterns**

Patterns are repeating melodic and/or rhythmic motifs. Arpeggios and step sequences are examples of patterns.

### **Setups**

Setups combine multiple programs, rhythms, patterns, and more. They are the Micron's most powerful and most sonically sophisticated element.

## **Navigating with the transparent control knob and its buttons**

Use the transparent control knob to the right of the display and its surrounding circle of buttons to navigate through the Micron's options. Most Micron functions involve pressing the buttons and then turning or pushing this knob.

### **Green Light/Red Light**

The buttons circling the control knob glow green when selected and glow red when the control knob has been pushed (entering edit mode).

The exception is the [config] button. [config] only glows red, since it only performs editing functions.

At any one time, only one of the buttons will glow, indicating that the Micron is operating within that mode.

### **Turn**

Turn the control knob to cycle through various options.

### **Push**

Push the control knob to edit the option displayed. Push again to stop editing.

# DISASSEMBLY PROCEDURES

## 1. REMOVAL OF TOP AND BOTTOM PANEL (Fig.1)

- (A) TAKE OUT THE 8 PCS SCREW FIXING THE KEYBED FROM WHICH THE BOTTOM CHASSIS
- (B) TAKE OUT THE 7 PCS NUT OF 1/4 " CONNECTORS FROM TOP PANEL
- (C) TAKE OUT THE 16 PCS SCREW FROM WHICH THE BOTTOM PANEL

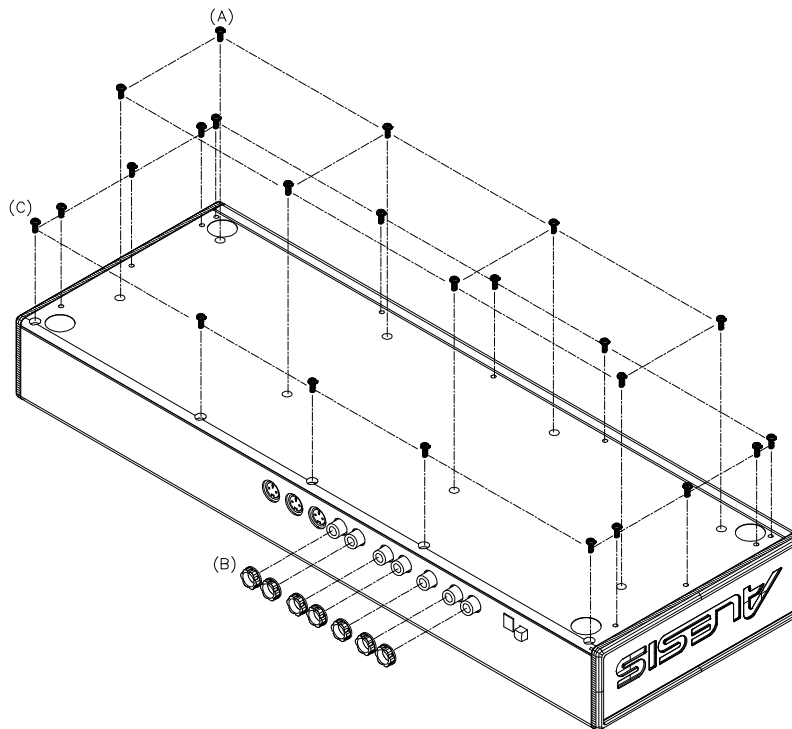

(Fig.1)

## 2. REMOVAL OF MAIN PCB AND LED PCB (Fig.2)

- (A) REMOVAL THE 2 PCS SCREW FROM WHICH LED PCB
- (B) REMOVAL THE 6 PCS SCREW FROM WHICH MAIN PCB
- (C) REMOVAL THE 8 PCS OF CABLE CONNECTORS FROM MAIN PCB

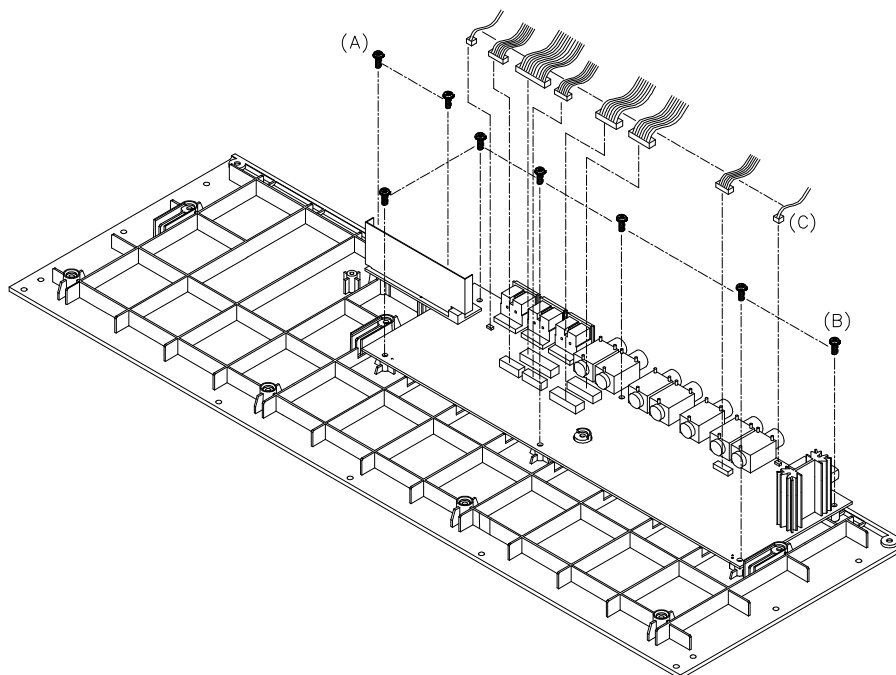

(Fig.2)



### 3. REMOVAL OF ASSY PCB (Fig.3)

- (A) REMOVAL THE 3 PCS SCREW FROM THE TOP PANEL RIGHT PCB
- (B) REMOVAL THE 4 PCS SCREW FROM THE LCD PCB
- (C) REMOVAL THE 6 PCS SCREW FROM THE TOP PANEL CENTER PCB
- (D) REMOVAL THE 4 PCS SCREW FROM THE TOP PANEL LEFT PCB
- (E) REMOVAL THE 2 PCS SCREW FROM THE ASSY PITCH WHEEL

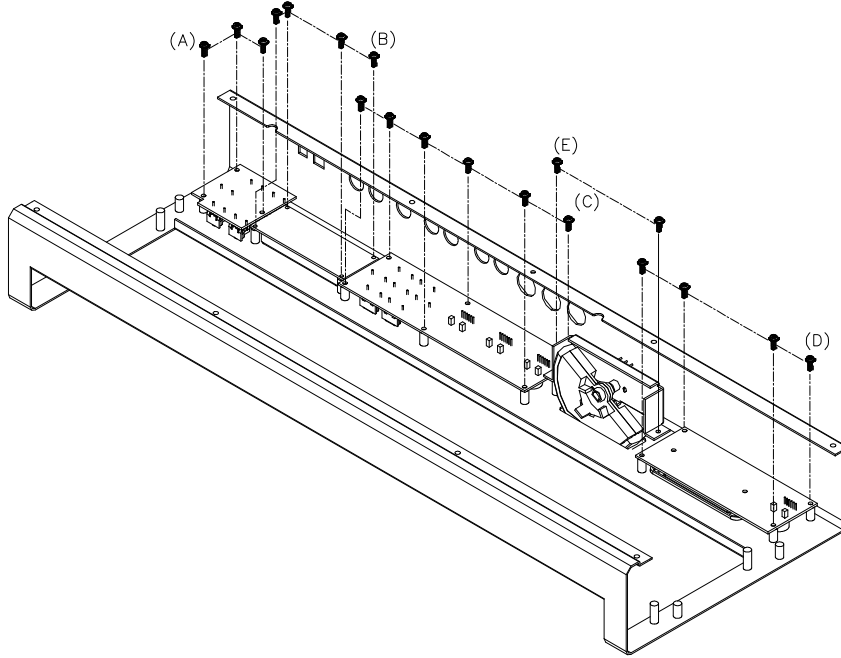

(Fig.3)

# WIRING DIAGRAM

## (US/EU/UK/AUS NZ)

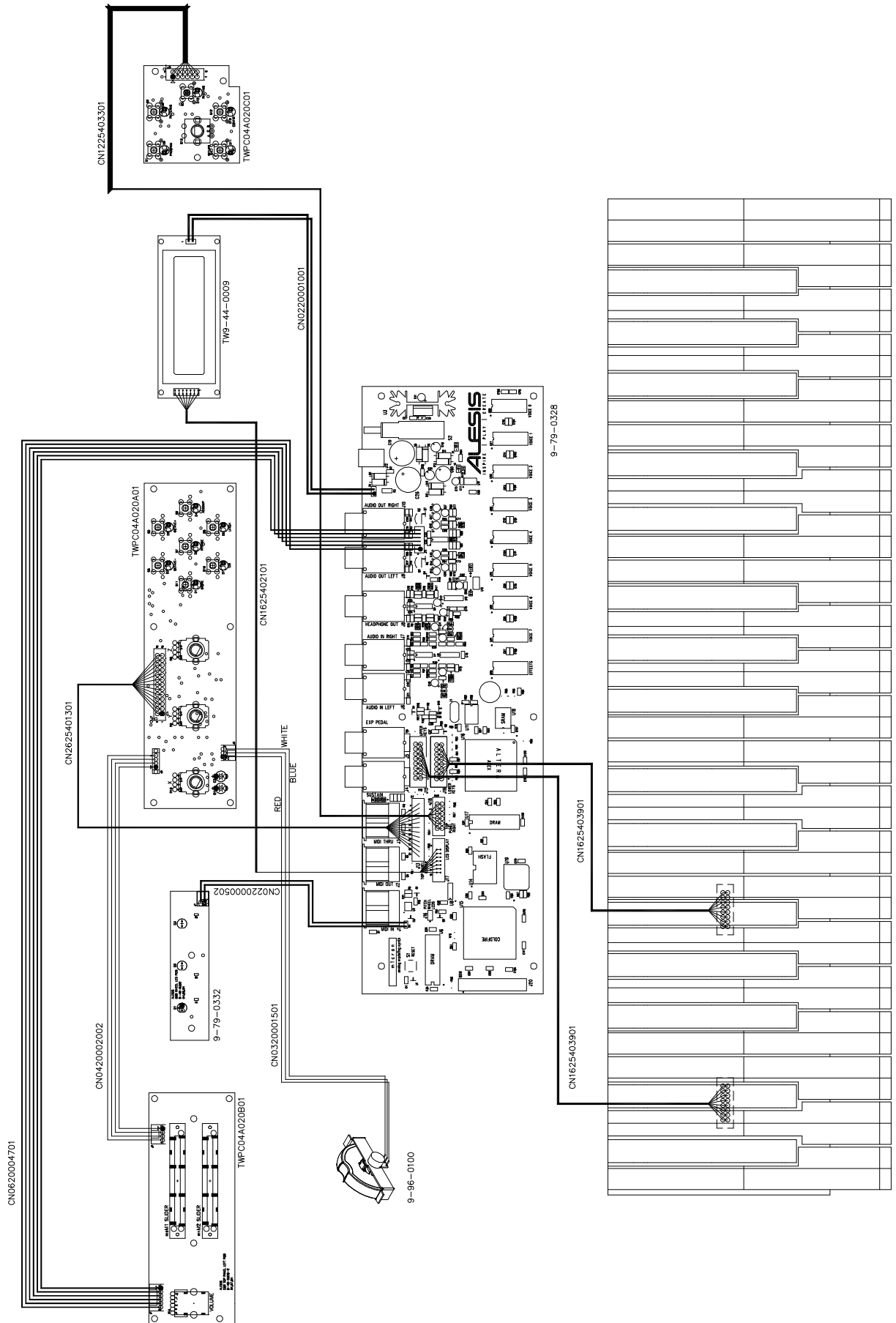

# PACKING DIAGRAM

(US/EU/UK/AUS NZ)

TRANSFORMER  
7-40-0903

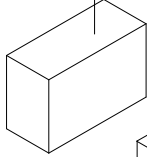

ENDCAP FOAM LEFT  
PUQ0201

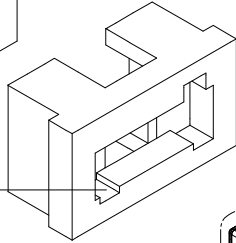

GEL SILICA  
7-91-1002

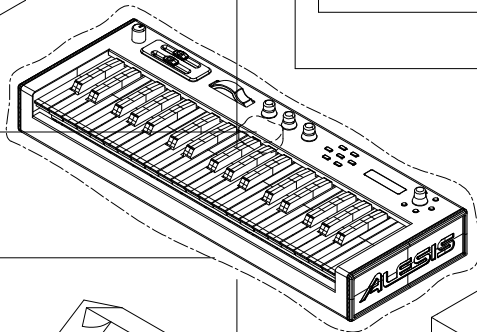

BAG FOAM  
SD68035000

MANUAL REFERENCE  
7-51-0166

PE BAG

PE150350B0

SAFTY GUIDE

7-51-0154

QUICK START REFERENCE

7-51-0182

WELCOME SHEET

7-51-1219

WRITE PROTECT

7-51-1279

ENDCAP FOAM RIGHT  
PUQ0202

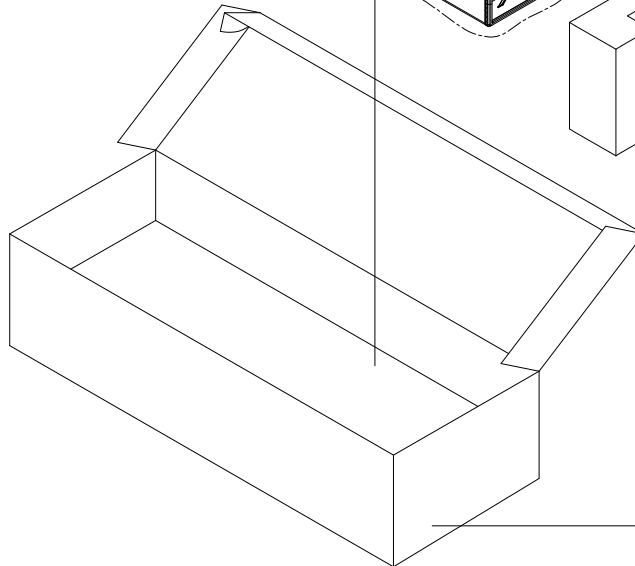
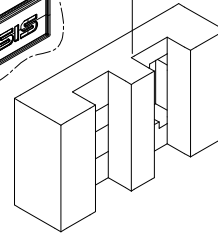

INNER BOX  
CGQ02310ALE01

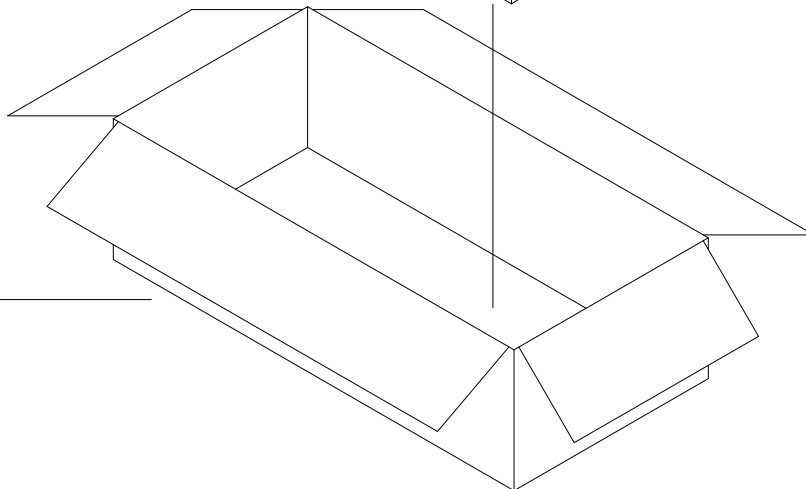

CARTON  
CTQ02513ALE01

# EXPLODE DIAGRAM

(US/EU/UK/AUS NZ)

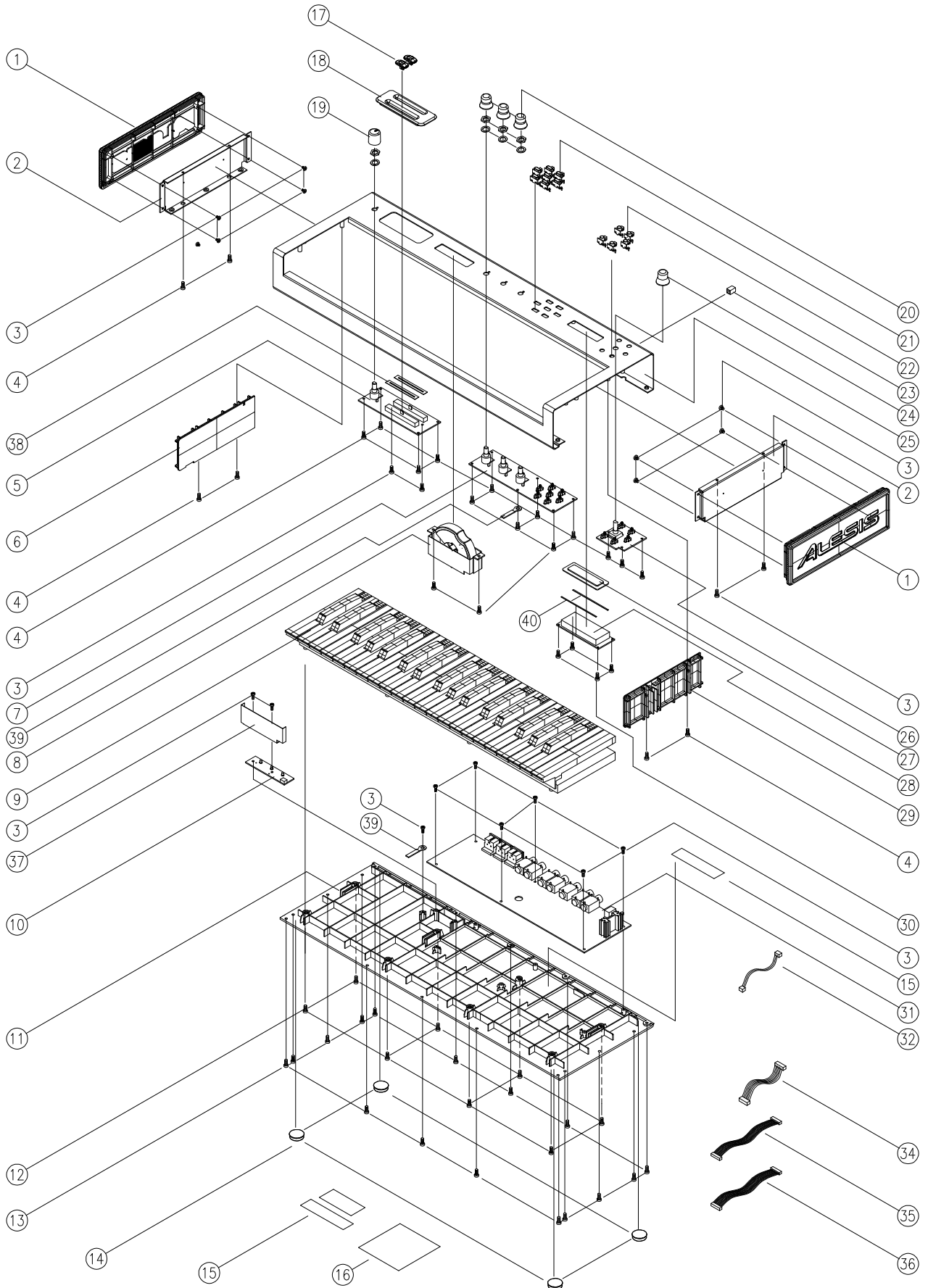

SEQUENTIAL NO OF EXPLODE DIAGRAM WILL BE MARKED ON REF. COLUMNM OF BOM LIST

# ALESIS MICRON (Q02)

## BOM

## Q02 BOM

LEVEL	P/N	DESCRIPTION	QTY	REF
1	PT130442401	FIXED HOLDER	2	1
1	MT1304449	FIXED METAL	2	2
1	SC0308RBZI	SCREW	19	3
1	SC0306RICI	SCREW	23	4
1	9-15-0307	END CAP LEFT	1	6
1	7-10-0122	KEYBED 37 KEYS	1	9
1	PT133030401	BOTTOM CHASSIS	1	11
1	SC0310RBZI	SCREW	8	12
1	SC3506AICI	SCREW	16	13
1	BAAR-034	PU STAND	4	14
1	LAC22ALE27	STICKER BARCODE S/N	1	15
1	PT131067101	CAP FADER	2	17
1	PT130442301	FIXED HOLDER	1	18
1	9-15-0304	KNOB VOLUME	1	19
1	9-15-0303	KNOB	3	20
1	PT131064501	BUTTIN	7	21
1	PT131063601	BUTTIN	5	22
1	BAPS-W010	SWITCH CAP	1	23
1	PT1310675	KNOB	1	24
1	9-01-0082	FRONT PANEL	1	25
1	9-10-0065	LENS LCD	1	27
1	9-15-0308	END CAP RIGHT	1	29
1	SC2606RINI	SCREW	4	30
1	CN0220000502	CONNECTOR	1	32
1	CN0620004701	CONNECTOR	1	34
1	CN1625402101	CONNECTOR	1	35
1	CN1625403901	CONNECTOR	2	36
1	PT1304711	INSULATOR SHEET	1	37
1	NM1106112	VELVET CARPET	2	38
1	BAGL-70L	CLIP	1	39
1	EVA1304408	EVA	2	40
1	TF57023201UL	TRANSFORMER	1	
1	PQ02ALE01	PACK	1	
2	LAC52ALE01	LABEL	1	16
2	7-51-1219	SHEET	1	
2	CTQ02513ALE01	CARTON	1	
2	CGQ02310ALE01	INNER CARTON	1	
2	PUQ0201	FOAM	1	
2	PUQ0202	FOAM	1	
2	7-91-1002	GEL SILICA	1	
2	PE150350BO	POLYBAG	0.01	
2	SD68035000	SOFT SHEET	1	
2	7-51-0166	INSTRUCTION BOOK	1	
2	7-51-0182	QUICK START MANUAL	1	
2	7-51-0154	OPERATION MANUAL	1	
2	7-51-1279	MANUAL REFERENCE PV	1	
1	LAP67YAH255	LABEL	4	
<b>1</b>	<b>TW9-44-0009</b>	<b>LCM組品</b>	<b>1</b>	<b>28</b>
2	CN0220001001	單頭聯結器(2P 100MM)	1	
2	4-14-0016	雙排排針16P 254 180	1	
2	9-44-0009	LCM	1	
<b>1</b>	<b>9-96-0100</b>	<b>PITCH WHEEL組品</b>	<b>1</b>	<b>8</b>
2	CN0320001501	連結器(3P 150MM)	1	
2	MT1304412	轉輪固定鐵片	1	
2	WS1306505	華司	1	
2	0-09-0037	可變電阻5KB	1	
2	7-13-0080	熱縮套管1/16"X5/8"	2	
2	9-06-0030	彈簧	1	

## Q02 BOM

LEVEL	P/N	DESCRIPTION	QTY	REF
2	9-15-0301	PITCH MOD轉輪	1	
<b>1</b>	<b>TWPC04A02001</b>	<b>FRONT PANEL PCB ASS'Y</b>	<b>1</b>	
2	PC04A020	FRONT PANEL PCB	1	
2	TWPC04A020A01	FRONT PANEL PCB ASS'Y	1	7
3	CN0420002002	4P CONNECTOR (200mm)	1	J5
3	CN2625401301	26P CONNECTOR (130mm)	1	J7
3	PC04A020A	FRONT PANEL PCB	1	
3	TE622000302	3P CONNECTOR	1	(J6)
3	TE812000411	4P CONNECTOR	1	(J5)
3	0-09-0044	VR 2.5KB	3	R8~10
3	0-16-2002	RESISTOR 20K (SMD)1%	1	R5
3	0-17-0103	RESISTOR 4x10K 1/16W	3	R3,4,6
3	0-17-0331	RESISTOR 4x330O 1/16W	2	R1,2
3	1-08-0222	ELECT 22UF/16V	2	C3,4
3	1-08-0223	ELECT 220UF/16V	1	C13
3	1-56-0102	CERAMIC 1000P (SMD)	1	C6
3	1-56-0104	CERAMIC 0.1UF (SMD)	14	C1,2,5,7~12,14~18
3	2-51-4401	TRANSISTOR 2N4401	5	Q1~4,28
3	2-51-4403	TRANSISTOR 2N4403	2	Q10,16
3	2-62-0595	IC 74HC595	1	U1
3	2-72-0339	IC LM339	1	U4
3	2-72-4051	IC CD4051	1	U3
3	3-02-0049	RED LED	7	D1~7
3	6-02-0050	SWITCH	7	S5~11
<b>2</b>	<b>TWPC04A020B01</b>	<b>LEFT PANEL PCB ASS'Y</b>	<b>1</b>	<b>5</b>
3	PC04A020B	LEFT PANEL PCB	1	
3	RS15218J05	RESISTOR 1K5 (SMD)	2	R160,170
3	TE10200602	6P HEADER	1	J1
3	TE622000401	4P HEADER	1	J3
3	0-09-0046	VR 10KA	1	R13
3	0-09-1038	VR 10KB	2	R11,12
3	1-56-0104	CERAMIC 0.1UF (SMD)	4	C11,12,19,20
<b>2</b>	<b>TWPC04A020C01</b>	<b>RIGHT PANEL PCB ASS'Y</b>	<b>1</b>	<b>26</b>
3	CN1225403301	12P CONNECTOR (330mm)	1	J2
3	PC04A020C	RIGHT PANEL PCB	1	
3	RS75018J05	RESISTOR 75O (SMD)	1	R14
3	1-56-0104	CERAMIC 0.1UF (SMD)	1	C2
3	2-62-0595	IC 74HC595	1	U2
3	3-03-0001	LED (TR1-STATE)	5	D8~12
3	6-00-0008	ENCODER	1	S13
3	6-02-0050	SWITCH	5	S1~4,12
<b>1</b>	<b>9-79-0328</b>	<b>MAIN PCB ASS'Y</b>	<b>1</b>	<b>31</b>
2	DIN4002	DIODE	8	D1,2,5,8,11~14
2	JKDJ-0702B-025	JACK	1	J12
2	MT1303215	HEATSINK	1	(U3)
2	NUT0103IZI	NUT	1	(U3)
2	RS10118J05	RESISTOR 100O (SMD)	4	R83,87,88,89
2	RS10218J05	RESISTOR 1K (SMD)	17	R3,11~14,23~27,35,41~44,51,78
2	RS10318J05	RESISTOR 10K (SMD)	8	R1,5,37~39,45,48,84
2	RS10418J05	RESISTOR 100K (SMD)	13	R17~22,28~32,81,82
2	RS18218J05	RESISTOR 1K8 (SMD)	4	R36,40,52,53
2	RS20318J05	RESISTOR 20K (SMD)	4	R54,55,74,75
2	RS30218J05	RESISTOR 3K (SMD)	4	R67,68,73,76
2	RS51118J05	RESISTOR 510O (SMD)	2	R15,50
2	RS91218J05	RESISTOR 9K1 (SMD)	4	R66,69,72,77
2	R45001	RESISTOR 45O 1W	1	R2

## Q02 BOM

LEVEL	P/N	DESCRIPTION	QTY	REF
2	TE10200601	6P CONNECTOR	1	J14
2	TE612000202	2P CONNECTOR	2	J11,16
2	WS073307IC	WASHER	2	(U3)
2	0-05-1399	RESISTOR 3.90	2	R91,92
2	0-16-2210	RESISTOR 2210 (SMD)1%	10	R4,9,10,46,47,65,71,79,80,83
2	0-16-3650	RESISTOR 3650 (SMD)1%	1	R94
2	0-17-0103	RESISTOR 4x10K 1/16W	8	R7,8,16,33,34,56,64,70
2	0-17-0221	RESISTOR 4x220O 1/16W	8	R49,57~63
2	0-17-0470	RESISTOR 4x47O 1/16W	4	R6,85,86,90
2	1-08-0222	ELECT 22UF/16V	17	C31,40~48,51,54~57,75,76
2	1-08-0228	ELECT 2200UF/16V	2	C10,26
2	1-08-0333	ELECT 330UF/16V	1	C60
2	1-12-0102	ELECT 10UF/63V	2	C34,49
2	1-55-0561	CERAMIC 560P	14	C11~20,52,53,73,74
2	1-56-0104	CERAMIC 0.1UF	78	C1~4,9,21~25,27~30,32,33,35~39,50,61,64~72,77~122
2	1-56-0151	CERAMIC 150P	4	C58,59,62,63
2	1-56-0221	CERAMIC 220P	4	C5~8
2	2-05-0111	TRANSISTOR J111	2	Q2,3
2	2-11-1317	IC LM317	1	U3
2	2-27-0060	IC AL3201	1	U11
2	2-50-4149	DIODE	6	D3,4,6,7,9,10
2	2-51-4401	TRANSISTOR 2N4401	2	Q1,6
2	2-51-4403	TRANSISTOR 2N4403	2	Q4,5
2	2-61-2417	IC LM1117	1	U12
2	2-61-7807	IC LM340MP	1	U13
2	2-62-0014	IC 74AHC14	1	U8
2	2-66-6256	IC DRAM 256K	2	U6,17
2	2-67-6257	IC SRAM 32K	1	U18
2	2-70-5206	IC MCF5206E	1	U15
2	2-71-0084	IC TL084	2	U4,7
2	2-71-3079	IC MC33079	1	U5
2	2-74-0181	IC TLP181	1	U2
2	2-75-1101	IC AL1101	1	U9
2	2-75-1201	IC AL1201	1	U10
2	2-77-0096	IC AL3101	9	U20~28
2	2-79-1818	IC DS1818	1	U1
2	2-80-0007	IC	1	U16
2	4-00-0002	5P MIDI	3	J1~3
2	4-02-0007	7P JACK	7	J4~10
2	4-14-0012	12P HEADER	1	J18
2	4-14-0016	16P HEADER	1	J17
2	4-14-0116	16P HEADER	2	J15,19
2	4-14-2601	26P HEADER	1	J13
2	5-03-0028	STANDOFF	1	(U3)
2	6-02-0003	SWITCH	1	S2
2	7-01-0024	CRYSTAL 12.288MHz	1	X1
2	7-01-0035	OSCILLATOR 54MHz	1	U19
2	9-40-0328	MAIN PCB	1	
2	9-61-0121	IC	1	U14
<b>1</b>	<b>9-79-0332</b>	<b>LED PCB ASS'Y</b>	<b>1</b>	<b>10</b>
2	R10116	RESISTOR 100O 1/16W	3	R1~3
2	TE622000201	2P CONNECTOR	1	J1
2	3-02-0049	RED LED	3	D1~3
2	9-40-0332	LED PCB	1	



# ALESIS MICRON (Q02) QC PROCEDURES

## Q02 QC Test Procedures

### Items required for test (one each unless otherwise specified):

- Q02 unit with current OS
- 9VAC, 1.5A power adapter
- MIDI cable
- Sustain pedal
- Pair of headphones
- AP Computer w/ cables

### Setup

- 1) Connect power adapter to power outlet and to Q02.
- 2) Connect the MIDI cable from Q02 MIDI OUT to Q02 MIDI IN.
- 3) Plug the headphones into the **headphones** output jack of the Q02. Turn **Master Volume** knob (red knob) completely CCW.
- 4) Power up Q02 while holding down [**Octave -**] and [**Octave +**] buttons. This brings the Q02 into diagnostic mode. Verify that the text "**Push enc to test**" appears on the first line of the LCD.

### Visual Inspection

- 1) Inspect the front panel for dents and scratches.
- 2) Make sure that the end caps are properly seated into the chassis. Verify that they also don't have any dents any scratches.
- 3) Verify that all the jacks on the rear of the Q02 have nuts installed.

### Pitch wheel LEDs

- 1) Verify that the pitch wheel lights up red. The light should get bright and dim in a cycle.

### Expression Pedal Test

- 1) Plug the sustain pedal into the "**expr**" **input** jack of the Q02.
- 2) Press on the sustain pedal and verify that the LCD displays the text "Exp pedal: 0".
- 3) Release the sustain pedal and verify that the LCD now displays the text "Exp pedal: 16383"
- 4) Plug the sustain pedal into the "**sustain**" **input** jack of the Q02.

## Audio Output Test

- 1) While listening to the headphones, press a key and turn the **Master Volume** knob clockwise until the sound is at a comfortable listening level (this verifies that the **Master Volume** pot is functional). Verify that both the left and right sides of the headphones produce a sound.
- 2) Plug the headphones into the Q02 audio output **left** jack. Verify that when a key is pressed, a sound is heard on one side (left side) of the headphones.  
NOTE: the **Master Volume** knob may require adjustment in order to hear this sound more easily.
- 3) Repeat step 2) for the Q02 audio output **right** jack. The sound should again be heard on the left side of the headphones.

## Audio Output Test

- 1) Plug the headphones into the Q02 headphone output jack (**Master Volume** knob may require readjustment to bring headphone output to a comfortable listening level).
- 2) Press and hold down a key (do not release). A single sound should be heard from the headphones.
- 3) Press and hold a second key (do not release the first key) and verify that a second sound is heard together with the first one.
- 4) Press and hold a third key (do not release the first and second key) and verify that a third sound is heard together with the first and second ones.
- 5) Repeat step 4) five more times, so that a total of eight notes are playing simultaneously, each time verifying that the new note is heard along with the existing notes that are already playing.

## External Audio Input

- 1) Hold down the **[phrase]** and **[latch]** buttons together. Verify that the second line of the LCD says "**Audio in -> out**". Release the buttons.
- 2) Connect the AP generator output to the Q02 audio input left.
- 3) Set the AP generator output to produce a 2Vp, 1KHz sinewave and turn on the output.
- 4) Verify that there is a sound from the left side of the headphones
- 5) Connect the AP generator output to the Q02 audio input right and verify that there is a sound from the right side of the headphones.

## AP Test

- 1) Unplug the headphones from the Q02 headphones jack.
- 2) Turn the **Master Volume** knob completely clockwise.
- 3) Connect the AP generator outputs A and B to the Q02 audio in left and right, respectively.
- 4) Connect the Q02 main output left and right to the AP analyzer inputs A and B, respectively.
- 5) Run the AP tests (SNR, THD+N, and frequency response).
- 6) Hold down the **[phrase]** and **[latch]** buttons together. Verify that the second line of the LCD says "**Synth -> audio out**". Release the buttons.

## Automated Tests

The system will provide a series of tests must be passed. Before beginning, verify that the sustain pedal is plugged into the "**sustain**" input jack.

## PUSH THE ENCODER TO BEGIN AUTOMATED TESTS.

Each test is described below. The title of each section should appear on the first line of the LCD.

### Push all buttons.

- 1) Verify that the first line of the LCD says "Push all buttons".
- 2) There are **7 rectangular** buttons to the left of the LCD. Push each one. Verify that the button lights **red** when it is pushed, and stays red for the remainder of the test.
- 3) There are **5 round** buttons to the right of the LCD. Push each one. Verify that the button lights **green** when it is pushed, and lights red when it is released. When a different round button is pushed, the light should turn off. There should never be more than one round button lit.
- 4) When any button is pressed down, verify that the name of that button is displayed on the LCD, and that the LCD indicates the button is pressed down with the text "**[button]** down."
- 5) When any button is released, verify that the LCD indicates the button has been released with the text "**[button]** up."
- 6) As each button is pressed, make sure that the silk screen on that button is not scratched or misaligned. Also verify that all the buttons have a consistent feel, and that they generate one "click" when pressed.
- 7) When all 12 buttons have been pushed, you will automatically go to the next test.

## **Press all keys.**

- 1) Verify that the first line of the LCD says "Press all keys".
- 2) When a key pressed, verify that the LCD says "**Key ## down**", where ## is the key number. The leftmost key is number 0, and the rightmost key is number 36.
- 3) When a key is released, verify that the LCD says "**Key ## up**", where ## is the same key number.
- 4) As each key is pressed, make sure that the key movement and feel is consistent with all the other keys. Inspect the keys as well for scratches and dents.
- 5) When all 37 keys have been pressed, you will automatically go to the next test.

## **Turn p wheel -->**

- 1) Verify that the first line of the LCD says "Turn p wheel -->".
- 2) Turn the pitch wheel completely to the **right**.

## **Turn p wheel <--**

- 1) Verify that the first line of the LCD says "Turn p wheel <--".
- 2) Turn the pitch wheel completely to the **left**.

## **Slide m1 -->**

- 1) Verify that the first line of the LCD says "Slide m1 -->".
- 2) Slide the m1 slider completely to the **right**.

## **Slide m1 <--**

- 1) Verify that the first line of the LCD says "Slide m1 <--".
- 2) Slide the m1 slider completely to the **left**.

## **Slide m2 -->**

- 1) Verify that the first line of the LCD says "Slide m2 -->".
- 2) Slide the m2 slider completely to the **right**.

## **Slide m2 <--**

- 1) Verify that the first line of the LCD says "Slide m2 <--".
- 2) Slide the m2 slider completely to the **left**.

### **Turn knob x -->**

- 1) Verify that the first line of the LCD says "Turn knob x -->".
- 2) Turn knob x to the **right** until the number passes 1500.
- 3) Verify that the turning is smooth. **If the number jumps around, the unit does not pass.**
- 4) Also verify that there are no bumps or rough spots felt on the pot knob as it is turned.

### **Turn knob x <--**

- 1) Verify that the first line of the LCD says "Turn knob x <--".
- 2) Turn knob x to the **left** until the number passes -1500.
- 3) Verify smoothness as described above.

### **Turn knob y -->**

- 1) Verify that the first line of the LCD says "Turn knob y -->".
- 2) Turn knob y to the **right** until the number passes 1500.
- 3) Verify smoothness as described above.

### **Turn knob y <--**

- 1) Verify that the first line of the LCD says "Turn knob y <--".
- 2) Turn knob y to the **left** until the number passes -1500.
- 3) Verify smoothness as described above.

### **Turn knob z -->**

- 1) Verify that the first line of the LCD says "Turn knob z -->".
- 2) Turn knob z to the **right** until the number passes 1500.
- 3) Verify smoothness as described above.

### **Turn knob z <--**

- 1) Verify that the first line of the LCD says "Turn knob z <--".
- 2) Turn knob z to the **left** until the number passes -1500.
- 3) Verify smoothness as described above.

### **Turn enc -->**

- 1) Verify that the first line of the LCD says "Turn enc -->".
- 2) Turn the encoder to the **right** until the number passes 200.

### **Turn enc <--**

- 1) Verify that the first line of the LCD says "Turn enc <--".
- 2) Turn the encoder to the **left** until the number passes -200.

### **Push sus pedal.**

- 1) Verify that the first line of the LCD says "Push sus pedal"..
- 2) Verify that the sustain pedal is plugged into the **sustain** jack, and push and release the sustain pedal.

### **Push: MIDI loop.**

- 1) Verify that the first line of the LCD says "Push: MIDI loop".
- 2) Verify that the MIDI in jack is connected to the MIDI out jack with a MIDI cable.
- 3) Push the encoder to test the connection.

### **Tests passed.**

- 1) Verify that the first line of the LCD says "\* Tests passed".

## **END OF QC TEST PROCEDURES**

### **Firmware Update**

To update firmware, power on the system while holding down the **[programs]** and **[setups]** buttons. Connect a PC to the MIDI in jack, and send a sysex file.

# ALESIS MICRON (Q02)

# SCHEMATIC AND PCB FILES



6

5

4

3

2

1

REVISION RECORD			
LTR	ECO NO:	APPROVED:	DATE:

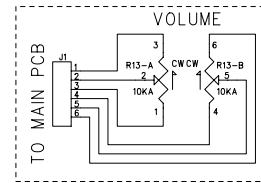
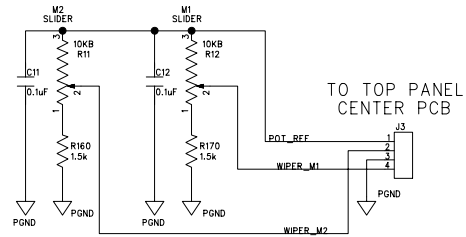

D

D

C

C

B

B

A

A

COMPANY:		ALESIS	
TITLE:			
Q02 TOP PANEL LEFT PCB			
PART NUMBER:		9-40-0329-2	REV: 2
ASSY NUMBER:		9-79-0329	
FILENAME:		Q02TL200a.sch	SIZE: C
SCALE:		SHEET: 1 OF 1	

DRAWN:	B.Victor	DATED:	1/20/04
RELEASED:		DATED:	

5

4

3

2

1

REVISION RECORD			
LTR	ECO NO:	APPROVED:	DATE:

### SWITCHES

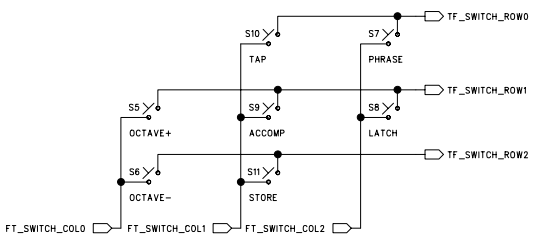

Use a split ground plane.  
GND and PGND should not be connected on the PCB.

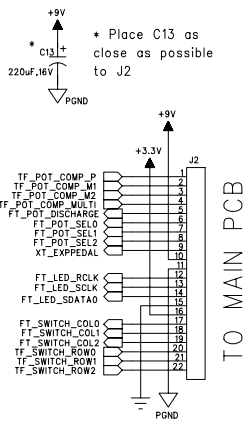

### LEDS

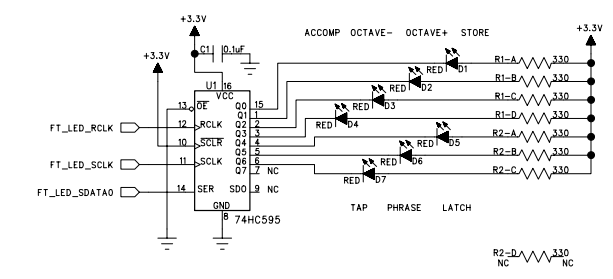

### POTS

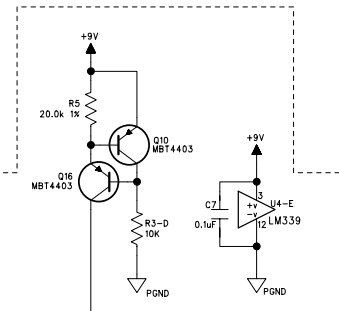

\* Place C8-C10 as close as possible to their respective dual pots (i.e. place C8 as close as possible to R8).  
\*\* Place C2, C11, C12, C14, C15, C16 as close as possible to U3.

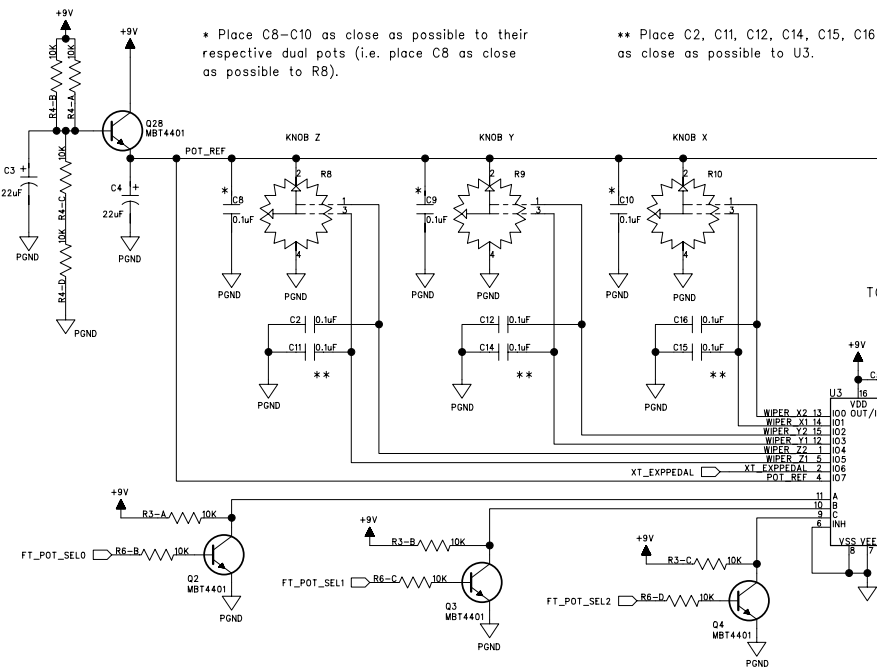

COMPANY:		<b>ALESIS</b>	
TITLE:			
Q02 TOP PANEL CENTER PCB			
PART NUMBER:	9-40-0347-3	REV:	2
ASSY NUMBER:	9-79-0347	FILENAME:	Q02TC300a.sch
SCALE:		SHEET:	1 OF 1

DRAWN:	B.Victor	DATED:	2/17/04
RELEASED:		DATED:	

D  
C  
B  
A

D  
C  
B  
A

6

5

4

3

2

1

D

D

C

C

B

B

A

A

REVISION RECORD			
LTR	ECO NO:	APPROVED:	DATE:

### SWITCHES

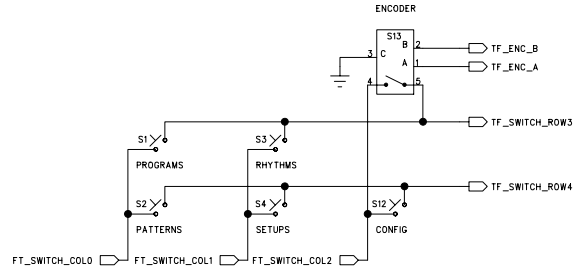

### LEDS

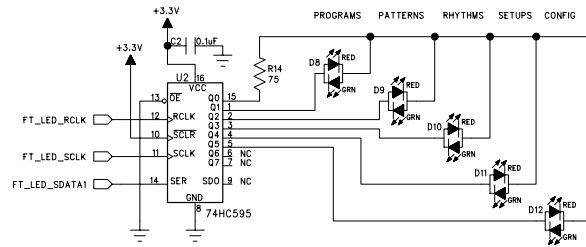

TO MAIN PCB

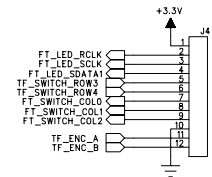

COMPANY:		ALESIS	
TITLE:			
Q02 TOP PANEL RIGHT PCB			
PART NUMBER:	9-40-0348-2	REV:	1
ASSY NUMBER:	9-79-0348		
FILENAME:	Q02TR200a.sch	SIZE:	C
SCALE:		SHEET: 1	OF 1

DRAWN:	B.Victor	DATED:	1/20/04
RELEASED:		DATED:	

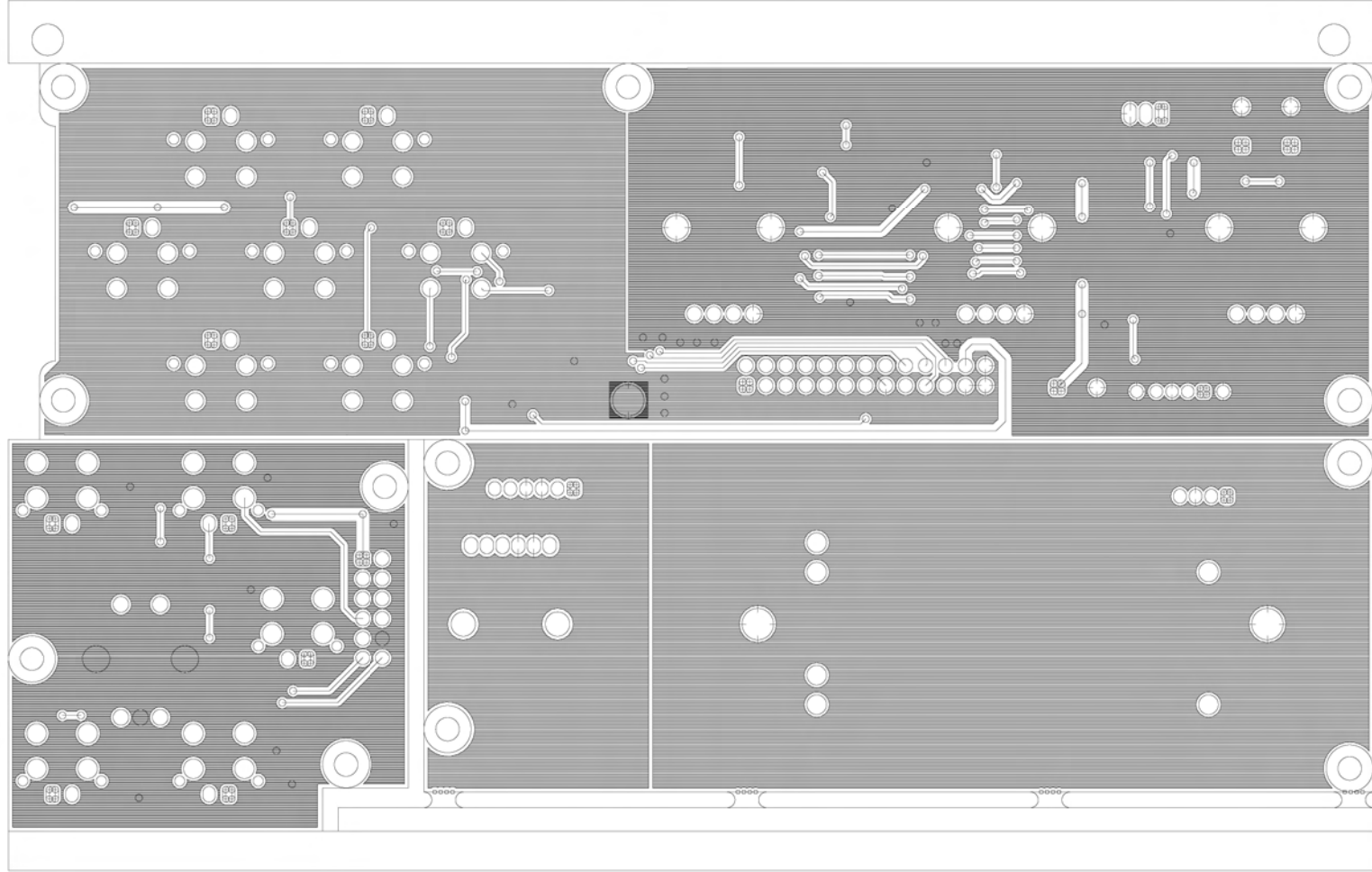

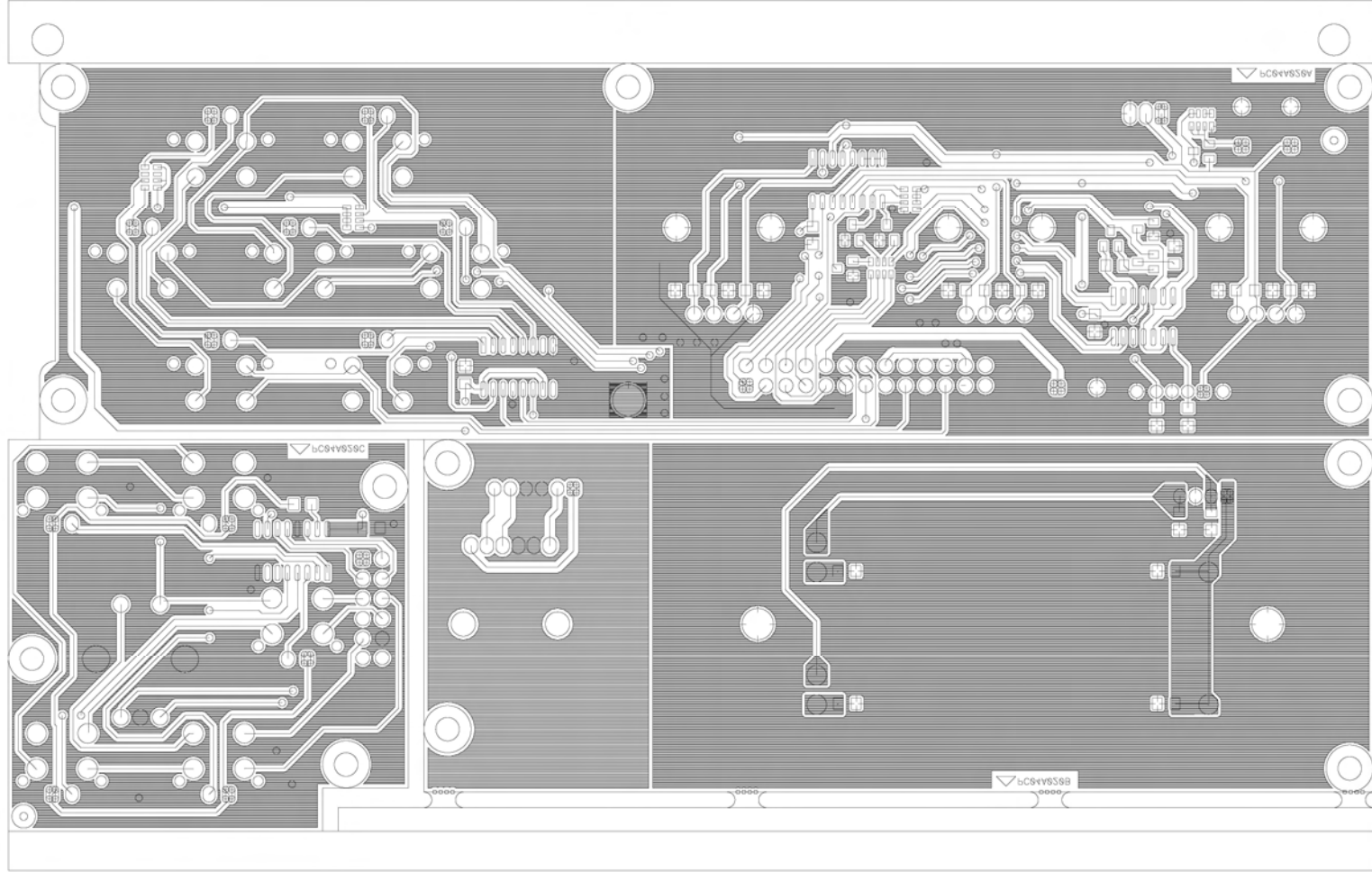

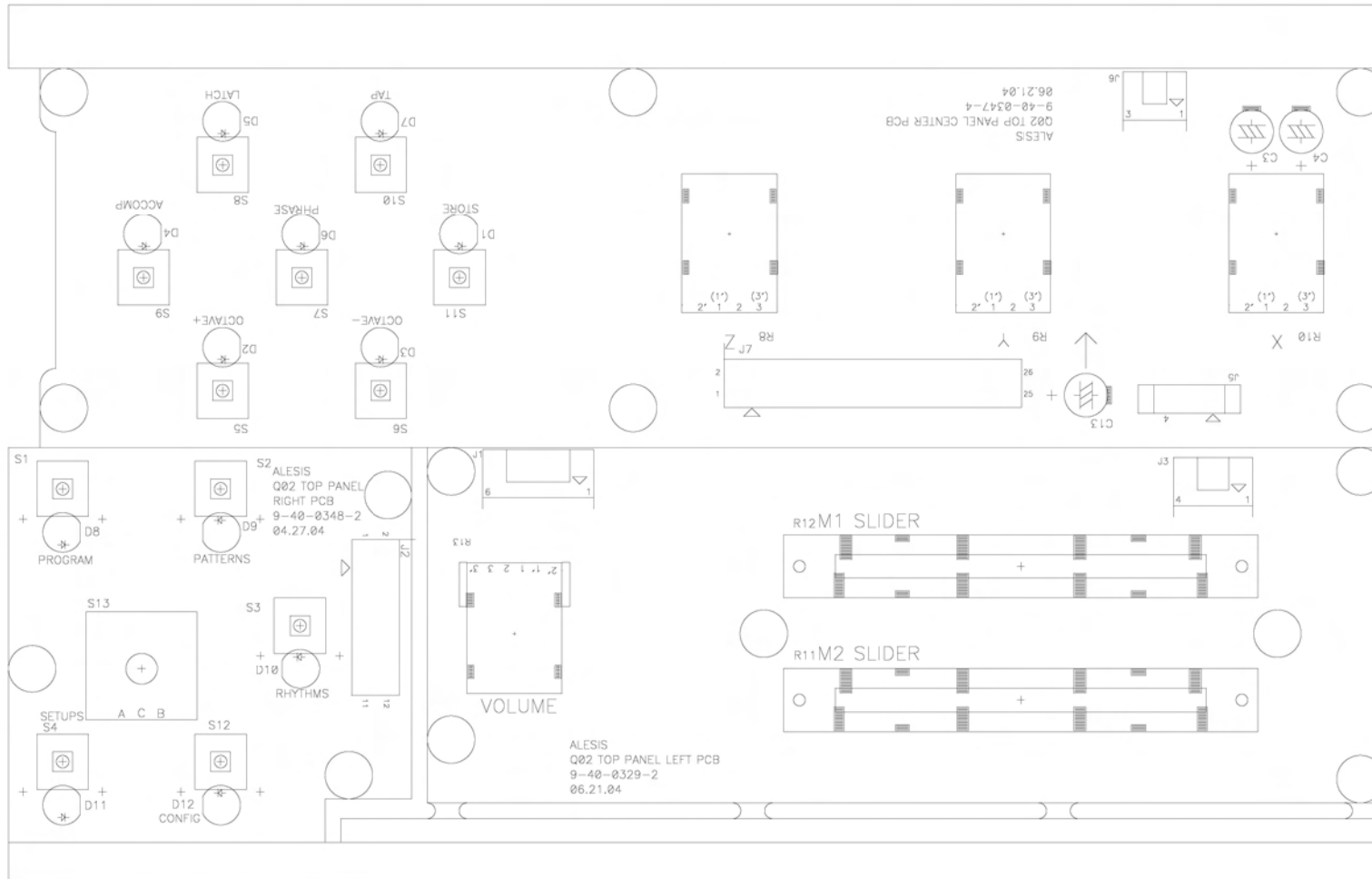

ALESIS  
 Q02 TOP PANEL CENTER PCB  
 9-40-0547-4  
 06.21.04

ALESIS  
 Q02 TOP PANEL  
 RIGHT PCB  
 9-40-0348-2  
 04.27.04

ALESIS  
 Q02 TOP PANEL LEFT PCB  
 9-40-0329-2  
 06.21.04

R12M1 SLIDER

R11M2 SLIDER

VOLUME

PROGRAM

PATTERNS

RHYTHMS

SETUPS  
A C B

CONFIG

PHRASE

STORE

OCTAVE+

OCTAVE-

LATCH

TAP

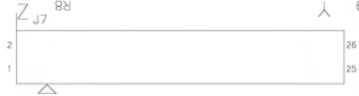
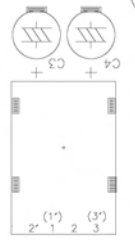
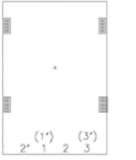
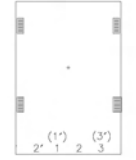
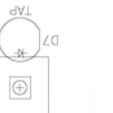
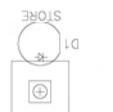
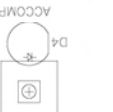
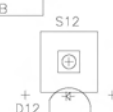
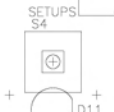
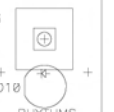
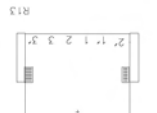



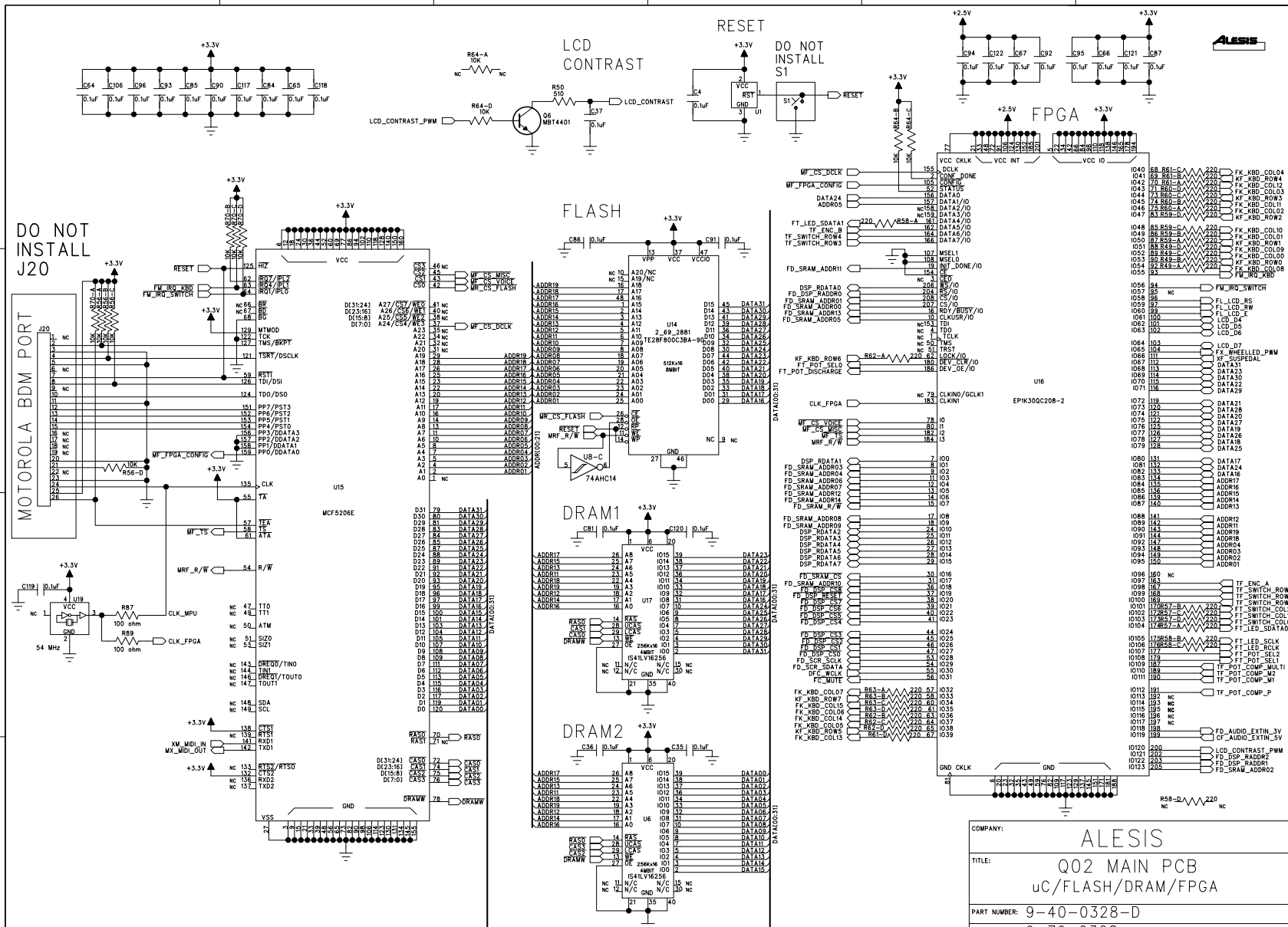

COMPANY: **ALESIS**

TITLE: **Q02 MAIN PCB**  
uC/FLASH/DRAM/FPGA

PART NUMBER: 9-40-0328-D

ASSY NUMBER: 9-79-0328

DRAWN: B.Victor      DATED: 6/16/04

RELEASED:              DATED:

FILENAME: Q02MND00a.sch      SIZE: C

SCALE:                      SHEET: 1 OF 3



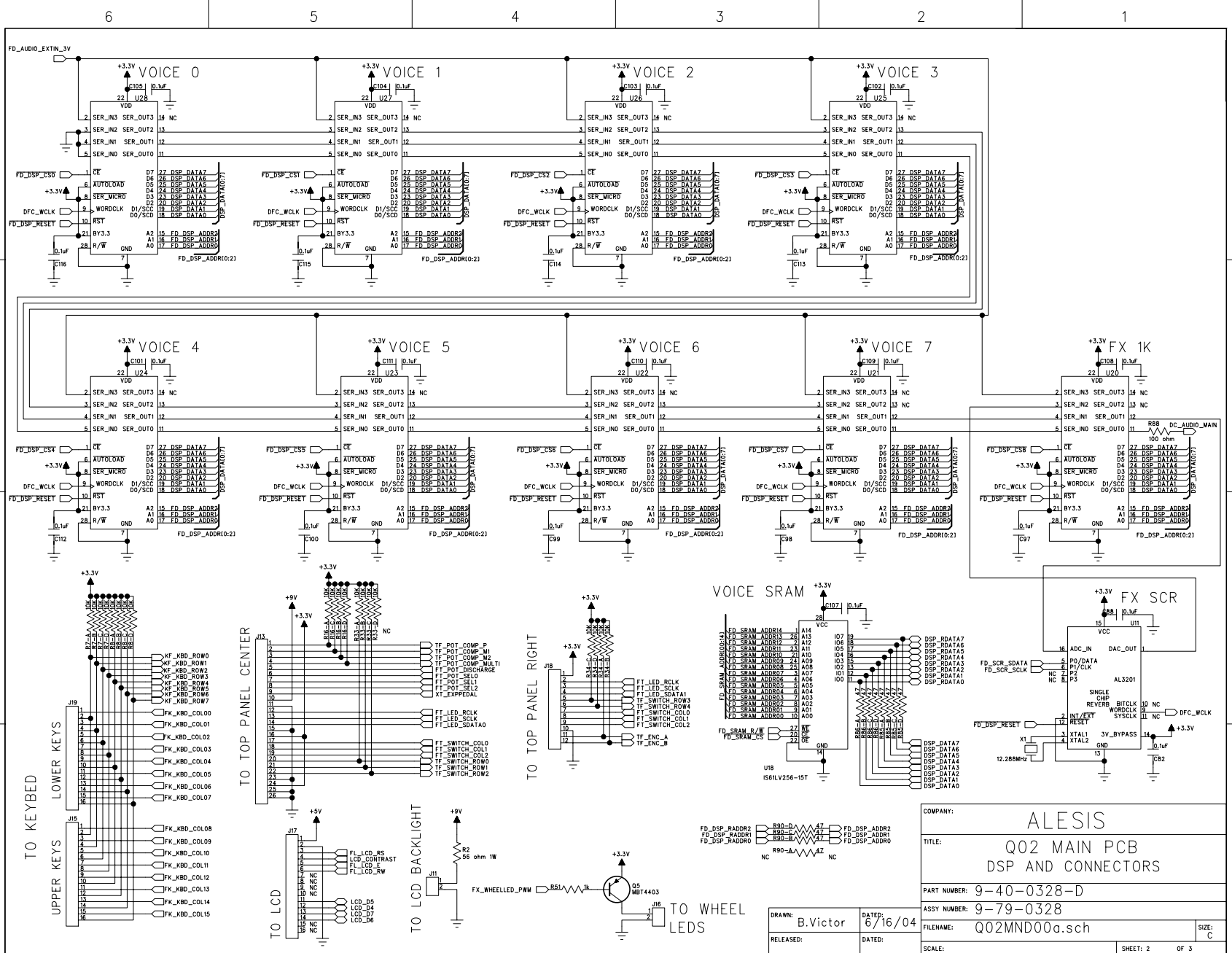

COMPANY:		ALESIS	
TITLE:		Q02 MAIN PCB DSP AND CONNECTORS	
PART NUMBER:		9-40-0328-D	
ASSY NUMBER:		9-79-0328	
FILENAME:		Q02MND00a.sch	
SCALE:	SHEET: 2	OF 3	SIZE: C

DRAWN: B.Victor  
RELEASED: DATE: 6/16/04

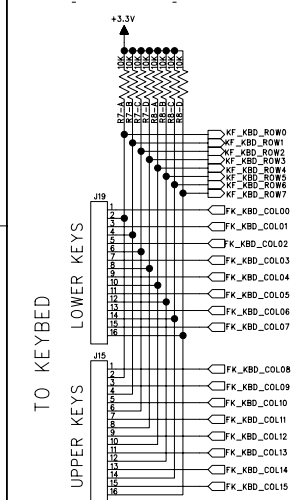
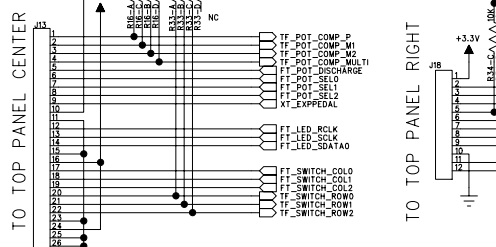
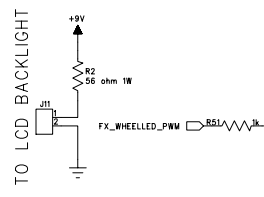
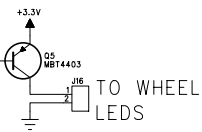

6 5 4 3 2 1

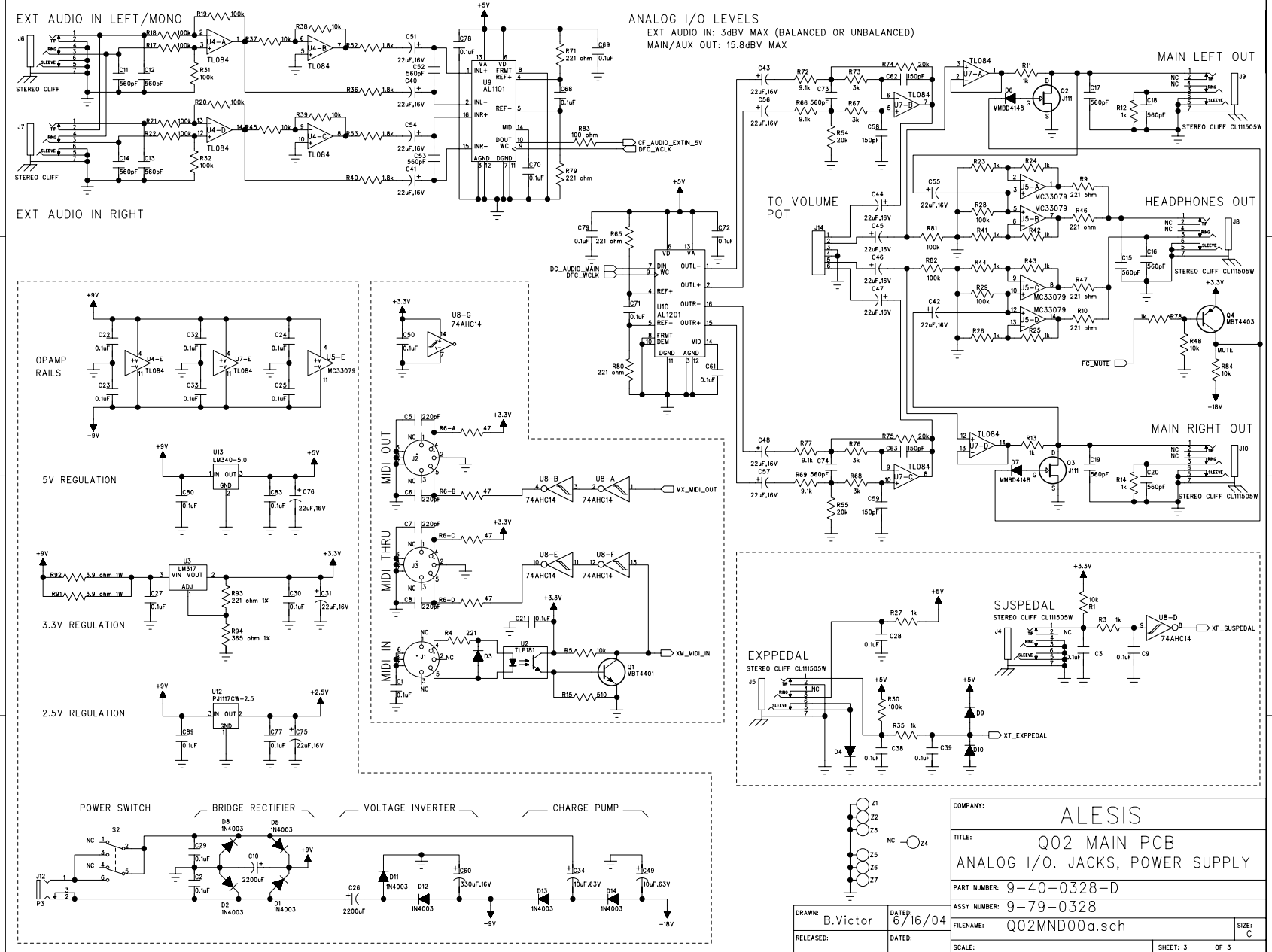

ANALOG I/O LEVELS  
EXT AUDIO IN: 3dBV MAX (BALANCED OR UNBALANCED)  
MAIN/AUX OUT: 15.8dBV MAX

COMPANY:		ALESIS	
TITLE:		Q02 MAIN PCB	
PART NUMBER:		9-40-0328-D	
ASSY NUMBER:		9-79-0328	
FILENAME:		Q02MND00a.sch	
SCALE:	SHEET: 3	OF 3	SIZE: C

DRAWN: B.Victor  
RELEASED: 6/16/04  
DATED: 6/16/04

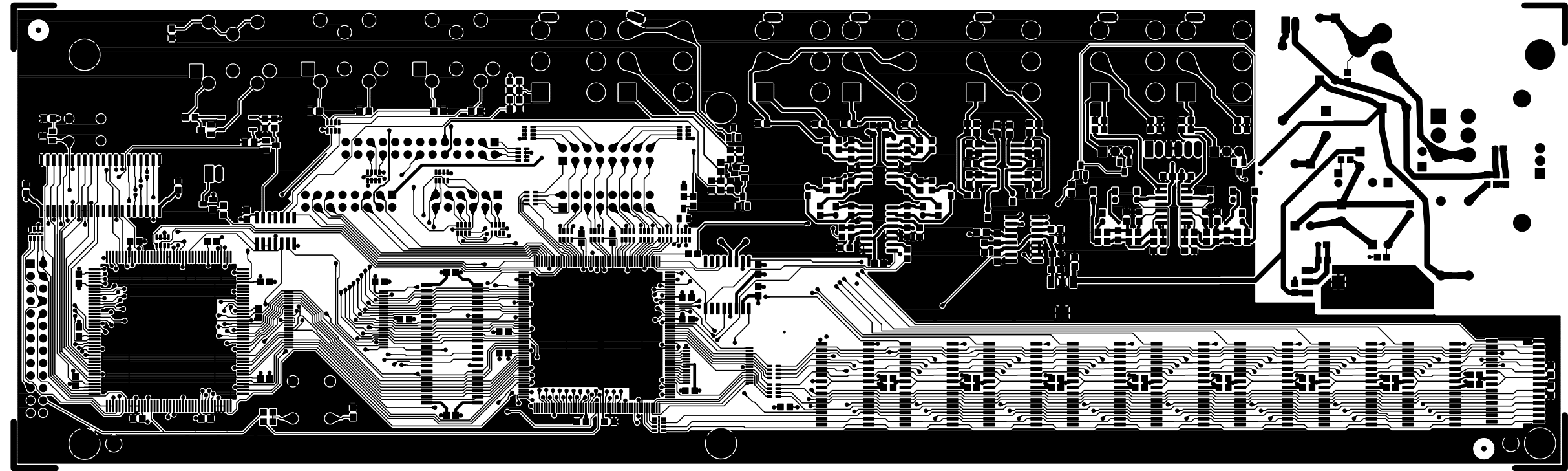

ALESIS 9-40-0328-D "TOPTRACE"

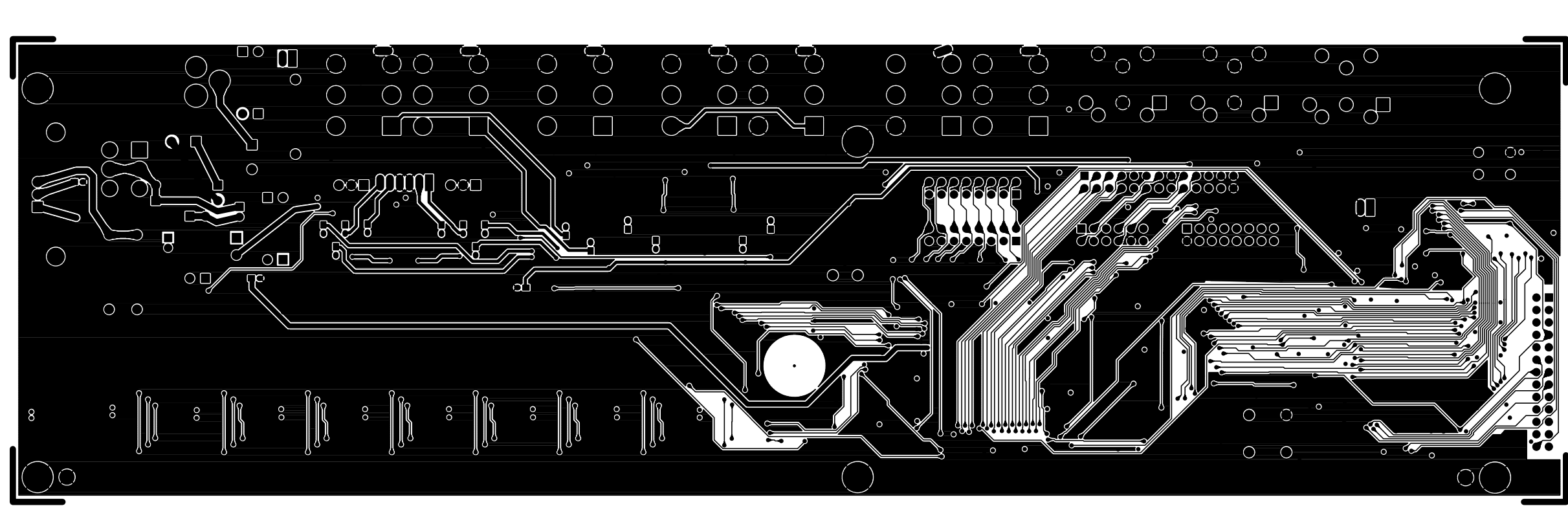

ALESIS 9-40-0328-D "BOTTRACE"

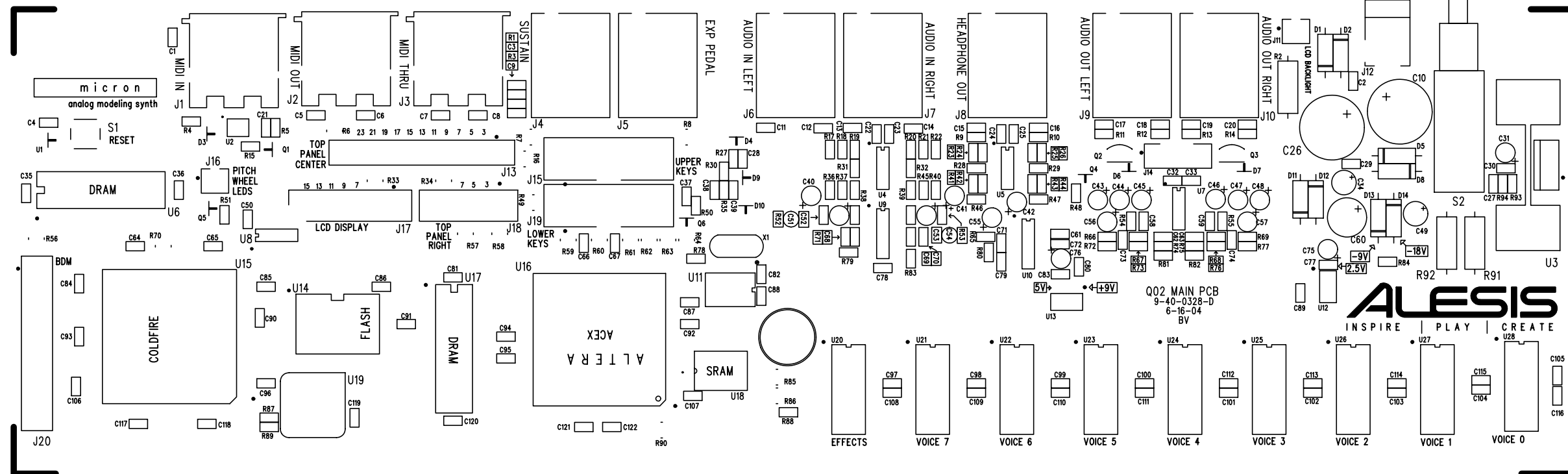

ALESIS 9-40-0328-D "TOPSILK"



6

5

4

3

2

1

E

D

C

B

A

REVISION RECORD			
LTR.	ECO NO:	APPROVED:	DATE:

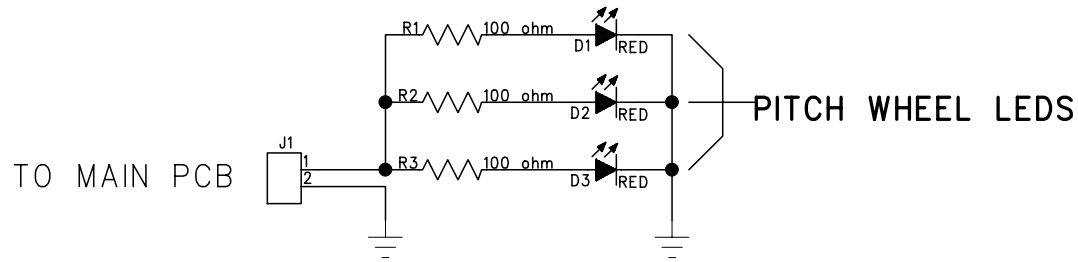

NOTES:

The manufacturer is free to choose the best type of resistor to use. (Thru hole, surface mount, quad pack, etc.)

Minimum wattage is less than 1/16 W.

COMPANY:		<b>ALESIS</b>	
TITLE:		<b>Q02 WHEEL LED PCB</b>	
PART NUMBER:		9-40-0332-1	
ASSY NUMBER:		9-79-0332	
FILENAME:		Q02WL100A.sch	SIZE: A
SCALE:		SHEET: 1	OF: 1

DRAWN:	DATED:
B.Victor	9/23/03
RELEASED:	DATED:

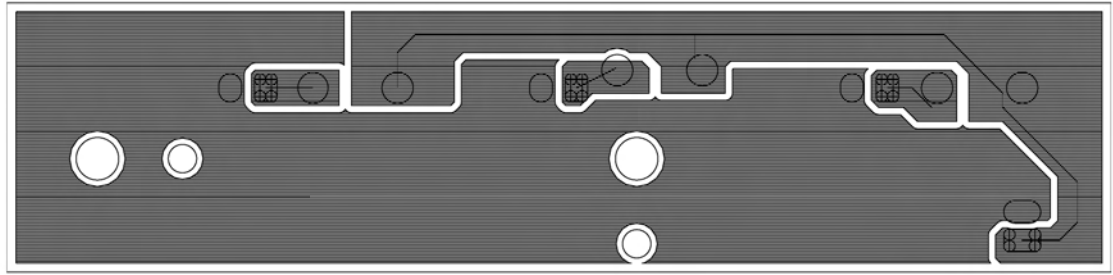

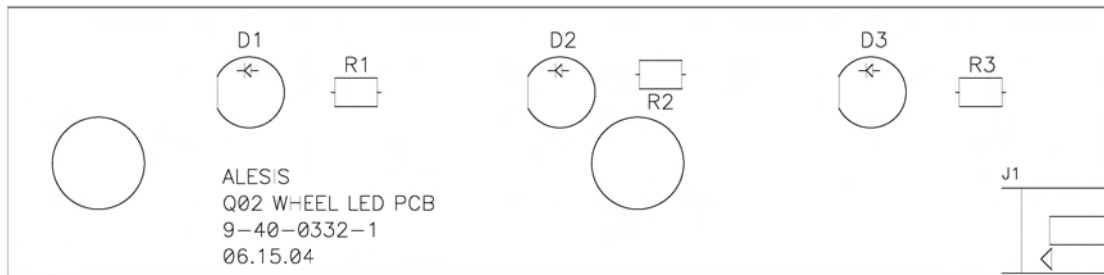



# ALESIS MICRON (Q02)

## ECN HISTORY