

ALESIS

ANDROMEDA

16-VOICE **REAL** ANALOG SYNTHESIZER

**REFERENCE
MANUAL**

For Software Version 1.40

Your shipping carton should contain the following items:

1. Andromeda A6 synthesizer
2. AC power cable
3. Sustain Pedal
4. Reference Manual

If anything is missing, please contact your dealer or Alesis immediately.

Alesis contact information:

Alesis Studio Electronics, Inc.
Los Angeles
USA

E-Mail: support@alesis.com
Website: <http://www.alesis.com>

Alesis Andromeda A6™ Reference Manual
Revision 1.0 by Dave Bertovic
Revision 1.1 by Brian R. Shim

© Copyright 2001, Alesis Studio Electronics, Inc. All rights reserved. Reproduction in whole or in part is prohibited. "A6", "QCard" and "FreeLoader" are trademarks of Alesis Studio Electronics, Inc.

CONTENTS

| | |
|---|-----------|
| Important Safety Instructions | 7 |
| Instructions to the User (FCC Notice) | 11 |
| CE Declaration of Conformity | 13 |
| Introduction | 15 |
| How to Use this Manual..... | 16 |
| Typographic Conventions..... | 17 |
| Key Terminology | 18 |
| Chapter 1: Getting Started | 21 |
| What You'll Need, Unpacking, Set Up, Power | 21 |
| Audio Connections and Pedals..... | 22 |
| MIDI Connections..... | 23 |
| Quick Start..... | 26 |
| Chapter 2: Playing the A6 | 29 |
| A Brief Tour of the Front Panel | 30 |
| How Functions are Grouped | 30 |
| Interacting with the Display | 32 |
| Selecting Programs and Mixes | 38 |
| PROGRAM Mode Parameters..... | 39 |
| MIX Mode Parameters | 39 |
| Storing Edited Programs and Mixes | 43 |
| Setting Up Splits and Layers | 47 |
| Using Global Mode..... | 49 |
| GLOBAL Mode Parameters | 49 |
| Master Controls..... | 52 |
| Volume..... | 52 |
| Tune..... | 52 |
| The Keyboard and Keyboard Modes | 54 |
| Performance Features (KBD MODE, UNISON X, DETUNE) | 55 |
| Portamento..... | 59 |
| The Performance Wheels and Ribbon Controller..... | 65 |
| Programming the Wheels and Ribbon..... | 66 |
| Pedals and Footswitches | 68 |
| The CLOCK Section..... | 69 |
| Clock Parameters | 70 |
| Sequencer | 71 |
| Arpeggiator..... | 79 |
| Chapter 3: Basics of Analog Synthesis | 81 |
| An Overview of Synthesis..... | 81 |
| Analog and Digital Technologies | 81 |
| A Little History | 81 |
| A Little Theory | 82 |
| Waveforms | 82 |
| Fundamentals and Harmonics | 83 |
| Sound Dynamics | 84 |
| LFOs | 87 |
| Components of an Analog Synthesizer | 88 |

| | |
|--|------------|
| Chapter 4: Overview of the Andromeda A6 | 93 |
| A Few Basic Concepts | 93 |
| A6 Function List | 95 |
| A6 Functions At-a-Glance | 97 |
| MIDI Overview | 102 |
| | |
| Chapter 5: Oscillators and Filters | 103 |
| Oscillators..... | 103 |
| Oscillator Parameter Descriptions | 104 |
| VCO Modulation | 107 |
| Filters..... | 116 |
| What Filters Do | 116 |
| How Filters Are Designed..... | 117 |
| How Filters Work | 122 |
| Filter Parameter Descriptions | 127 |
| | |
| Chapter 6: Modulation and Envelopes | 131 |
| Modulation..... | 131 |
| Background | 131 |
| Modulation Principles | 131 |
| Hardware and Software Modulation, Default Mod Paths | 133 |
| Envelopes | 134 |
| Envelope Properties | 134 |
| Envelope Parameter Descriptions | 135 |
| TIME Page Parameters..... | 137 |
| SHAPE: Selecting the Stage Slope | 139 |
| LEVEL Page Parameters | 141 |
| TRIG Page Parameters | 142 |
| Envelope Modes (Norm 1 & 2, Freerun, Susrel) | 144 |
| Envelope Modulation Triggering (MODTRG)..... | 153 |
| How Modulation Triggering Works | 155 |
| DYN Page Parameters | 158 |
| LOOP Page Parameters | 160 |
| MOD Pages | 164 |
| Envelope Examples | 165 |
| | |
| Chapter 7: LFOs, Sample & Hold and Process..... | 171 |
| Low Frequency Oscillators | 171 |
| LFO Parameter Descriptions | 171 |
| WAVE Page | 172 |
| TRIG Page | 175 |
| SYNC Page..... | 176 |
| MOD Page..... | 176 |
| Using LFOs as a Trigger Source..... | 176 |
| Sample and Hold | 177 |
| PROCESS Module..... | 179 |
| Tracking Generator (TGEN) | 179 |
| Track Gen Level and Track Gen Step..... | 179 |
| Tracking Generator Parameter Descriptions..... | 180 |
| | |
| Chapter 8: The A6 Mixing System | 183 |
| Pre Filter Mix/Post Filter Mix | 183 |
| Pre Filter Mix Overview | 183 |
| Pre Filter Mix Operation..... | 184 |
| OSC and SUB OSC Controls | 184 |
| RING MOD Control | 184 |
| NOISE/EXTERNAL Control..... | 185 |
| Signal Routing through the Filters | 187 |

| | |
|--|------------|
| Post Filter Mix Overview | 189 |
| Post Filter Mix Operation | 189 |
| Voice Mix..... | 190 |
| MAIN and AUX outputs | 190 |
| Setting Levels in Mix Mode | 190 |
| Individual VOICE OUTPUT | 190 |
| Chapter 9: Custom Modulations | 191 |
| MOD Functions Overview | 191 |
| Avoid duplication with hard-wired mods..... | 191 |
| Performance control of mods | 192 |
| Using the Modulation Matrix..... | 192 |
| A Few Ground Rules..... | 197 |
| The Control Routes Section..... | 198 |
| To change modulation amounts using the CROUTES page: | 198 |
| To change the source of a Control Route: | 199 |
| About Signal Flow in a MOD Path..... | 200 |
| About Modulation Sources | 201 |
| Chapter 10: Using Effects | 203 |
| Introduction | 203 |
| Signal Flow..... | 203 |
| Basic Controls | 203 |
| Analog Distortion | 204 |
| Editing Digital Effects | 205 |
| To select a Digital Effects Configuration Type:..... | 205 |
| Editing Effect Parameters..... | 206 |
| Choosing a Parameter Page | 206 |
| Changing an Individual Parameter..... | 206 |
| MOD: Modulating Effects Send/Output | 207 |
| Tutorial: How to Edit a Reverb | 208 |
| Set the Type and Audio Levels | 208 |
| Set the Reverb's Decay and Tone..... | 208 |
| Set the Reverb Predelay | 209 |
| Change the Tone of the Reverb Decay..... | 209 |
| Adjust the Mix | 210 |
| Digital Effects Architecture..... | 211 |
| The Signal Flow Through the Effects Section | 211 |
| Single..... | 211 |
| Dual Effects: Parallel | 212 |
| Dual Effects: Mono | 213 |
| Multi Chain | 214 |
| Configurations & Parameter Descriptions..... | 215 |
| Reverbs | 215 |
| Delays..... | 220 |
| Pitch Effects..... | 222 |
| Table of Digital Effects Parameters | 227 |
| Chapter 11: Mix Mode | 243 |
| What is a Mix? | 243 |
| Mix Channels vs. MIDI Channels..... | 243 |
| Common Mix Settings for MIDI Sequencers..... | 244 |
| To make a custom multitimbral Mix:..... | 244 |
| MIDI Program Change Messages..... | 245 |
| Editing Programs from Mix Mode | 245 |
| Mix SOLO..... | 245 |

Contents

| | |
|--|------------|
| To copy a Mix Channel from another Mix:..... | 245 |
| Effects in Mix Mode..... | 246 |
| To set effect send levels for different Mix Channels: | 246 |
| To copy an effect from another Program or Mix: | 246 |
| Chapter 12: MIDI Functions | 247 |
| MIDI Basics | 247 |
| MIDI Hardware..... | 247 |
| MIDI Messages..... | 248 |
| To send an individual Program or Mix out as a MIDI System Exclusive dump:..... | 253 |
| To send an entire Program or Mix Bank out as a MIDI System Exclusive dump:..... | 254 |
| About receiving SysEx dumps: | 254 |
| MIDI and the A6 Andromeda | 255 |
| A6 Channel Messages: Multitimbral Sequencing..... | 255 |
| Setting MIDI Parameters in Global Mode..... | 256 |
| Appendix A: Glossary | 259 |
| Appendix B: Table of Mod Sources | 261 |
| Appendix C: Troubleshooting | 265 |
| The Auto Tune Display | 265 |
| How to Use the Tune Display | 266 |
| Upgrading the Operating System..... | 268 |
| Troubleshooting Chart..... | 270 |
| Cleaning and Maintenance | 272 |
| Appendix D: Specifications | 273 |
| MIDI Implementation Chart..... | 273 |
| Specifications | 274 |
| Appendix E: Warranty | 275 |
| Index | 277 |

IMPORTANT SAFETY INSTRUCTIONS

SAFETY SYMBOLS USED IN THIS PRODUCT



This symbol alerts the user that there are important operating and maintenance instructions in the literature accompanying this unit.



This symbol warns the user of uninsulated voltage within the unit that can cause dangerous electric shocks.

PLEASE FOLLOW THESE PRECAUTIONS WHEN USING THIS PRODUCT:



1. *Read these instructions.*

2. Keep these instructions.
3. Heed all warnings.
4. Follow all instructions.
5. Do not use this apparatus near water.
6. Clean only with a damp cloth. Do not spray any liquid cleaner onto the faceplate, as this may damage the front panel controls or cause a dangerous condition.
7. Install in accordance with the manufacturer's instructions.
8. Do not install near any heat sources such as radiators, heat registers, stoves, or other apparatus (including amplifiers) that produce heat.
9. Do not defeat the safety purpose of the polarized plug on the AC power adapter. A polarized plug has two blades with one wider than the other. The wide blade is provided for your safety. When the provided plug does not fit into your outlet, consult an electrician for replacement of the obsolete outlet.
10. Protect the power cord from being walked on or pinched, particularly at plugs, convenience receptacles, and the point where they exit from the apparatus.
11. Use only attachments or accessories specified by the manufacturer.



Important Safety Instructions



12. Use only with a cart, stand, bracket, or table designed for use with professional audio or music equipment. In any installation, make sure that injury or damage will not result from cables pulling on the apparatus and its mounting. If a cart is used, use caution when moving the cart/apparatus combination to avoid injury from tip-over.

13. Unplug this apparatus during lightning storms or when unused for long periods of time.



14. Refer all servicing to qualified service personnel. Servicing is required when the apparatus has been damaged in any way, such as when the power-supply cord or plug is damaged, liquid has been spilled or objects have fallen into the apparatus, the apparatus has been exposed to rain or moisture, does not operate normally, or has been dropped.

15. This unit produces heat when operated normally. Operate in a well-ventilated area.

16. This product, in combination with an amplifier and headphones or speakers, may be capable of producing sound levels that could cause permanent hearing loss. Do not operate for a long period of time at a high volume level or at a level that is uncomfortable. If you experience any hearing loss or ringing in the ears, you should consult an audiologist.

17. **WARNING:** To reduce the risk of fire or electric shock, do not expose this apparatus to rain or moisture.

INSTRUCTIONS DE SÉCURITÉ IMPORTANTES (FRENCH)

SYMBOLES UTILISÉS DANS CE PRODUIT



Ce symbole alerte l'utilisateur qu'il existe des instructions de fonctionnement et de maintenance dans la documentation jointe avec ce produit.



Ce symbole avertit l'utilisateur de la présence d'une tension non isolée à l'intérieur de l'appareil pouvant engendrer des chocs électriques.

VEUILLEZ SUIVRE CES PRÉCAUTIONS LORS DE L'UTILISATION DE L'APPAREIL:

1. Lisez ces instructions.
2. Gardez ces instructions.
3. Tenez compte de tous les avertissements.
4. Suivez toutes les instructions.
5. N'utilisez pas cet appareil à proximité de l'eau.
6. Ne nettoyez qu'avec un chiffon humide. Ne pas vaporiser de liquide nettoyant sur l'appareil, cela pourrait abîmer les contrôles de la face avant ou engendrer des conditions dangereuses.
7. Installez selon les recommandations du constructeur.
8. Ne pas installer à proximité de sources de chaleur comme radiateurs, cuisinière ou autre appareils (don't les amplificateurs) produisant de la chaleur.
9. Ne pas enlever la prise de terre du cordon secteur. Une prise murale avec terre deux broches et une troisième reliée à la terre. Cette dernière est présente pour votre sécurité. Si le cordon secteur ne rentre pas dans la prise de courant, demandez à un électricien qualifié de remplacer la prise.
10. Evitez de marcher sur le cordon secteur ou de le pincer, en particulier au niveau de la prise, et aux endroits où il sort de l'appareil.
11. N'utilisez que des accessoires spécifiés par le constructeur.
12. N'utilisez qu'avec un stand, ou table conçus pour l'utilisation d'audio professionnel ou instruments de musique. Dans toute installation, veillez de ne rien endommager à cause de câbles qui tirent sur des appareils et leur support.
13. Débranchez l'appareil lors d'un orage ou lorsqu'il n'est pas utilisé pendant longtemps.

Important Safety Instructions

14. Faites réparer par un personnel qualifié. Une réparation est nécessaire lorsque l'appareil a été endommagé de quelque sorte que ce soit, par exemple lorsque le cordon secteur ou la prise sont endommagés, si du liquide a coulé ou des objets se sont introduits dans l'appareil, si celui-ci a été exposé à la pluie ou à l'humidité, ne fonctionne pas normalement ou est tombé.
15. Cet appareil produit de la chaleur en fonctionnement normal.
16. Ce produit, utilisé avec un amplificateur et un casque ou des enceintes, est capable de produire des niveaux sonores pouvant engendrer une perte permanente de l'ouïe. Ne l'utilisez pas pendant longtemps à un niveau sonore élevé ou à un niveau non confortable. Si vous remarquez une perte de l'ouïe ou un bourdonnement dans les oreilles, consultez un spécialiste.

BEIM BENUTZEN DIESES PRODUKTES BEACHTEN SIE BITTE DIE FOLGENDEN SICHERHEITSHINWEISE: (GERMAN)

1. Lesen Sie die Hinweise.
2. Halten Sie sich an die Anleitung.
3. Beachten Sie alle Warnungen.
4. Beachten Sie alle Hinweise.
5. Bringen Sie das Gerät nie mit Wasser in Berührung.
6. Verwenden Sie zur Reinigung nur ein weiches Tuch. Sprühen Sie keine flüssiger Reiniger auf die Oberfläche, dies könnte zur Beschädigung der Vorderseite führen und auch weitere Schäden verursachen.
7. Halten Sie sich beim Aufbau des Gerätes an die Angaben des Herstellers.
8. Stellen Sie das Gerät nicht in der Nähe von Heizkörpern, Heizungsklappen oder anderen Wärmequellen (einschließlich Verstärkern) auf.
9. Verlegen Sie das Netzkabel des Gerätes niemals so, daß man darüber stolpern kann oder daß es gequetscht wird.
10. Benutzen Sie nur das vom Hersteller empfohlene Zubehör.
11. Verwenden Sie ausschließlich Wagen, Ständer, oder Tische, die speziell für professionelle Audio- und Musikinstrumente geeignet sind. Achten Sie immer darauf, daß die jeweiligen Geräte sicher installiert sind, um Schäden und Verletzungen zu vermeiden. Wenn Sie einen Rollwagen benutzen, achten Sie darauf, das dieser nicht umkippt, um Verletzungen auszuschließen.
12. Ziehen Sie während eines Gewitters oder wenn Sie das Gerät über einen längeren Zeitraum nicht benutzen den Netzstecker aus der Steckdose.
13. Die Wartung sollte nur durch qualifiziertes Fachpersonal erfolgen. Die Wartung wird notwendig, wenn das Gerät beschädigt wurde oder aber das Stromkabel oder der Stecker, Gegenstände oder Flüssigkeit in das Gerät gelangt sind, das Gerät dem Regen oder Feuchtigkeit ausgesetzt war und deshalb nicht mehr normal arbeitet oder heruntergefallen ist.
14. Bei normalem Betrieb des Gerätes kommt es zu Wärmeentwicklungen.
15. Dieses Produkt kann in Verbindung mit einem Verstärker und Kopfhörern oder Lautsprechern Lautstärkepegel erzeugen, die anhaltende Gehörschäden verursachen. Betreiben Sie es nicht über längere Zeit mit hoher Lautstärke oder einem Pegel, der Ihnen unangenehm is. Wenn Sie ein Nachlassen des Gehörs oder ein Klingeln in den Ohren feststellen, sollten Sie einen Ohrenarzt aufsuchen.

INSTRUCTIONS TO THE USER

This equipment has been tested and found to comply with the limits for a class B digital device, pursuant to Part 15 of the FCC Rules. These limits are designed to provide reasonable protection against harmful interference in a residential installation. This equipment generates, uses, and can radiate radio frequency energy and, if not installed and used in accordance with the instructions, may cause harmful interference to radio communications. However, there is no guarantee that interference will not occur in a particular installation. If this equipment does cause harmful interference to radio or television reception, which can be determined by turning the equipment off and on, the user is encouraged to try and correct the interference by one or more of the following measures:

- Reorient or relocate the receiving antenna.
- Increase the separation between the equipment and receiver.
- Connect the equipment into an outlet on a circuit different from that to which the receiver is connected.
- Consult the dealer or an experienced radio/TV technician for help.

This equipment has been verified to comply with the limits for a class B computing device, pursuant to FCC Rules. In order to maintain compliance with FCC regulations, shielded cables must be used with this equipment. Operation with non-approved equipment or unshielded cables is likely to result in interference to radio and TV reception. The user is cautioned that changes and modifications made to the equipment without the approval of manufacturer could void the user's authority to operate this equipment.

CE DECLARATION OF CONFORMITY

Please see the Alesis website, www.alesis.com, for the CE Declaration of Conformity

INTRODUCTION

There was a time when most of us thought that analog synthesis was dead. Yeah, there were a few new analog instruments – and rather decent ones, at that – that have come and gone over the past few years. They were glimmers of hope that the robust, full and rich sounds of the analogs could peacefully co-exist with the digitals. I was excited that a handful of manufacturers were still “carrying the ball” and believed that there will always be a place in the music world for a great analog synth. But for some reason, these instruments – as good as they are – seem to be a little lacking in many respects.

Then I was introduced to the Andromeda A6. Simply stated, this box has more features and music power per square inch than any other synthesizer I’ve owned. And I’ve owned a bunch of them, starting with an obscure little monophonic instrument called the MiniMoog® in 1973. To me, the A6 represents the next significant step in the development of musical instruments that celebrate this technology.

The Andromeda A6 starts out with 16 of the most elaborate synthesizer voices to date, and these voices sound absolutely wonderful. The attention to detail applied as Alesis Engineering researched the great analog synths of the past has paid off in producing an instrument that has the world-class analog sound, complete with every nuance. There’s nothing “virtual” about the A6: it is a real analog synthesizer.

This synthesizer has more modulation and control functionality than most players can fully use in a lifetime. It has an studio-quality effects system, an elaborate MIDI system and one of the most logical and useful displays on the market. Add to that an Arpeggiator, a classic 16-event Sequencer, a Ribbon controller and CV inputs, and you have an analog powerhouse with all of the tools — and all of the toys.

Last, but certainly not least, the A6 is gorgeous. And its striking layout and front panel artwork is every bit as functional as it is beautiful.

We’ve just touched on the some of the highlights of this product; there’s much more to be explored. After you’ve read through this Reference, and experienced the sound and feel of the A6, I’m confident that you will be every bit as excited about it as I am.

There will always be a place in the music world for a great analog synth.

Dave Bertovic
Winter 2001

HOW TO USE THIS MANUAL

STRUCTURE

This manual was designed to take you through the A6 in a logical order of topics. This way, anyone who is new to this type of instrument can read through the book from front to back and get the most basic information first. The manual progressively deals with more complex topics as you read through to the end. Experienced users can simply use this manual as a reference resource, browsing through the topics as needed. An Index is provided at the end of the manual for quick referrals to specific subjects or problems. The Appendices provide technical information about the A6.

The Chapters can be grouped into five categories of information:

Overview – Chapters 1 and 2

Chapter 1 is your basic introduction to the A6, from getting it out of the box, setting it up and plugging it in to making simple audio and MIDI connections, and hooking up pedals and footswitches.

Once you get everything connected, Chapter 2 takes you on a detailed tour of the A6. This Chapter runs you through the most commonly used performance features of the unit, including a discussion of how the display works and how to select sounds. We'll also take a good look at Master Volume and Tune, the keyboard and its modes, Portamento, the Sequencer and Arpeggiator, the two performance Wheels and the Ribbon Controller.

Synthesis and the A6 – Chapters 3 and 4

This section of the manual starts out with Chapter 3 giving you a broad background of analog synthesis, including some history and acoustic theory. All of this is then applied to a generic analog synthesizer to illustrate the electronic counterparts of a sound's components.

If you are new to analog synthesis, we strongly recommend that you read this Chapter in its entirety. What you will learn here will help the rest of the manual make sense.

Where Chapter 3 provides you with concepts, Chapter 4 brings it all home to the A6. Here, you'll learn how the A6's sounds are organized, and how the front and back panels are laid out. A complete list of the A6's functions are presented along with concise descriptions.

Program Functions – Chapters 5, 6, 7, 8, and 9

These five Chapters take you through every function that makes up a Program. Here's where the theory we covered in Chapter 3 meets reality: what the knobs and switches do to affect each aspect of the sound.

Sound Applications – Chapters 10, 11 and 12

Chapter 10 covers all the bases when it comes to using the Andromeda's powerful internal effects. Chapter 11 deals with Mix mode: the A6's memory functions for combining two or more Programs. Mix mode is where you create splits and layers, **multiple** splits and layers and other multitimbral configurations. We'll also explore incorporating external Programs with the A6's internal sounds.

Chapter 12 takes a good, long look at MIDI: an introductory tutorial on MIDI functions followed by MIDI operations specific to the A6.

Technical – The Appendices

The appendices at the end of the A6 Reference Manual provide concise information about the instrument from a technical perspective:

Appendix A is a complete reference that documents every function in the unit.

Appendix B is glossary of common terms we use throughout the manual.

Appendix C provides troubleshooting assistance and covers the majority of common problems you might incur while using the A6.

Appendix D provides a list of the A6's technical and design specifications including the instrument's MIDI Implementation Chart.

Appendix E covers all warranty, servicing and maintenance issues.

The Index is a comprehensive cross-reference to all of the topics and terminology in the manual.

TYPOGRAPHIC CONVENTIONS

Knob, button and back panel jack labels are printed in **SMALL BOLD CAPITALS**.

Words or phrases that appear in the display are printed using type that resembles the `DISPLAY` characters.

A new or important term is in *italics* followed by its definition or contextual meaning.

Paragraphs in italics provide additional information on a topic that might be helpful in understanding certain important concepts.

Tip: A hint or special example called a *Tip* is set off from the main text by a box with a light-gray fill.

Important instructions or emphasis on a word or phrase are **printed in boldface type**.

KEY TERMINOLOGY

While we define terms throughout this manual, and also provide a Glossary at the end, we'd like to list a few terms now that will help you get a head start on some of the technical expressions used in this document:

Voice

A synthesizer *voice* is the most basic component of a synthesizer that produces sound. A voice is all of the hardware and software that is necessary to produce one note of sound.

The A6 has 16 voices: 16 independent "sound-producing components" that play when a key or keys are played on its keyboard, or when MIDI Notes are received. This also means that 16 voices is the limit: if you play more than 16 keys at a time (or the A6 receives more than 16 MIDI Notes), only 16 will play.

Program and Mix

Where a voice is the instrument's sound-producing component, a Program is all the **settings** that cause the voices to produce a **particular** sound. This is where many of the front panel controls come in. They are used to create the individual sounds of the A6 and their values (settings) are stored as a Program.

A Mix is two or more Programs that can be played at the same time. Mix mode is where you make settings for splits and layers plus numerous combinations of Programs, and keyboard/MIDI control.

RAM and ROM

Related to Programs and Mixes, these two terms refer to the physical circuit chips inside the A6 where data is stored. RAM stands for Random Access Memory and is a type of memory that you can change. This manual refers to RAM as **user** memory.

In addition to Programs and Mixes, Global settings are also stored in RAM (see the definition of *Global* mode later in this topic).

ROM stands for Read Only Memory and is a type of memory that is, for the most part, permanent. The A6 uses a type of ROM called *Flash ROM* which can be modified but only under special circumstances. So, for all intents and purposes, consider ROM to be read-only. This manual refers to ROM as **preset** memory.

Parameter

Virtually all of the main functions of the A6 are comprised of smaller elements or parts. These elements are all related in some way to the overall operation of the function they constitute. Each of these elements or parts is referred to as a *parameter*.

Using an Envelope as an example, it is comprised of no less than 47 parameters: six adjustments for time, five adjustments for level, eight trigger settings, six dynamics settings, eight loop parameters, plus settings for slope (with nine options), 12 modulation parameters and clock-synchronization settings.

Page

The display will group a function's parameters together on the screen called a display *page*. Some A6 functions have more than one page because they have more parameters than can be displayed in the available screen area. This is called a *multi-page* display and each page's title is printed on a page *tab* which resembles a tab in a notebook.

Editing

When you make a change to a parameter in a Program or Mix, or to a Global function – by adjusting its numeric value, turning it on or off and so forth – this is called editing.

Offset

Many of the Andromeda A6's parameters have an additional adjustment called *offset*. This is simply an adjustment of the parameter by a fixed amount

Default

When the A6 is shipped from the factory, each of its parameters has a pre-assigned value called a *default*. This is so that when a parameter is selected, it displays **some** setting – on or off status, positive or negative status, a number or another appropriate entry – that is either a neutral setting, or one that's a good starting point for editing.

Amplitude

The most common use of this word is using it to describe loudness or volume. But strictly speaking, amplitude refers to the level of a signal, its "intensity" (or lack of it) or the "signal strength". And this includes **any** signal: the sound coming from the oscillators, vibrato from an LFO, an envelope and so forth.

So care must be taken not to associate amplitude with volume exclusively; it can be (and most often is) used to **generically** describe a signal's level whether it's volume or not. When we cover envelopes in the next chapter, for example, amplitude control is one of an envelope's main characteristics, but it doesn't always mean volume. We'll simply use the term amplitude when referring to any kind of level.

Frequency

The most common use of this word is to describe musical pitch or notes. Although this is accurate, there are other things that have frequency even though you might not be able to hear them directly. Frequency is defined as rate or speed, usually expressed in "cycles-per-second" which indicates how many times a wave or pattern is repeated in one second. Cycles-per-second is most often referred to as "Hertz" – abbreviated "Hz" – named after the German physicist who established this unit of measurement, Heinrich Hertz. Many of our examples will involve frequencies in the thousands of cycles per second, referred to as "kilo-Hertz" and abbreviated "kHz".

We'll use the term frequency to refer to the rate of repetition of **any** component of the A6: the pitch of the **VCOs**, the speed of the **LFOs**, the harmonic characteristics of the **FILTERs** and the **CLOCK** rate, among others.

Note On and Note Off

The A6 can be played from four sources. The two primary ones are its own built-in keyboard, or a MIDI device such as another MIDI keyboard. It also can be played by a sequencer (including software sequencers running on a computer), or a drum machine – anything capable of sending MIDI Note On commands and a MIDI Note Off commands. In addition, the A6 can be "played" by its own Sequencer and Arpeggiator.

To simplify our discussions in the manual, we'll use the term *Note On* to refer to a key being pressed on the A6's keyboard, a MIDI Note On message being received by the A6, or notes being played from the A6's Arpeggiator and Sequencer, since they all essentially accomplish the same thing.

We'll use the term *Note Off* when referring to a pressed key being let go on the A6's keyboard, a received MIDI Note Off message or the end of the Gate Time from the Sequencer and Arpeggiator.

Trigger and Gate

The concept of triggers and gates is often a confusing one for many synthesizer users. They are similar in that they both instruct a modulation source to begin, but that's where the similarity ends.

A *trigger* is best described as a "go" signal that is routed from a source (such as the keyboard) to a modulation function. A trigger has no significant duration as it is

simply an electronic pulse. Translating our definition of trigger to MIDI, a trigger is the equivalent of a Note On command.

By contrast, a *gate* not only performs a “go” instruction but also carries with it a duration characteristic. Using the keyboard as in the above example, a gate signal is active **for the time that a key is held down**; a trigger is generated only at the instant the key is first played. Translating our definition of gate to MIDI, the duration of a gate is **the time that elapses** between the Note On and the Note Off commands.

LED

This acronym stands for Light Emitting Diode, a technical name for a simple feature. It refers to the small panel lights on the A6’s front panel. When an LED next to a knob or button is on, this indicates that the function is active.

Global

The term *global*, used often in this manual, refers to any function that affects the A6 no matter what play mode it’s in: global functions affect all Programs and Mixes. You can think of global functions as “master” functions. Master Tune is a perfect example of this – it tunes the whole instrument. Other global functions, described in detail later in the manual, include Master Volume, Pitch and Mod Wheel assignments, the Clock’s tempo and certain MIDI functions. While not programmable in the sense of being stored with Programs and Mixes, global settings are kept in a section of RAM dedicated to global functions and are retained when the A6 is turned off.

Linear, Exponential and Logarithmic

These are mathematical terms that are used in A6 to describe the way certain functions perform, most notably Envelope stages and Portamento. When a function is said to have a “linear response”, we mean that it produces an even rate of change that, when depicted by a graph, resembles a **straight line** (hence the term “linear”).

Functions that have exponential and logarithmic responses produce rates of change that accelerate (speed up) or decelerate (slow down) rather than stay even. Instead of a straight line which represents simple ratios, expo and log functions are a little more complex and are graphed by **curves**.

CHAPTER 1

GETTING STARTED

WHAT YOU'LL NEED

The A6's basic requirements include:

1. an AC electrical outlet
2. a stand or table to put it on
3. audio cables and a sound system or amplifier, or a pair of headphones

USING THE A6 WITH OTHER INSTRUMENTS

If you plan to use the A6 with other MIDI devices, you'll need standard MIDI cables that connect your A6 to other MIDI devices in your system. See the topic **Hook It Up** below for more information. It would also help if you have basic working knowledge of MIDI. If you're new to MIDI, read our MIDI tutorial in Chapter 10.

UNPACK IT

The A6 is packaged in a cardboard box with molded styrofoam inserts. After you remove your A6, its AC power cord, the Warranty card and this manual, we suggest you keep all packing materials in a safe place. You'll need the box and styrofoam in case the unit needs to be transported or shipped.

SET IT UP

You can place the A6 just about anywhere that's convenient. Before placing the A6 on a stand or table, be certain that is capable of securely holding an object that weighs 40 lbs. (18.15kg). You should also consider any pounding that you might be giving it. If the stand collapses under the A6's weight (or your playing), the unit could suffer permanent damage and you could be injured. Take the time right now to make sure that your stand is adequate.

HOOK IT UP

POWER

Use the AC power cord (or equivalent) that is included with the A6. Make sure that the unit is turned off before you plug the power cord into the rear panel receptacle and the wall outlet. The unit has a universal power supply that should work with local AC power in most countries. If in doubt, check with your power company before plugging it in. In the U.S., the A6 must be plugged into a standard 117 VAC, 50 - 60 Hz outlet.



Do not attempt to use another type of power cable and do not attempt to modify this receptacle or the cable itself. Doing so may cause serious injury or death. Please refer to the section **Important Safety Instructions at the beginning of this manual.**

AUDIO CONNECTIONS

After you've set up the A6 and plugged it into an AC outlet, connect your A6 to a sound system. Since the A6 does not contain an amplifier or speakers, you'll need to connect it to some kind of a sound system in order to hear it. An amp with a full-range speaker will also suffice, as will a stereo music system with external audio inputs. You can also use a pair of standard stereo headphones with a 1/4" TRS plug inserted into the back panel.

For stereo, connect two 1/4" 2-conductor (unbalanced) audio cables from the unit's **LEFT** and **RIGHT** jacks on the rear panel to two inputs on your sound system. For a monophonic output, use an audio cable from the A6's **LEFT** jack. The four **AUX OUT** jacks plus the eight stereo **VOICE OUTPUTS** will be covered in Chapter 4.

For use with stereo headphones, the A6 sports a 1/4" stereo **HEADPHONE** jack on the rear panel.

In any case, turn your A6 on first, then your sound system or amplifier. Use the **MASTER VOLUME** control located near the front panel's upper left-hand corner to set the overall output level of the synthesizer.

PEDALS AND FOOTSWITCHES

Momentary, 2-conductor foot **switches** are used for the **SWITCH** and **SUSTAIN** inputs on the A6's back panel. "Momentary" means that it is a spring-loaded switch that operates by "pressing and releasing" for ON (press) or OFF (release) signals.

A potentiometer, 2-conductor foot **pedal** is used for the **PEDAL/CV** back panel input. This input is typically used for volume or modulation (typically vibrato, but you can use it for other types of modulation). "Potentiometer" means that the pedal mechanically operates an internal knob giving you "more" or "less" rather than ON or OFF like a switch. These pedals are often referred to as "rocker pedals".

MIDI CONNECTIONS

If you plan to use the A6 with other MIDI instruments and devices in a music system, use the following guide to connect it to your rig.

As a Master: If you intend to use the A6 as the master controller in your MIDI rig, plug a standard MIDI cable into the A6's **MIDI OUT** port. The other end of this cable should plug into the **MIDI IN** of the first slave in the system. If there are several MIDI instruments in your setup, connect **MIDI THRU** from the first slave to the **MIDI IN** of the second device and so forth to create a "chain".

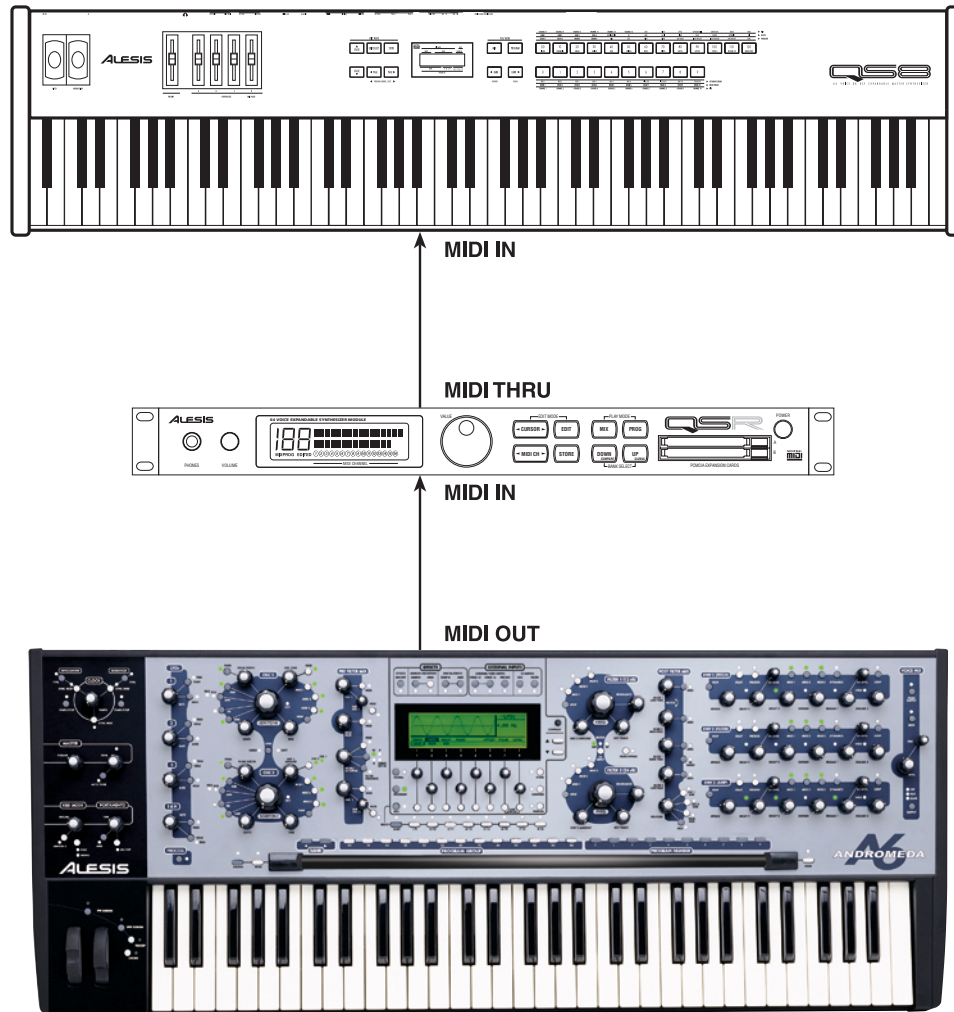

As a Slave:

If you plan to control the A6 from another MIDI device, you'll need a MIDI cable connected to its MIDI IN port.

You will also need a MIDI cable connected to the A6's **MIDI THRU** if you plan to pass MIDI data from the master through the A6 to other MIDI devices in your rig. Connect one end of the MIDI cable to the A6's **MIDI THRU** port and the other end of the cable to the **MIDI IN** of the first device in the chain.

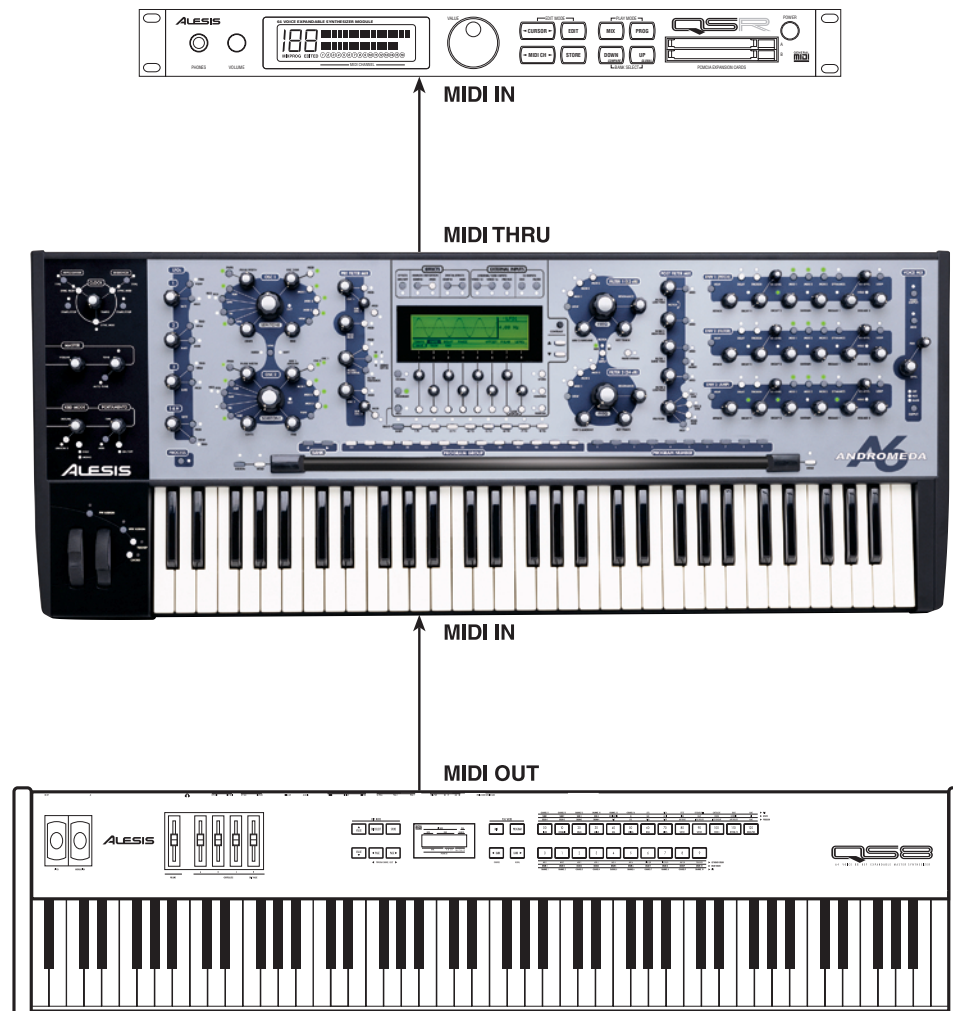

With a MIDI Patchbay:

If you're using a MIDI patchbay or "patcher" to connect all of your MIDI devices centrally, the patcher will have a pair of MIDI connectors for each MIDI device. The patcher's back panel will have a series of paired **MIDI OUT** and **MIDI IN** ports for each device in your rig (the A6 being one of them).

Connect the A6's **MIDI OUT** to the **MIDI IN** of one of the pairs. The same pair's **MIDI OUT** connects to the **MIDI IN** of the A6. Consult the patcher's Owner's Manual to find out how it routes MIDI data among the devices connected to it.

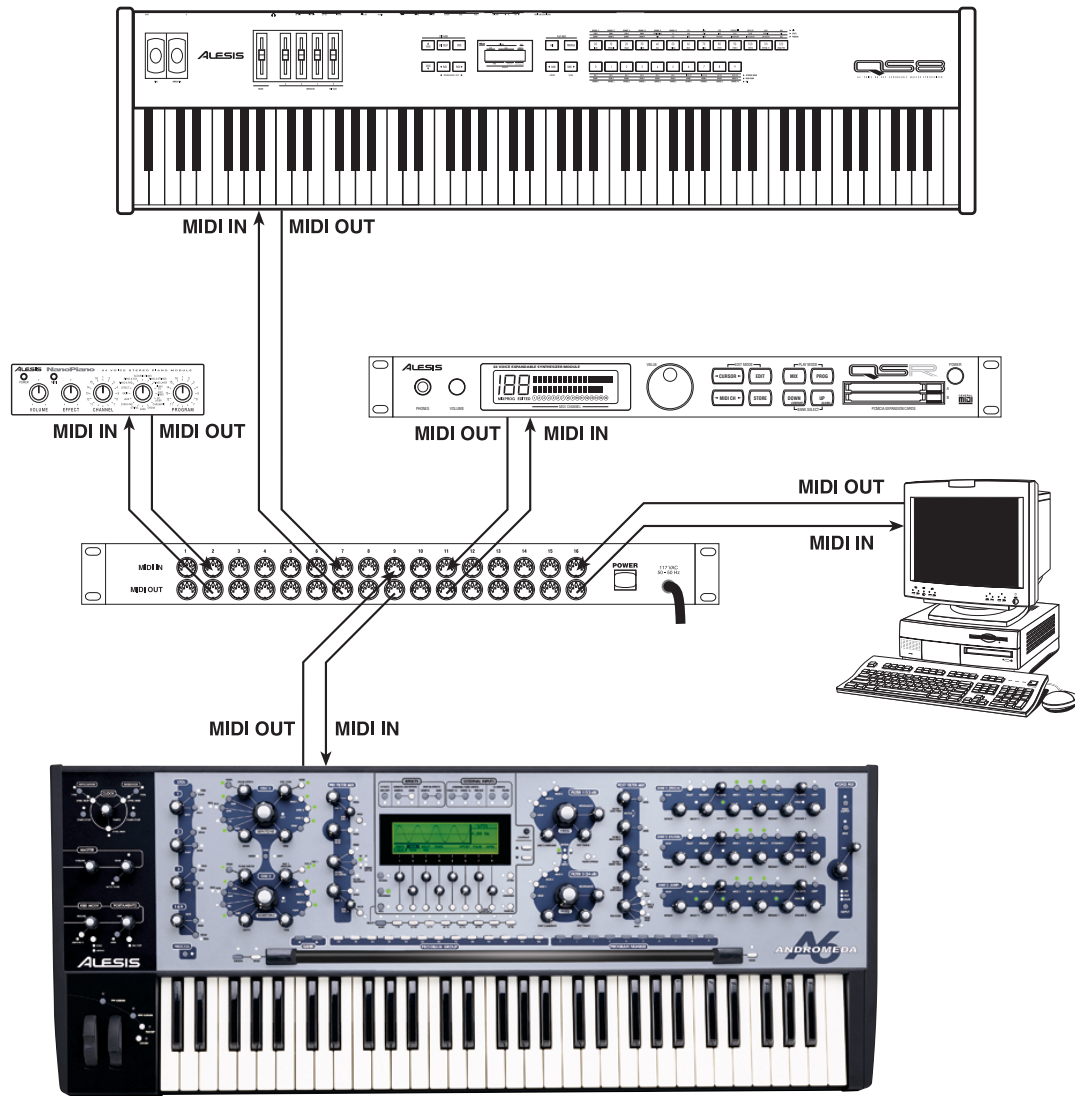

This covers the basics of **setting up** the A6.

QUICK START: PLAYING YOUR FIRST PROGRAM

AUTO TUNE

Now that it's all hooked up, there's one more thing you have to do. If you've jumped the gun and played a few chords, you probably heard that the unit was way out of tune. Because the Andromeda is a true analog synthesizer, and analog circuitry is sensitive to temperature and other factors, each one of the sixteen voices (and the oscillators and filters within each voice) must be tuned before playing. Luckily, the Andromeda has a software routine that will do this for you.

To tune the Andromeda's voices automatically:

On the left side of the control panel above the Mod Wheel, find the MASTER section, with a Volume and a Tune knob. Press the **AUTO TUNE** button beneath these, which will bring up the Auto Tune display. Press **AUTO TUNE** again to start the tuning process.

On the display, you will see each individual oscillator, pulse width, and filter tuned in turn. This takes about three and a half minutes, during which you won't be able to play the unit. (Later, you can save time by tuning only the oscillators if you wish, by pressing the button under OSCFRQ in the display.)

Once the unit is tuned, you'll see a chart showing the results of the tune. A "T" under each voice number shows that the voice was properly tuned. There is one row showing the VCA tune status and one row showing the Oscillator/Filter tune status (more on this later). After the unit has warmed up some more, if you hear something off-key, you may press **AUTO TUNE** again.

The A6 also automatically tunes unused voices in the background without interrupting playing. This is called Background Tuning. In addition, the A6 monitors the temperature of the analog hardware and adjusts tuning to compensate for temperature changes. This is called Temperature Tuning. (More about turning these on and off can be found in later sections of the manual.)

SELECTING PROGRAMS

You don't have to know what all the knobs do to enjoy the A6; it comes pre-programmed with hundreds of sounds. You can simply listen to these sounds and find out more about them later. When playing the A6, the instrument operates in one of two play modes: Program mode and Mix mode. In Program mode, the keyboard plays a single sound across the entire keyboard. Program mode has 3 banks: User, Preset 1, and Preset 2. Each bank has 128 different Programs, so you have a total of 384 Programs to audition. In Mix mode, it may play different sounds in different ranges (a *split*), a stack of sounds on top of each other, or combination of splits and stacks. There are two banks in Mix mode (one User and one Preset) for a total of 256 Mixes. Between the two modes, you have 640 "patches" to select from.

To select Programs and Mixes:

1. To select a Program, make sure that the A6 is in Program mode: the LED next to the **PROGRAM** button should be on. If not, press the **PROGRAM** button.

The easiest method of selecting Programs or Mixes to use the row of direct-select buttons just above the Ribbon Controller. Pressing a 2-digit **PROGRAM GROUP** button selects the "tens group"...



and pressing a single-digit **PROGRAM NUMBER** button selects the specific Program:

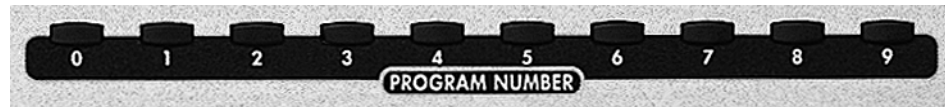

OR

To select a **Mix**, make sure that the A6 is in Mix mode: the LED next to the **MIX** button should be on. If not, press the **MIX** button.

2. To select a specific Program, press a **PROGRAM GROUP** button then a **PROGRAM NUMBER** button. Pressing the "50" button, for example, plus the "8" button selects Program 58, Mix 58, or PROG 58 in a Mix Channel.
3. You can move among Banks by pressing the **< BANK** or **BANK >** button:



For example, when the Andromeda is in **PROGRAM** mode, you have three Program Banks from which to choose Programs: two factory Preset Banks and the User Bank (where you store Programs that you create). Use the **BANK** buttons to switch among these three Banks. Mix Mode works the same: when MIX Mode is active, use the **BANK** buttons to switch among the two Mix Banks (one Preset and one User).

As you change programs, you'll notice various lights on the top panel will change. Disregard this for now.

MASTER VOLUME

And finally, adjust the level using the **MASTER VOLUME** on the **left** side of the control panel. The **VOICE MIX LEVEL** on the right side is a programmable control—it may seem to do the same thing, but avoid using it for now.

The **MASTER VOLUME** knob is a *global* (affects the A6 in all modes) volume control that determines the final output level of the unit's **MAIN LEFT** and **RIGHT** stereo outs, the **HEADPHONE** output and the two **AUX OUTS**. It does not affect the sixteen individual **VOICE OUTPUTS**. To use an audio term, **MASTER VOLUME** is *post* (comes after) the **PRE** and **POST FILTER** mixes and the **VOICE MIX**. This means that any **relative** level settings you make within the Programs and Mixes are preserved.

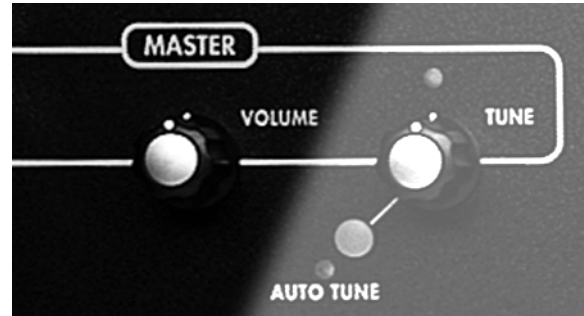

You operate this control by simply turning it: fully counter-clockwise shuts the audio outputs off, fully clockwise is maximum.

The next chapter covers the basics of **playing** the A6: more detail about how to select Programs and Mixes, understanding the various keyboard modes including setting up splits and layers and using portamento, using the performance wheels and the ribbon controller, using pedals and footswitches, and understanding the **CLOCK** section in using the sequencer and arpeggiator.

Chapter 2 will also devote much attention to the display, as it is the central focus of the A6 when operating its controls.

CHAPTER 2:

PLAYING THE A6

Possibly the best way to get acquainted with the A6 is to dig in and start playing. Feel free to skip around this Chapter if you need to get specific information quickly. This Chapter deals specifically with functions you're most likely to use when playing the instrument:

- getting around the front panel
- understanding and using the display
- selecting Programs and Mixes
- setting up splits and layers
- using the Master controls
- exploring the various keyboard modes
- using the performance wheels and ribbon controller
- using pedals and footswitches
- the Clock section: using the sequencer and arpeggiator

Quite possibly the most fundamental skill you'll need to acquire in using the A6 successfully is understanding the display. The essentials of operating the display are covered in this Chapter, and as you use the display on a regular basis, its operation will become much clearer. Once you get a hold of the concepts and procedures laid out in this section, you'll be ready to undertake the remaining tutorials in this book.

The one glaring omission of this Chapter – which is intentional, by the way – is a tutorial on MIDI. If you need an explanation of this technology now, go to Chapter 12. The first half of Chapter 12 is devoted to the MIDI Specification, which serves as a good starting point for those new to this system. Real-world applications with numerous examples in connecting the A6 to other MIDI devices were covered in the previous Chapter.

A BRIEF TOUR OF THE FRONT PANEL

The A6's front panel contains a fairly large number of buttons and knobs, which is probably a lot more than most players are used to seeing on a synthesizer these days. The A6 is designed to make editing as easy and as quick as possible: the majority of Program voice parameters exist on the front panel with a knob or button dedicated exclusively to that function. Having dedicated knobs and buttons achieves the speed goal by not forcing you to dig through layers and layers of functions on the display just to make a simple or routine edit.

The speed of Program editing is enhanced further by the functionality of the display. As we'll discover in the next topic **INTERACTING WITH THE DISPLAY**, the A6's LCD screen employs a set of *soft controls* – controls that change function depending on the current screen. These eight buttons and eight knobs are used to edit whatever is being displayed. Therefore, the display area provides a **second** location where Program editing can happen.

So you have a choice: you can make Program edits directly from any front panel control, or you can do it in the display area. In either case, the display will change to reflect the current edit you're making. You can even lock the display so that it **doesn't** switch every time an edit is attempted. More on that later.

HOW FUNCTIONS ARE GROUPED

Understanding how the A6's functions are grouped will greatly enhance your ability to learn and use the instrument. The following topics describe these function groups – called *modules* – of the A6.

Program-Specific Functions

There are numerous functions within the A6 that deal only with the creating or editing of Programs. In fact, most of the controls on the front panel that are in the area above the keyboard (not including the display area) are Program functions. The front panel is laid out such that each Module and its related parameters are visually grouped by the artwork:

LFOs
PROCESS
OSC 1
OSC 2
PRE FILTER MIX

Display and Soft Controls*
EFFECTS*
EXTERNAL INPUTS*

* also available for Mixes.

FILTER 1
FILTER 2
POST FILTER MIX
ENV 1 (PITCH)
ENV 2 (FILTER)
ENV 3 (AMP)
VOICE MIX

These functions will be covered in detail in **Chapter 4: A6 Overview** and **Chapter 5: Program Functions**. But of particular importance to note now, especially for seasoned analog synthesists who are familiar with earlier modular products, is that each of the above function groups can be thought of as a “physical module minus the patch cords”. In fact, you can “disconnect” some of these modules from the audio and control paths by setting their values to zero, in effect turning them off. That's why they're called “modules”.

Mix-Specific Functions

Mix mode, because of its nature in simply organizing existing Programs into splits, layers and other Voice arrangements, has far fewer controls than those for constructing the Programs themselves. Notice that Mix controls are conspicuously absent from the A6's front panel – you access these functions from the display. The basics of layering and splitting are covered later in this chapter on page 47.

Mix mode is also used when the A6 is connected to a MIDI sequencer for multitimbral recording and playback. Each Mix *channel*, the set of parameters that are used to control a Program in the Mix, can be assigned to a specific MIDI Channel with unique MIDI controller assignments.

Especially noteworthy of Mix mode is that it has its own set of programmable effects. All of the effects available for enhancing Programs are included in this mode and are fully independent and programmable per Mix. This is particularly useful when constructing complex Mixes that use many different Programs. These functions are covered in detail later in this manual in **Chapter 11: Mix Mode**.

Global Functions

Global functions are those that affect the A6 no matter what mode it's in. You can think of global functions as "master" controls such as **MASTER VOLUME** or **MASTER TUNE**.

Also, there are certain MIDI functions that are global as well. Every MIDI instrument or device has a setting called the Basic MIDI Channel. This sets the Channel on which the instrument will normally transmit MIDI data, although the "upper" and "lower" components of splits and layers can be set to transmit and receive on Channels other than the Basic. Global Mode is covered later in this Chapter on page 49, **Using Global Mode**. But first, let's become familiar with the Andromeda's display and soft controls.

INTERACTING WITH THE DISPLAY

Although the A6 has numerous knobs and buttons across its front panel, the display (and its associated controls) is the central area to use when operating the A6. This concept holds true in all modes: with few exceptions, virtually every front panel knob and button are duplicated on-screen, and most of them will show their current settings if appropriate.

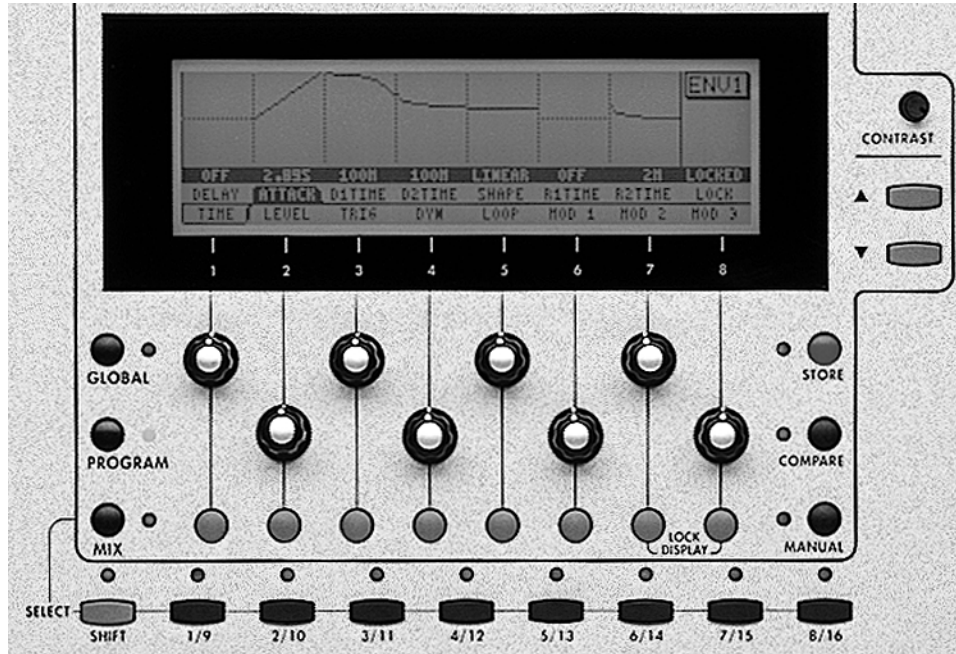

DISPLAY FEATURES

As a general principle, the display will group a function's parameters together on the screen. This makes creating and editing Programs and Mixes much easier, as is getting around in Global mode.

A group of parameters on the screen is called a display *page*. Some A6 functions have more than one page because they have more parameters than can be displayed in the available screen area. This is called a *multi-page* display and the active page's title is displayed on a page *tab* which resembles a tab in a notebook. The active parameter's title is displayed in white characters with a black-highlighted tab. This way, you will always know which page and which parameter on that page is active.

In addition, the display's usefulness is enhanced by depicting certain functions with a graphic. Furthermore, the picture changes as you make adjustments to its parameters. Envelope shapes, LFO waves and Velocity curves are displayed in graph form, just to name a few. A visual representation of the item(s) you're changing not only makes the editing process faster, it will (in many cases) assist you in understanding the functionality of the parameters you're working with.

BASIC DISPLAY FUNCTIONS

In its normal operating mode, **the display will react to virtually any change you make to any of the front panel controls**. When you turn a knob or press a button, the display will recall that parameter's page and select the parameter for editing. This feature of the A6 will save you an enormous amount of time and frustration when making changes and minimizes the risk of "getting lost" when editing many parameters at the same time.

While this feature of the A6 is quite useful when working with individual **parameters**, you may want to display a particular **module**. In this case, press its **VIEW** button. This will display the selected module – **OSC 1, OSC 2, FILTER 1, FILTER 2, ENV 1, ENV 2** or **ENV 3**, etc. – and the last parameter that was used in that module will be the active one. You can then proceed to make your edits from either the screen's controls or the module's dedicated front panel controls.

The advantage of the **VIEW** button is that **you can select a module and view its current settings without changing any of its parameters**. If you turn one of the front panel knobs, its value will change. So if you just want to **see** the module's current settings without making changes, use the **VIEW** button.

On the other hand, the advantage of a module's dedicated front panel controls is that **you can make edits to its most commonly used parameters quickly** just by turning a knob. The choice is yours.

Soft Controls

Directly beneath the display is a series of eight untitled knobs and buttons numbered **1** through **8**. These are *soft* controls – controls that change function depending on the current screen. Soft controls, therefore, obtain their functional identity or "personality" from the pages and parameters being displayed: the current function of any knob or button is determined by what is on the display **directly above** the control. There are three rows in most displays:

- the **bottom** row of the display is called the *Page Row*. It shows the names of display pages that can be called up by pressing the **button** beneath the **page tab**.
- the **second** row of text shows the function of each **knob**. We'll refer to this row of text as the *Parameter Row*.
- the **third** row of text (in **reversed text like this**) shows the current **value** of each parameter. We'll refer to this row of text as the *Value Row*.

Tip: Although you can select any parameter simply by turning its corresponding soft knob, this action also changes the parameter's value which isn't always desirable. Sometimes you just want to review the current settings of the parameters on a page without changing anything. On many pages, you can select a parameter **without** changing its value by pressing its page's soft button.

Modes of Operation

Let's start at the beginning and discuss the three basic operating modes of the A6 and how the display keeps you informed of what's going on.

All of the operations of the A6 are grouped into three operating modes: Program mode, Mix mode and Global mode. You can access only one of these modes at a time, but switching among the three is as easy as pressing a button.

Use the three buttons on the lower left-hand corner of the display area to initiate the desired mode. When pressed, a mode button's associated LED will light:

- pressing **PROGRAM** initiates Program mode where the A6's single programs are played via the keyboard or MIDI, and where you edit existing Programs or create new ones from scratch. This is one of the A6's two **Play** modes; the other one is Mix mode, described next.
- pressing **MIX** initiates Mix mode where the A6's Mix programs are played via the keyboard or MIDI, and where you edit existing Mixes or create new ones from scratch. **A Mix is made up of existing single Programs** and is the mode you use for creating layers, splits or complex sound combinations, and for MIDI control.
- pressing **GLOBAL** initiates Global mode where you control the A6's global functions and master settings. These functions affect the A6 regardless of what Play mode the A6 is in. Included in this mode are items such as setting the MIDI Basic Channel and MIDI Controller Numbers, monitoring voice activity, and so forth.

Data Banks: How the A6's Sounds Are Organized

The following block diagram illustrates how the A6's memory is organized among the three operating modes we just discussed.

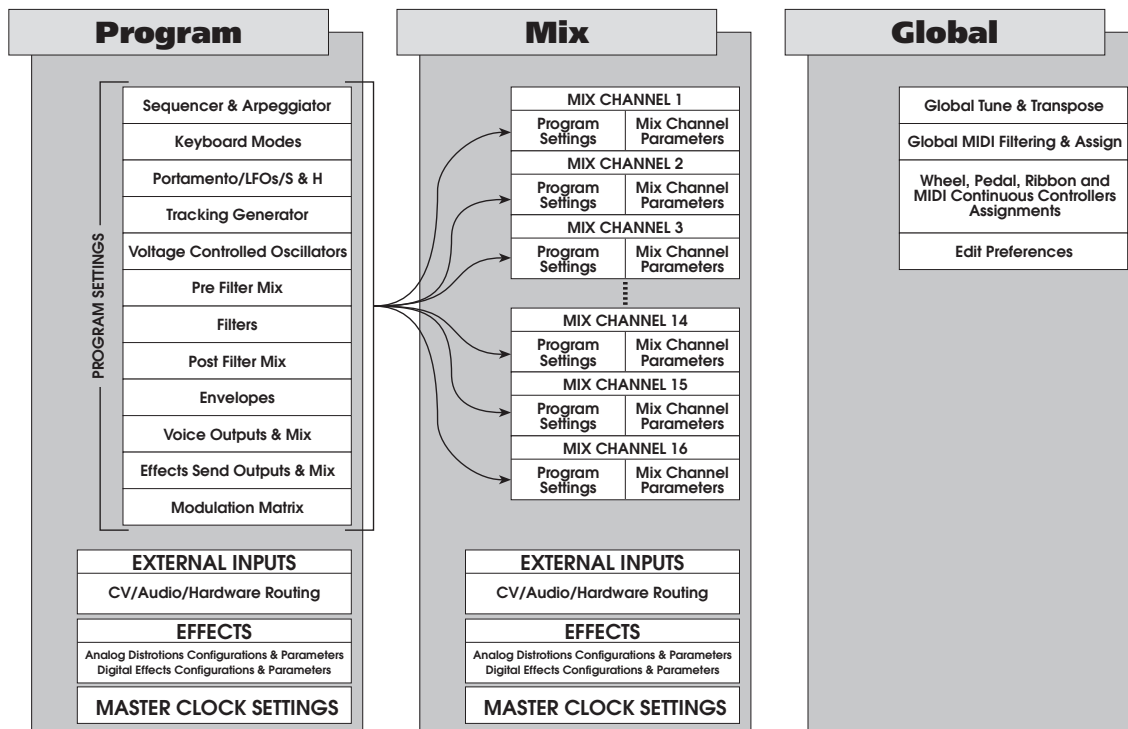

Throughout this manual, we'll be using the following terms to describe the memory capabilities of the A6:

- A *Program* bank refers to an entire bank of Programs.
- A *Mix* bank refers to an entire bank of Mixes.
- A *User* bank (there's one for Programs and one for Mixes) refers to a data bank that uses RAM for storage and can be edited. You can think of this of bank as your "work space": individual Programs and Mixes can be edited and stored, replaced, copied and so forth.
- A *Preset* bank refers to a data bank – either Program or Mix – in Flash ROM. The A6's Preset banks (there are three of them) are commonly called "factory presets" on many other instruments. These banks – two Preset Program banks and one Preset Mix bank – contain Programs and Mixes developed for the A6 by the Alesis Sound Design team.

Unlike Preset banks in many other synths, the A6's Preset banks can be customized by the user, but only as an Entire Bank copy operation. This means that, unlike the User banks, you cannot selectively copy just one Program or Mix to this bank. The entire bank must be over-written at once.

- A *Card* bank refers to a data bank of memory provided by a PCMCIA card in the A6's back-panel card slot. An SRAM card allows the same options for storage as found for the User bank. The card may allow for a Program Bank only, several Mix banks, or a combination, depending on its size.

The A6's memory capacity is arranged as follows:

Program mode:

- 2 Preset Program banks of 128 Programs (256 total)
- 1 User Program bank of 128 Programs

Mix mode:

- 1 Preset Mix banks of 128 Mixes each
- 1 User Mix bank of 128 Mixes

Memory Functions

Each of the two play modes – Program and Mix – contain two memory functions that are used when editing existing Programs or Mixes, or creating new ones. When pressed, a memory button's associated LED will light:

- the **STORE** button allows you to save a Program or Mix that you've edited or created into the current program number, or copy it to another memory location. The procedure for saving edited Programs and Mixes is detailed on page 43.
- pressing **COMPARE** recalls the stored version of the Program or Mix you're editing so that you can compare the edited version with the original. This button is inactive if the current program hasn't been edited (there's nothing different to compare).

Program mode contains a third memory-related function called **MANUAL** that's used when creating new Programs and is only active in Program mode. Pressing this button causes the A6 to exit the current Program and create a new Program based on the current settings of all front panel controls. While this new program may not sound like anything useful – the knobs could be positioned in strange settings – it provides a good starting point for a new program.

LOCK Function

While many of the A6's pages make use of all eight knobs and buttons, many do not. You may notice that sometimes knobs and buttons will become inactive because the display doesn't need them. But there are two soft buttons – **7** and **8** – that are always active. They are used to lock the display.

As mentioned at the beginning of this topic, the display will react to virtually any change you make to any of the front panel controls. This causes a lot of display switching and can be distracting. If you want to prevent the display from switching screens when performing numerous edits, press soft buttons **7** and **8** together. This will lock the display in its current screen, and **DISPLAY LOCKED** will flash over soft knobs 4 and 5. You can continue to make adjustments to any parameter, but the display stays put. Press **7** and **8** again (or any **VIEW** button) to turn this function off.

▲ and ▼ Arrows

For the majority of parameters in the A6, numeric values are displayed with fractional amounts, represented by the digits to the right of the decimal point. This allows for very precise adjustments to be made to parameters that support fractional values. The ▲(increment) and ▼(decrement) arrows are used to make fine adjustments to any parameter that is displayed with a fractional value.

Holding an arrow down scrolls the values. You'll notice that the changing values will accelerate the longer you hold the arrow button down.

Double-Arrow Reset

Pressing both arrow buttons together will either set the selected parameter to zero or to a useful default or neutral value. For example, if the **SQR** wave's **WIDTH** parameter is selected, pressing both arrows together sets its value to 50%. If **FILTER 2 KEY TRACK** is selected, pressing both arrows together sets its value to 50. Generally, most parameters with a 0 to 100 or a -100 to +100 range will reset to 0.

CONTRAST Control

The **CONTRAST** knob above the ▼ and ▲ arrows is used to adjust the contrast of the display.

The MIX SELECT Button Group

The row of rectangular buttons just below the display area are used to select the Programs within a Mix. When a Mix Channel is **ON**, its associated LED will light. When a Mix Channel is currently selected for editing in the display, its LED will blink.

When the A6 is in Mix mode, pressing one the **1/9** through **8/16** buttons selects a specific *Mix Channel* – the group of settings that affect each Program in a Mix (the Program number, its transpose value, its individual MIDI Channel, etc.). Pressing a numbered button alone selects Mix Channels **1** through **8**. Pressing and holding **SHIFT** while pressing a numbered button selects Mix Channels **9** through **16**.

Table of Display Functions

The following table summarizes the functions of the display's knobs and buttons:

| NAME | FUNCTION |
|--|--|
| GLOBAL button | Enters Global mode, displays Global screen. |
| PROGRAM button | Enters Program mode, displays Program screen. |
| MIX button | Enters Mix mode, displays Mix screen. |
| STORE button | Enters Store mode, Copy mode for Programs, Banks, and Effects, SysEx mode, and the INIT function used to reset the A6 User banks; displays the screens associated with each of the above functions. |
| COMPARE button | Enters Compare mode: when editing, the stored versions of the current Program or Mix (including Distortion and Effects) are recalled permitting a comparison to be made with the edited versions. |
| MANUAL button | Enters Manual mode: every knob position on the front panel is read by the A6 and made current. |
| MIX button group | Group of buttons for selecting the current Mix Channel within a Mix: |
| SHIFT button | Toggles between the Mix Channels 1-8 and 9-16. |
| 1/9 – 8/16 buttons | Pressing once selects the desired Mix Channel. For the current Mix Channel, pressing again toggles the Mix Channel on or off. When a Mix Channel is on, its button's LED will blink when that Mix Channel is selected. |
| "Soft Buttons" | Eight buttons below the display that select the page shown on the Page row (the lowest row of text in the display). |
| "Soft Knobs" | Eight knobs below the display whose functions are determined by what is currently being displayed on the second row of text from the bottom (the Parameter row) . |
| ▲ and ▼ buttons | Step adjusts the highlighted value for the current parameter. Pressing both arrows together resets the current parameter to zero, a midpoint or a useful default value |
| LOCK DISPLAY button combination | Soft Buttons 7 and 8 pressed together will lock the current display screen. The words DISPLAY LOCKED will flash in the display. |

SELECTING PROGRAMS AND MIXES

When playing the A6, the instrument operates in one of two play modes: Program mode or Mix mode. One method of selecting Programs or Mixes is using the row of direct-select buttons just above the Ribbon Controller. Pressing a 2-digit **PROGRAM GROUP** button selects the “tens group”...



... and pressing a single-digit **PROGRAM NUMBER** button selects the specific Program or Mix:

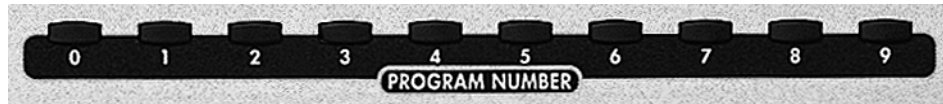

1. To select a Program, make sure that the A6 is in Program mode: the LED next to the **PROGRAM** button should be on. If not, press the **PROGRAM** button.

OR

To select a Mix, make sure that the A6 is in Mix mode: the LED next to the **MIX** button should be on. If not, press the **MIX** button. Also, in Mix mode you can work with the individual Programs that are contained **within** a Mix (the individual Programs that comprise a Mix are referred to as *Mix Channels*).

2. To select a specific Program, Mix or assign a Program to a Mix Channel, press a **PROGRAM GROUP** button then a **PROGRAM NUMBER** button. Pressing the “50” button, for example, plus the “8” button selects Program **58** when the A6 is in Program mode, Mix **58** when in Mix mode or assigns Program 58 to the selected Mix Channel when Mix mode’s **PROG** page is displayed. See the next paragraph for details:
3. To assign a specific Program to a specific Mix Channel within a Mix, press **MIX** to enter Mix mode, then press one of the **SELECT** buttons to select a Mix Channel. Press soft button 6 to display Mix mode’s **PROG** page. **While the PROG page is being displayed**, pressing a **PROGRAM GROUP** and/or a **PROGRAM NUMBER** assigns that Program to the current Mix Channel. Don’t forget to turn the Mix Channel on (press the Channel’s **SELECT** button if its LED is off).
4. You can move among Banks by pressing the **< BANK** or **BANK >** button:



When the Andromeda is in Program mode, you have three Program Banks from which to choose: two factory Preset Banks and one User Bank (where you store Programs that you create). Use the **BANK** buttons to switch between these Banks. Mix Mode works the same: when MIX Mode is active, use the **BANK** buttons to switch among the two Mix Banks (one Preset and one User).

The second method of selecting a Program, Mix or Mix Channel involves the display and soft knobs and is covered in the next topic.

PROGRAM MODE PARAMETERS

Pressing the **PROGRAM** button displays the Program mode display screen. As with all other A6 functions, the page and parameter that was last selected will be recalled. The following table summarizes the Program mode parameters:

| SOFT KNOB → | 1 | 2 | 3 | 4 | 5 | 6 | 7 | 8 |
|-------------|------|--------|---|---|---|---|---|---|
| ↓ PAGE TAB | | | | | | | | |
| PROG | BANK | NUMBER | | | | | | |
| DIR | BANK | NUMBER | | | | | | |

PROG and DIR Page Parameters

The **PROG** (Program) page provides another method to select Programs in addition to the Direct Select buttons. When this page is being displayed, use soft knob 1 to select the bank and soft knob 2 to select the specific Program number.

The **DIR** (Directory) page soft knobs operate the same as in the **PROG** page. The difference is that the **DIR** page provides a directory-style listing of all Programs in the synthesizer, and shows ten names at a time.

Tip: While either of these two pages are being displayed, you can still use the Direct Select buttons as well as the soft knobs to select sounds.

MIX MODE PARAMETERS

Pressing the **MIX** button displays the Mix mode display screen. As with all other A6 functions, the page and parameter that was last selected will be recalled. The following table summarizes the Mix mode parameters:

| SOFT KNOB → | 1 | 2 | 3 | 4 | 5 | 6 | 7 | 8 |
|-------------|--------|--------|--------|--------|--------|---------|--------|---------|
| ↓ PAGE TAB | | | | | | | | |
| MIX | BANK | NUMBER | | | | | | ENABLE |
| MIXDIR | BANK | NUMBER | | | | | | |
| | | | | | | | | |
| KBD | KBD LO | KBD HI | | ENABLE | | | | |
| PROG | LEVEL | PAN | OUTPUT | SEMI | CENTS | MIDI CH | | |
| | | | | | | | | |
| CNTL | PCHWHL | MODWHL | AFTCH | SUSPDL | EXTSW | EXTPDL | RIBBON | - KBD - |
| | | | | | | | | |
| SOLO | MID IN | MIDOUT | MID CC | MIDVOL | MIDPGM | MIDAFT | | |

The **DIR** page in Mix mode operates exactly the same as the parameters in Program mode. For descriptions of this parameter, see above.

The pages unique to Mix mode are MIX, KBD, PROG, CNTL and SOLO, described as follows:

MIX Page Parameters

| PAGE | PARAMETER | OPTIONS or RANGE | DESCRIPTION |
|------|-----------|----------------------|---|
| MIX | BANK | - USER - PRESET 1 | This parameter displays the current Mix Bank. Use soft knob 1 or the BANK select buttons to change Banks. |
| | NUMBER | 000 ... 127 | This parameter displays the number of the current Mix in the current Mix Bank. Use soft knob 2 or the PROGRAM GROUP and PROGRAM NUMBER buttons to change Mixes. |
| | ENABLE | ON, OFF | Use soft knob 8 to turn the currently selected Mix Channel on or off. |

KBD Page Parameters

The abbreviation for “Keyboard,” this Mix page contains parameters that determine the keyboard range of the current Mix Channel and allow you to turn the keyboard’s control of the Mix Channel on or off.

| PAGE | PARAMETER | OPTIONS or RANGE | DESCRIPTION |
|------|-----------------------------|---------------------|---|
| KBD | KBD LO Low note limit * | C0 ... G10 | The lowest note on the keyboard that this Mix Channel will play on. |
| | KBD HI High note limit * | C0 ... G10 | The highest note on the keyboard that this Mix Channel will play on. |
| | ENABLE | ON, OFF | Turns keyboard control of this Mix Channel on or off. This is useful for setting up a Mix Channel to be played by MIDI In only and not to be affected by the A6’s keyboard. |

* The KBD LO and KBD HI settings define the *keyboard range* or *zone* of the Mix Channel. These are the parameters you use when setting up splits and layers, as well as other specialty keyboard configurations. See page 47 later in this Chapter for the full story.

PROG Page Parameters

The abbreviation for “Program,” this page is where you set the level, pan and output jacks, transpose and fine tuning amounts, and MIDI Channel settings for the selected Mix Channel.

This is also where you can select a Program for the Mix Channel using the **PROGRAM GROUP** and **PROGRAM NUMBER** buttons.

| PAGE | PARAMETER | OPTIONS or RANGE | DESCRIPTION |
|------|-----------|------------------------|--|
| PROG | LEVEL | 0 ... 100 | Sets the output level of the current Mix Channel. |
| | PAN | -100 ... +100 | Sets the “placement” of the Mix Channel’s output in the left-to-right stereo panorama. -100 is full left, +100 is full right and 0 is center. |
| | OUTPUT | - OFF - MAIN AUX | Routes the audio output of the current Mix Channel to either the rear panel MAIN output jacks, the AUX jacks or off. Note that the headphones will be active only when MAIN is selected in the display. |
| | SEMI | -60 ... +60 | Sets the transpose amount of the current Mix Channel in semi-tones, ± 5 octaves. |
| | CENTS | -100 ... +100 | Sets the transpose amount of the current Mix Channel in semi-tones, ± 5 octaves. |
| | MIDI CH | 1 ... 16 | Sets the MIDI Channel that the current Mix Channel will use to send and receive. |

CNTL Page Parameters

The abbreviation for “Controllers”, this page permits you to enable/disable local and MIDI controllers for the selected Mix Channel.

The parameters on this page determine whether or not the displayed controllers affect the currently selected Mix Channel. Use the parameter’s corresponding soft knob to turn the function on or off.

| PAGE | PARAMETER | OPTIONS or RANGE | DESCRIPTION |
|----------------|-----------|------------------|---|
| CNTL Page 1 | PCHWHL | ON, OFF | Enables, disables the A6’s Pitch Wheel. |
| | MODWHL | ON, OFF | Enables, disables the A6’s Modulation Wheel. |
| | AFTCH | ON, OFF | Enables, disables keyboard Aftertouch. MIDI In aftertouch is turned off or on in Page 2, below. |
| | SUSPDL | ON, OFF | Enables, disables the rear panel SUSTAIN jack and MIDI In sustain pedal control. |
| | EXTSW | ON, OFF | Enables, disables the rear panel SWITCH jack. |
| | EXTPDL | ON, OFF | Enables, disables the rear panel CC PEDAL jack. |
| | RIBBON | ON, OFF | Enables, disables the A6’s Ribbon Controller. |
| | - KBD - | ON, OFF | Enables, disables the A6’s keyboard. |

The CNTL parameter group contains 16 parameters, displayed eight at a time. Press soft button 7 to toggle between the two display sub-pages.

| | | | |
|----------------|--------|---------|---|
| CNTL Page 2 | MID IN | ON, OFF | Enables, disables MIDI In control of the current Mix Channel. |
| | MIDOUT | ON, OFF | Enables, disables MIDI Out control from the current Mix Channel. |
| | MIDCC | ON, OFF | Enables, disables MIDI continuous controller commands such as sliders and knobs on another MIDI device. |
| | MIDVOL | ON, OFF | Enables, disables MIDI volume control. |
| | MIDPGM | ON, OFF | Enables, disables MIDI program change commands. |
| | MIDAFT | ON, OFF | Enables, disables MIDI Aftertouch. |

SOLO function

This is not a “page”, actually; you can press Soft Button 8 to solo a Mix Channel when you’re on any of the pages of Mix mode. This “solos” the currently selected Mix Channel (indicated by the green blinking LED over the SELECT button) so you can concentrate on one layer of a Mix without hearing the others.

STORING EDITED PROGRAMS AND MIXES

Chapters 5 through 8 explore the details of editing existing Programs and Mixes, and provide all the information for creating completely new ones. When a Program or Mix has been edited or a new one is created, you'll need to save your work. This is where **STORE** mode comes in.

STORE mode allows you to save into the **current** Program or Mix number (also referred to as a *memory location*), or **copy** it to another memory location in the User or Card bank. Note that you cannot store to a memory location in any Preset bank.

STORE MODE PARAMETERS

| SOFT KNOB → | 1 | 2 | 3 | 4 | 5 | 6 | 7 | 8 |
|-------------------|-------|---------|---------|---------|-------|---------|----------|---------|
| ↓ PAGE TAB | | | | | | | | |
| PROG ¹ | BANK | NUMBER | | | | | | |
| DIR | BANK | NUMBER | | | | | | |
| COPY | TYPE | SRCBANK | SRCNUM* | MIXCHN* | | DSTBUF* | DSTBANK* | MIXCHN* |
| INIT | PROGS | MIXES | | | | | | |
| SYSEX | BANK | NUMBER | RCV-TO | SEND | | | | |
| CARD | INIT | | | | | | | |
| NAME | BANK | NUMBER | CHAR | 0-9 | UPPER | LOWER | NAMES | <- -> |

¹ The first tab, displayed here as **PROG**, shows that the A6 is in **STORE** mode for Programs. When the A6 is in **STORE** mode for Mixes, this tab will display **MIX**.

* These parameters appear in the **COPY** page depending on the **TYPE** chosen.

TO STORE A PROGRAM OR MIX TO MEMORY:

1. Press **STORE**. For Programs (Mixes), the screen will display the message:

```
SELECT PROGRAM (MIX) AND BANK AND HIT STORE TO SAVE
```

2. To store the current edited version of a Program or Mix to the **same** memory location, press **STORE** again. **This will overwrite the old version of the Program or Mix that is currently in this (User or Card) memory location.**
3. To store an edited Program or Mix to a **different** memory location, use soft knob 1 (or the **BANK** buttons) to change Banks and use soft knob 2 (or the **PROGRAM GROUP** and **PROGRAM NUMBER** buttons) to change the Program or Mix number. The press **STORE** again. **This will overwrite the Program or Mix that is currently in this User or Card memory location.**

To abort the store, press either the **PROGRAM** or the **MIX** button.

If you want to re-arrange the order of Programs and Mixes, you can use this procedure to copy Programs and Mixes that you just want to move around – they don't have to be edited to be copied. On the other hand, the **STORE** function has a **DIR** page and a **COPY** page that are designed to make these operations easier as described below.

DIR Store Procedure

When you press the **STORE** button the first time to initiate a store, you can press soft button 2 to enter the DIR (“Directory”) page. Here you can view the entire list of 128 Programs or Mixes **by name**. This way, if you want to store a Program or Mix to another memory location, you can see in advance which Program or Mix will be overwritten.

Use soft knob 2 to select the destination Program (or Mix). Press **STORE** again to complete the store. **To abort the store, press either the PROGRAM or the MIX button.**

COPY Page Parameters

| PAGE | PARAMETER | OPTIONS or RANGE | DESCRIPTION |
|------|------------------------------|--|---|
| COPY | TYPE | PRG BANK MIX BANK | Copy the entire Program/Mix Bank to the Destination Bank. <i>This is the only way to change a Preset Bank.</i> |
| | | PRG DFX MIX DFX | Copy the Digital Effects parameters of the selected Program or Mix to the selected Edit Buffer. |
| | | PRG AFX MIX AFX | Copy the Analog Distortion parameters of the selected Program or Mix to the selected Edit Buffer. |
| | | MIX CHAN | Copy a Mix Channel to a different Mix Channel in the Edit Buffer. |
| | SRCBANK Source Bank | USER PRESET 1 PRESET 2* CARD* | Selects the Bank you want to copy from. |
| | SRCNUM Source Number | 0-127 | Selects the number of the Program or Mix you want to copy from. <i>This has no effect in Program or Mix Bank copy mode.</i> |
| | DSTBANK Destination Bank | USER PRESET 1 PRESET 2* CARD* | Selects the Bank you want to copy to, that will be overwritten by pressing COPY then STORE . <i>Appears only in Program or Mix Bank copy mode.</i> |
| | DSTBUF Destination Buffer | MIXBUF PRGBUF | Selects the Edit Buffer you want to copy to, that will be overwritten by pressing COPY then STORE . <i>Appears only in Program or Mix DFX or AFX copy mode.</i> |
| | MIXCHAN Mix Channel | 1-16 | In MIX CHAN COPY mode, this appears in two places. Turn Soft Knob 4 to select the source, and Soft Knob 8 to select the destination Mix Channel. |

* There is no Preset 2 option when a Mix is the source, and no Card unless an initialized card is in the memory slot.

COPY Procedure

To copy an item, press **STORE** then press soft button **3**. Use soft pot knob **1** to select the type of item to copy (Program Bank, Program Digital FX settings, etc.) Select the source using soft knob **2**. Select the destination using soft pot **7**. Press **STORE** twice to execute the copy.

INIT Procedure

You can *initialize*, or reset, all Programs in the User Bank to the – A6 Default Program –, a program that returns all program settings to their default values resulting in a basic, rather “plain” sounding Program. By the same token, you can reset all Mixes to their default values as well.

To accomplish this, press **STORE** then press soft button **4**. To initialize all Programs, turn soft knob **1**; to initialize all Mixes, turn soft knob **2**. In either case, the display will prompt you to press **STORE** again to complete the reset. **To abort the initialization, press either the PROGRAM or the MIX button.**

Be careful: initialization cannot be reversed. There is no “Undo” like there is on personal computers.

Storing Programs and Mixes using the SYSEX Page

To store Programs and Mixes to an external MIDI device such as a sequencer or MIDI data storage device, use a System Exclusive dump. You can set the kind of SysEx dump you want to send by pressing Soft Button **5**, the **SYSEX** page of Store mode. This page is also where you set how SysEx messages will be received. For details on using System Exclusive messages for storing to an external MIDI device, see **Chapter 12: MIDI**.

CARD Page

You can expand the Program/Mix memory of your Andromeda by plugging in PC Card Type 1 SRAM cards, available from your Alesis dealer. The **CARD** page will show you the size and type of card currently in the memory slot on the rear panel. The only other function of the page is **INIT**, used primarily when a card is brand new and needs to be initialized to the A6’s card format, but also to erase all Programs or Mixes on a card.

TO INITIALIZE A CARD:

1. Insert a PCMCIA Type 1 SRAM memory card (from 256k to 2MB in size) into the card slot on the back of the unit.
2. Press **STORE**. Press Soft Button **6**, **CARD**.
3. Turn Soft Knob **1** (**INIT**) all the way around until "HIT STORE TO INIT RAM CARD" shows in the display.
4. Press **STORE**. Follow the prompts for whether you want the card to store only Programs, Mixes, or both. (These may not be available if the card is less than 512k in size.)

NAME Page Parameters

The **NAME** page contains parameters that allow you to quickly and easily change the name of the selected Program or Mix. In addition, you can also change the destination Bank and Program/Mix number like you can in the **PROG** page.

| PAGE | PARAMETER | OPTIONS or RANGE | DESCRIPTION |
|------|-----------|----------------------|---|
| NAME | BANK | - USER - PRESET 1 | This parameter displays the current Program or Mix Bank. Use soft knob 1 or the BANK select buttons to change Banks. |
| | NUMBER | 000 ... 127 | This parameter displays the number of the current Program or Mix in the current Bank. Use soft knob 2 or the PROGRAM GROUP and PROGRAM NUMBER buttons to save to a different Program or Mix number. |
| | CHAR | SPACE - z | Use soft knob 3 to select a character. |
| | 0-9 | 0 - 9 | Use soft knob 4 to select numerals 0 through 9 only. |
| | UPPER | A ... Z | Use soft knob 5 to select upper-case letters A through Z only. |
| | LOWER | a ... z | Use soft knob 6 to select lower-case letters a through z only. |
| | NAMES* | Various (see below) | Soft knob 7 allows you to select from among a list of 89 preset Program/Mix names to save you time. |
| | <- -> | | Use soft knob 8 to select the character you want to change. |

* The names available for selection are:

| | | | | | | | | |
|---------|-----------|---------|----------|---------|----------|----------|---------|----------|
| Alien | Boomy | Dark | Fretless | Lonely | Oboe | Reverse | String | Trash |
| Analog | Brass | Decay | FM Mod | Loose | Pad | RingMod | Stupid | Twisted |
| Angry | Bright | Deer | Guitar | Lost | Phat | Sax | Sync | Unison |
| Another | Chromatic | Delayed | Horns | Low | Plucked | Sequence | Synth | Velocity |
| Awesome | City | Dinky | Hammer | MIDI | Piano | Simple | Technox | Violin |
| Arpeg | Crash | Dual | Hard | Monster | Piercing | Sloppy | Timed | Watery |
| Attack | Crispy | Edge | Harp | Moon | Porta | Slow | Thick | Whirling |
| Bass | Crying | Fast | Harmonic | Morph | PW Mod | Solo | Thunder | Whistle |
| Bell | Cutting | Fat | Junky | Octave | Random | Soft | Tight | Zither |
| Blues | Cymbal | Flute | Leslie | Organ | Retro | Sparkle | Tov | Blank |

SETTING UP SPLITS AND LAYERS

Splits and layers are constructed from Mix Channels in Mix mode. So make sure that the A6 is in Mix mode: the LED next to the **MIX** button should be on. If not, press the **MIX** button.

TO SET UP LAYERS OF PROGRAMS IN MIX MODE:

To create a layer, we'll "stack" one Mix Channel on top of another. This is accomplished by assigning the same keyboard range to both Mix Channels. This effectively creates **two** note commands for every **one** key that is played on the A6's keyboard:

1. Press the **1/9** button. The display will show you the **STATUS** of Mix Channel 1 on the right side of the screen. If **OFF**, press the **1/9** button again or use soft knob **8** to turn Mix Channel 1 **ON**. The LED above the **1/9** button will blink.
2. Do the same for Mix Channel 2: press the **2/10** button. If the the status of Mix Channel 2 is **OFF**, press the **2/10** button again or use soft knob **8** to turn Mix Channel 2 **ON**. The LED above the **2/10** button will blink; the LED above the **1/9** button will light steady.
3. We only want to use two Mix Channels, so make sure that the LEDs above the remaining **MIX SELECT** buttons are off. Also, press the **SHIFT** button to make sure that Mix Channels 9 - 16 are off as well.
4. Next, we will assign a different Program to each Mix Channel and adjust the performance parameters. Press the **1/9** button to select Mix Channel 1. Press soft button **6** to enter the **PROG** page:
 - a. Use the **PROGRAM GROUP** and **PROGRAM NUMBER** buttons to assign a Program to this Mix Channel.
 - b. Use soft knob 1 to set the Mix Channel's output level and soft knob **2** to set its panning position. For our purposes in this example, set **PAN** to **-100** (all the way left).
 - c. Use soft knob **3** to set the **OUTPUT** to **MAIN**. Mix Channels normally default to **MAIN**, so just make sure that **MAIN** is selected. Settings for **SEMI**, **CENTS**, and **MIDI CH** are optional for this example.
 - d. Press soft button **5** to display the **KBD** page. Make sure that **KBD LO** is set to **C-1** and **KBD HI** is set to **G9**. These are the default settings for a Mix Channel's keyboard range which spans the entire MIDI note range of 0 - 127. Last, make sure that **ENABLE** is set to **-ON-**.
 - e. Settings on the **CNTL** page for **MIDI IN** and **MIDI OUT** are optional for this example.
5. Press the **2/10** button to select Mix Channel 2 and soft button **6** to re-enter the **PROG** page. Follow sub-steps a. through e. above in setting up Mix Channel 2 with the exception of step b. where you want to set the panning to **+100** instead of **-100**. By panning Mix Channel 1 hard left and Mix Channel 2 hard right, it's easier to hear the layer.
6. Play the A6's keyboard. For every key you play, you should hear two Programs at the same time. Note that the A6's 16 voices are divided between the two Mix Channels. Each Mix Channel plays eight voices.

SPLITS

The major difference between a split and a layer is in the `KBD LO` and `KBD HI` settings define the limits of the keyboard range or “zone” of the Mix Channel. In a layer, the settings **overlap**; but in a split, the settings **separate** (“split”) the keyboard.

TO SPLIT THE KEYBOARD IN MIX MODE:

Start from the Mix we setup in layers on the previous page.

1. Press **MIX SELECT** button **1/9** to select Mix Channel 1.
2. Press soft button **5 (KBD)** and use soft knob **2** to set Mix Channel 1’s `KBD HI` note down to `B3`, the B below Middle C. This effectively makes Mix Channel 1 the “lower” or left-hand keyboard zone.
3. Next, we’ll set up Mix Channel 2 to be the “upper” or right-hand keyboard zone. Press **MIX SELECT** button **2/10**, and use soft knob **1** to set Mix Channel 2’s `KBD LO` note up to `C4`, Middle C.

The A6’s keyboard is now “split” between Middle C and the B below it with Mix Channel 1 playing notes up to and including the B key and Mix Channel 2 playing all notes from Middle C and above.

Tip: To set the Hi and Lo values using the keyboard instead of the knobs, turn soft knob **3 (USEKBD)** to set this feature to **-ON-**. When either `KBD LO` or `KBD HI` is highlighted (by turning their soft knobs or by pressing soft button **5 (KBD)**), play any note on the keyboard to set the value. Make sure to turn this off to avoid inadvertently changing split points.

Another neat trick: To get a “hole in the middle”, so one mix channel will play at the low end and high end of the keyboard but NOT in the middle, simply set `KBD LO` so it’s **higher** than `KBD HI`. The channel will play all notes except between those two points, creating a “hole” where no notes play for that Mix Channel, while notes on either side will play (up and down to the limits of the MIDI note range). So a Mix Channel with a `KBD LO` limit of `C6` and a `KBD HI` limit of `C5` would be playable from the range of `C-1` to `C5` (inclusive) and from `C6` to `G9`.

BEYOND SPLITS AND LAYERS

As you can see by our previous examples of creating a split or a layer, this is only the beginning. The key point here is that we used only two Mix Channels. What happens when we use three? Or more? By activating a third Mix Channel with a layer, a three-level layer is created. Activating a fourth Mix Channel adds a fourth layer.

Just keep in mind that each new Mix Channel, if `ENABLE` is **-ON-** in the `KBD` page, divides the available 16 voices among the active Mix Channels. $16 \text{ voices} \div 4 \text{ Mix Channels} = 4 \text{ voices per Mix Channel}$. But if `ENABLE` is **-OFF-** in the `KBD` page, the Mix Channel can be used to play a MIDI instrument from the A6’s keyboard and doesn’t take A6 voices away from the other active Mix Channels.

For splits, adding another Mix Channel and resetting `KBD LO` and `KBD HI` zone limits for each Mix Channel **to avoid overlap** creates a three-way split. Add another Mix Channel for a four-way split and so on. If the `KBD LO` and `KBD HI` zone limits for two Mix Channels **do overlap**, the result is a split keyboard with a layer.

| PAGE | PARAMETER | OPTIONS or RANGE | DESCRIPTION |
|--------------------|-----------|---------------------|--|
| KEYED continued | TXMODE | | Sets the control output of the A6 keyboard: |
| | | LOCMID | The keyboard will play the A6's voices and transmit MIDI Notes. |
| | | MIDI | The keyboard will transmit MIDI Notes only – the A6's voices will not be played by its keyboard. This setting is the same as "Local Off" on other instruments. |
| | | LOCAL | The keyboard will play the A6's voices only – the A6 will not transmit MIDI Notes played on its keyboard. This setting is the same as "MIDI Off" on other instruments. |
| | MIDICH | 1 ... 16 | When the keyboard MODE is set to MIDI ONLY, this parameter sets the MIDI Channel that the keyboard will use to transmit. This parameter is only displayed when MODE is set to MIDI ONLY. |
| | AFTCH | 0 - 100 | Adjusts keyboard aftertouch sensitivity. A setting of 0 makes the keyboard less sensitive to aftertouch. A setting of 100 makes the keyboard more sensitive to aftertouch. |
| | VSTEAL | ON, OFF | Sets whether voice stealing will take place. Voice stealing usually occurs when the polyphony of the instrument (in this case, sixteen voices) has been exceeded and an old voice has to be "stolen" (silenced) in order to play a new one. If voice stealing is turned off, no new notes will sound after the polyphony has been exceeded. The default setting is "on". |

PEDAL Page Parameters

Use the parameters on this page when setting up your pedals that are plugged into the A6's rear panel. You can refer to page 68 for the physical and electrical specifications of the types of pedals that are compatible with the A6.

| PAGE | PARAMETER | OPTIONS or RANGE | DESCRIPTION |
|-------|-----------|---------------------|---|
| PEDAL | PEDMOD | | These settings affect PEDAL/CV input on the A6's rear panel. |
| | | CC | Use this setting if the pedal plugged into the PEDAL/CV jack is a continuous pedal. |
| | | CC REV | This setting causes a continuous pedal to act in reverse: pushing the pedal forward causes less instead of more. |
| | | SW | Use this setting if the pedal plugged into the PEDAL/CV jack is a footswitch ("on-off" type). |
| | | SW REV | This setting causes a footswitch to act in reverse: stepping on the pedal is off rather than on. This also means that the footswitch is always on until you step on it. Be careful. |
| | FSWMOD | | Identical to PEDMOD except that the settings affect the SWITCH input on the A6's rear panel. |

MIDI Page Parameters

This page controls how the Andromeda responds to incoming MIDI messages such as Program Change commands, and whether it will transmit MIDI Continuous Controller messages. For details on setting these parameters, see **Chapter 12: MIDI**.

CC MAP Page Parameters

This page assigns particular MIDI Continuous Controller numbers to the Andromeda's footswitches and ribbon. It also sets the MIDI CC numbers that will be used for the Modulation sources MIDI CC A-H. For details on setting these parameters, see **Chapter 12: MIDI**.

PANEL Page Parameters

This page sets how the panel controls respond, and whether they send and receive MIDI NRPN data. For details on setting these parameters, see **Chapter 12: MIDI**.

VOXMON Page

This page has no soft knob or soft button control. Designed for advanced users, it is a *voice activity monitor*, showing which of the Andromeda's 16 voices are currently in use. In addition to its usefulness as a tool to identify which voices are being used by which Mix Channels (for example), it allows users to see how a mix might be (unexpectedly) using polyphony, e.g. if an **ENV3** release is too long.

Another voice activity monitor is displayed on the main Program and Mix display. A series of dashes will appear above the BANK and NUMBER legends showing which voices are being used as you play.

MASTER CONTROLS

VOLUME

The **MASTER VOLUME** knob is a *global* (affects the A6 in all modes) volume control that determines the final output level of the unit. To use an audio term, **MASTER VOLUME** is *post* (comes after) the **PRE** and **POST FILTER** mixes and the **VOICE MIX**. This means that any **relative** level settings you make within the Programs and Mixes are preserved. The **MASTER VOLUME** is routed to the unit's **MAIN LEFT** and **RIGHT** stereo outs, the **HEADPHONE** output and the two **AUX OUTS**. It does not affect the eight stereo **VOICE OUTPUTS**.

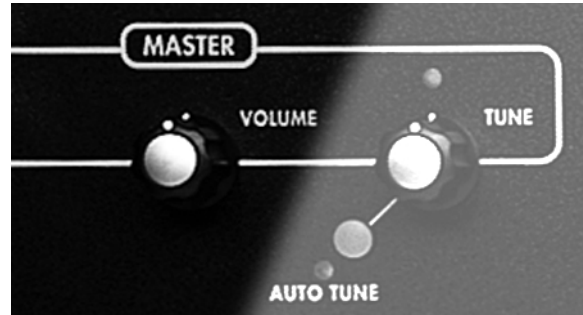

You operate this control by simply turning it: fully counter-clockwise shuts the audio outputs off, fully clockwise is maximum.

TUNE

MASTER TUNE is also global and is used to tune the A6 to another instrument or tuning device. This control is *post* (or "after") the frequency of the VCOs and Filters, Transpose and Detune. So any **relative** frequency settings you make within the Programs and Mixes, or global pitch changes such transpose or pitch bend, are preserved.

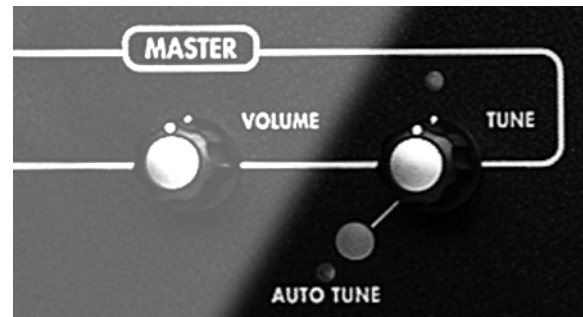

You operate this control by turning it to the left or right of **center**. Setting this knob near the 12 o'clock center position tunes the A6 to standard pitch. You will know that the knob is at 0 when the associated LED lights. Turning the knob to the left causes the A6 to tune flat; turning the knob to the right causes it to tune sharp.

Adjusting this control displays the global **TUNE** page where more precise and custom control over the global tuning can be made. When displayed, the global **TUNE** page shows the precise tuning frequency in hundredths of Hz. In addition to using the **MASTER TUNE** knob to adjust tuning, you can also use soft knob 1 when global **TUNE** is displayed as well as the ▲ and ▼ buttons. And remember, when the **MASTER TUNE** parameter is selected in global **TUNE**, pressing both arrows together resets **MASTER TUNE** to precisely 440.00.

Also included on the global **TUNE** page is the **BKTUNE** or "background tuning" option. Use soft knob 2 to turn it on or off. After you perform an **AUTO TUNE** (next topic), background tuning will continuously monitor the VCOs and make adjustments as they are needed. (The VCFs are not tuned in the background.)

AUTO TUNE Button

Pressing **AUTO TUNE** displays the auto tune page. Pressing it again initiates a routine that fine tunes or *calibrates* a number of A6 functions to an internal tuning reference.

Tip: You need to auto-tune the A6 after you first turn it on and should do it again after it warms up (about 15 minutes). After that, background tuning (if turned on) will keep your A6 in tune as long as it is powered on.

During the Auto Tune process both VCO's frequencies and pulse widths, and both VCF's frequencies and resonances are calibrated along with a number of other parameters. If you want to tune only one type of module (only oscillators, or only filters), you may select that using the soft buttons.

While Auto Tune is in process, the display shows a progress/status box and the LED next the button blinks. At all other times the Auto Tune LED is off.

For more detail on Auto Tune, see **Troubleshooting** on page 265.

THE KEYBOARD AND KEYBOARD MODES

This might be a big assumption, but we get the impression that some players may be interested in learning about the keyboard since the A6 is a keyboard instrument. All joking aside, the A6's keyboard makes the unit a particularly versatile instrument, especially when you take into consideration the varied performance modes plus the addition of portamento.

KEYBOARD SPECS

The A6's keyboard is a 5-octave C-to-C *semi-weighted* keyboard. This means that it has a similar design to an organ as opposed to a piano, which has heavier keys due to its mechanical hammer action. But small weights under each key provide mass so the action is a little heavier than typical synthesizers.

Properties

The A6's keyboard is sensitive to *Velocity* (how hard the keys are struck) and *Release Velocity* (how fast the keys are let go). Velocity and Release Velocity information from the keyboard is sent to the A6's internal Voices and to **MIDI OUT** so that receiving instruments connected to the A6 can respond to these performance dynamics.

The A6's keyboard also responds to *monophonic pressure* – known in the MIDI world as Channel Pressure or Aftertouch – which means that if you play a chord and press into the keys, the A6 **averages** the amount of pressure you're applying and sends that information to the Voices and **MIDI OUT**.

There is another kind of key pressure called *polyphonic key pressure* which reads the amount of pressure on each key and sends the **individual amounts** to the Voices and **MIDI OUT**. Although the A6's keyboard does not respond to this type of pressure, the A6's Voices **will** respond to poly pressure received from another MIDI device capable of transmitting this type of pressure.

Note Range

Although the range of the keyboard is limited to 61 physical keys, the entire MIDI Note Range of 128 notes (numbered 0 to 127) are available. Each key of the A6's keyboard as well as any received MIDI Note is given a number. This number is used by the A6 to determine what musical note or notes to play.

Assuming that the Transpose function (see below) is not being used, Middle C is "Note Number 60" as far as the A6 is concerned. With that in mind, you can easily find the Note Number of any key just by adding or subtracting the number of keys up or down from Middle C.

Using the **TRANPOSE** function, the range of the keyboard can be shifted up or down using Middle C on the A6 as your reference. See page 58.

PERFORMANCE FEATURES

KBD MODE Controls

The **KBD MODE** (“keyboard mode”) functions allow for quick and easy access to three of the most common performance characteristics of the keyboard: **UNISON X** which provides several unison playing modes, **DETUNE** which allows you to set an amount of detuning among the voices when in unison, and switching between **POLY** and **MONO** playing.

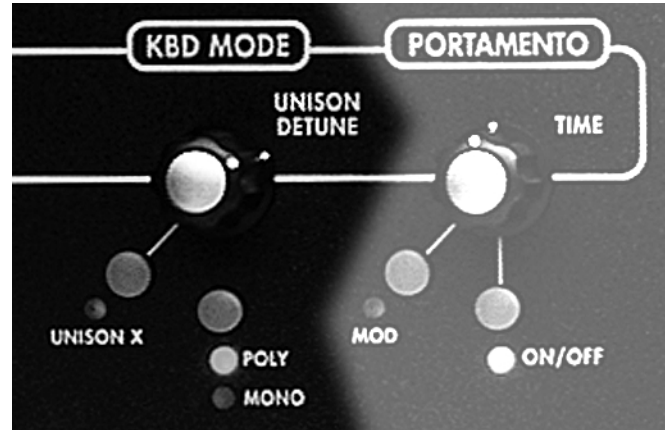

UNISON X Button

In the classic sense of the word, unison is a performance mode which slaves all voices to one key or one received MIDI Note. In the A6, unison is a **set** of keyboard modes in which “all-voices-play-with-one-key” is just one of the options.

Pressing this button enables the **UNSN-X** parameter on the **KBMODE** page, and lights the **UNISON X** LED. This parameter allows you to select the number of voices that will play with one key or one MIDI In note. Minimum is two voices, maximum is 16. In **STACK** mode, the maximum number of voices are played, automatically allocated to maintain polyphony. For example, if you play 1 note, all 16 voices will stack on it; if you play 4 notes, each note will be a stack of 4 voices.

DETUNE Knob

Turning this knob also displays the **KBMODE** screen, selecting the **DETUNE** parameter on the **KBMODE** page. This parameter allows you to adjust the unison **DETUNE** parameter. Turning this control clockwise adds detune amounts to voices playing in unison.

POLY/MONO Button

Pressing this button toggles the Keyboard Mode between **POLY** (polyphonic) or **MONO** (monophonic) type. Pressing this button also initiates the **KBMODE** screen, selecting the **POLY** parameter on the **KBMODE** page to show which Keyboard Mode is currently active. This parameter interacts with the **UNISON X** mode, permitting a polyphonic version of unison.

Keyboard Mode Parameters

Pressing the **UNISON X**, **POLY** or **MONO** buttons, or turning the **DETUNE** knob will display the **KEMODE** page. Note that the display shows **PROG MODE** or **MIX MODE** (depending on the mode selected). Separate keyboard settings are available for each mode.

| SOFT KNOB → | 1 | 2 | 3 | 4 | 5 | 6 | 7 | 8 |
|-------------|--------|--------|------|------|----------------|--------|---|---|
| ↓ PAGE TAB | | | | | | | | |
| KEMODE | DETUNE | UNSN-X | POLY | MONO | MIX or | ASSIGN | | |
| | | | | | MIX | | | |
| | | | | | *Mix mode only | | | |

KEMODE Page Parameters

| PAGE | PARAMETER | OPTIONS or RANGE | DESCRIPTION |
|---------------|---------------|------------------------------|--|
| KEMODE | DETUNE | 0 ... 100 | Only effective if UNSN-X mode is active. |
| Keyboard Mode | Unison Detune | ± cents | This parameter controls the “width” of the voice tuning in Unison mode: the pitch of each voice will be staggered up and down towards the selected tuning offset.* Being able to detune voices in unison mode provides a very “fat” and rich unison sound. |
| | UNSN-X | - OFF - STACK 2 ... 16 | Sets the number of voices that will be played by one note from a minimum of 2 to a maximum of 16, or off. If it is set to STACK, all available voices will be stacked up automatically on the keys being played. |
| | POLY | POLY | The keyboard/MIDI In plays voices polyphonically. One voice is used for each note played (or received). If UNSN-X is on, the number of voices used per note is determined by the setting of the Unison-X parameter. |
| | | MONO | This setting allows only one note to sound , even you’re playing a chord. Each new note that is played/received while the note is held will simply change the pitch of the playing voice. The characteristics of MONO mode are determined by the MIXMUX and ASSIGN parameters described next. |

*See **About DETUNE** on the next page.

| PAGE | PARAMETER | OPTIONS or RANGE | DESCRIPTION |
|---------------------|----------------------|---------------------|---|
| KBMODE Continued | MONOXX Mono Voice | 1 ... 16 ± cents | Only available if MONO mode is selected in the POLY parameter, MONOXX selects a specific voice to be played. This effectively turns the A6 into a 2-oscillator, single-voiced instrument. This feature is useful when the individual VOICE OUTPUTS on the back panel are used. If you need to isolate voice 8, for example, set this parameter to 8. |
| | ASSIGN | | This parameter selects which voices of the A6 will be assigned to incoming notes. |
| | | LOWEST | This will always play the lowest available voices. |
| | | ROTARY | This assigns new notes to the 16 voices so that all voices are used in turn. |

About DETUNE

As an example of how voices are staggered-tuned, we'll use the extreme setting of 100 which gives the greatest width or amount of detune among the voices.

Mode: maximum UNSN-X set to 16 (16 voices are used for one note)

If DETUNE is set to 100 (100 cents, which is equal to a semitone), the following formula is used to calculate the "spread":

$$\begin{aligned}
 \text{Spread} &= \text{DETUNE setting} / (\# \text{ of voices} - 1) \\
 &= 100 / (16 - 1) \\
 &= 100 / 15 \\
 &= 6.67
 \end{aligned}$$

| | | |
|----------|---------|----------------|
| Voice 1 | pitch = | no change |
| Voice 2 | pitch = | + 06.67 cents |
| Voice 3 | pitch = | - 13.33 cents |
| Voice 4 | pitch = | + 20.00 cents |
| Voice 5 | pitch = | - 26.67 cents |
| Voice 6 | pitch = | + 33.33 cents |
| Voice 7 | pitch = | - 40.00 cents |
| Voice 8 | pitch = | + 46.67 cents |
| Voice 9 | pitch = | - 53.33 cents |
| Voice 10 | pitch = | + 60.00 cents |
| Voice 11 | pitch = | - 66.67 cents |
| Voice 12 | pitch = | + 73.33 cents |
| Voice 13 | pitch = | - 80.00 cents |
| Voice 14 | pitch = | + 86.67 cents |
| Voice 15 | pitch = | - 93.33 cents |
| Voice 16 | pitch = | + 100.00 cents |

Additional Keyboard Functions

TRANPOSE Button

The **TRANPOSE** button allows you to play the A6 in a different key. This is a global setting that affects all Programs and Mixes and remains in effect until it's changed, even if the A6 is powered off.

To set the transpose amount, hold down the **TRANPOSE** button, then press a key. The A6's keyboard will be transposed by that key's distance from middle C.

Alternatively, you can press the **TRANPOSE** button, then adjust the transpose amount using soft knob 1.

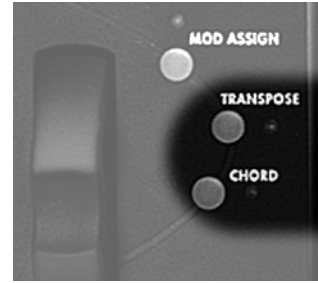

CHORD

The **CHORD** button allows you to play a chord with a single key. To define a chord, hold down the **CHORD** button until the chord LED starts to blink. Then, play the notes of the chord and release the button.

After the chord is in memory, playing a single note on the keyboard will play the chord relative to the note you played. To toggle chord mode on and off, simply press the **CHORD** button.

All of the notes of the chord will be sent out MIDI. The notes of the chord are stored in global memory, so they will stay the same even after you change programs or mixes.

PORTAMENTO

A Italian term (from a Latin root) that means *sliding*, portamento causes the A6's Voices to "slide" (sometimes called "glide") to the notes being played. When you are playing the A6 normally, played keys or MIDI Note On messages activate the Voices with the appropriate notes **instantly**. With portamento active, it takes a period of time – set by the **TIME** knob – for the Voices to reach the played notes by "sliding into them".

The first important concept to understand here is that the sliding **direction** is determined by the notes that were previously played. For example, if you play keys in the lowest octave, turn **PORTA** on and then play keys in the upper range of the keyboard, the Voices will slide up to the higher notes. If you then play lower notes, the Voices will slide down to the new lower keys being played.

The second concept to understand is the **distance** between played notes. Musically speaking, we're referring to the **interval** between successive notes. In contrast to the above example, if you play notes in a certain octave then continue to play in that key range, there's a good chance that portamento may not be that distinct since the distance (interval) between the old notes and new notes is not that great.

The third concept to understand when using portamento is that it is the **voices** that are doing the sliding, not the keys. **The A6 keeps track of all notes played and which voices played them** so that it knows the most current note values of each of its 16 voices. Therefore, depending on what voices were played before portamento is turned on, you may get sliding from all directions or not much at all. The distance and direction of the glide depends on which voice is getting the new note **relative** to what note this voice played before.

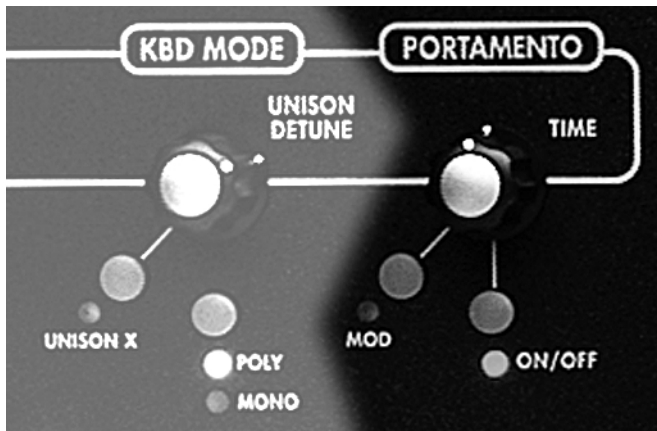

PORTAMENTO CONTROLS

Portamento is fully programmable per Program.

TIME Knob

This control varies the portamento rate, or the amount of time it takes to slide from previously played notes to the target notes. Portamento time is adjusted in either seconds or seconds-per-octave depending on the selected portamento mode. Turning this knob selects the **TIME** parameter on the **PORTA** page.

MOD Button

Pressing the **MOD** button displays the **MOD** page of modulation parameters for portamento. This page provides parameters for creating a mod route to the portamento's **TIME** parameter (displayed on the **MOD** page as **PORTA RATE**), providing variations in the portamento speed. If a mod route has been created by turning the **ENABLE** parameter to **ON**, the **MOD** LED will be illuminated. Using a modulation on **TIME**, you can affect the rate of sliding in countless ways.

ON/OFF Button

This button simply turns the portamento function on or off. When on, the LED will light. Pressing this button selects the `ENABLE` parameter on the `PORTA` page.

Portamento Parameters

| SOFT KNOB → | 1 | 2 | 3 | 4 | 5 | 6 | 7 | 8 |
|-------------|--------|--------|-------|--------|--------|--------|--------|---|
| ↓ PAGE TAB | | | | | | | | |
| PORTA | TIME | SPEED | MODE | CURVE | ENABLE | OSC EN | FLT EN | |
| STMODE | MODE | OFFSET | | | | | | |
| MOD | SOURCE | | LEVEL | OFFSET | ENABLE | | | |

PORTA Parameters

| PAGE | PARAMETER | OPTIONS or RANGE | DESCRIPTION |
|-------|-----------|--------------------------|--|
| PORTA | TIME | OFF 2 M... 32.77 S | Sets the speed of the glide between notes. Minimum is 2M or 2 milliseconds; maximum is about 33 seconds. Longer portamento times may be achieved by modulating the time through a mod route. |
| | SPEED | OCTAVE 1SPEED | This parameter determines the method used to calculate the rate of portamento between notes: When set to <code>OCTAVE</code> , the <code>TIME</code> setting is determined by the interval between notes and is expressed in “seconds per octave.” If <code>TIME</code> is set to 5.00 seconds, for example, the time it takes to slide one octave is 5 seconds. The time it takes to glide the entire length of the keyboard (five octaves) is 25 seconds. When set to <code>1SPEED</code> , the <code>TIME</code> setting doesn’t care about the interval in its calculations. The rate of sliding is the same between semitones as it is between octaves. Using the previous example of 5.00 seconds, it takes five seconds to glide from the E key to the F key just above it, just one semitone. It also takes five seconds to slide from the same E key to the E three octaves above it. |

| PAGE | PARAMETER | OPTIONS or RANGE | DESCRIPTION |
|--------------------|-----------|---------------------|--|
| PORTA Continued | MODE | | This parameter is used to select from among three portamento actions: |
| | | NORMAL | Each new voice that is played will have Portamento. The portamento will glide from the last note played by this voice to the new note. |
| | | LEGATO | Voices played <i>staccato</i> will not glide. While holding the first voice of a program, subsequent voices will glide, starting from the last key pressed. |
| | | LEGATO2 | Operates like NORMAL for each first voice of a program. While holding the original note (voice), subsequent notes will not glide. |
| | CURVE | | This parameter allows you to select the slope used to glide between notes. Refer to the discussion and the graphs on the following pages for a complete description of these slopes. |
| | | LINEAR | standard linear slope |
| | | EXP 1 | <i>Exponential 1</i> : less steep version of Exponential 2 |
| | | EXP 2 | <i>Exponential 2</i> : standard <i>ln</i> curve |
| | | EXP 3 | <i>Exponential 3</i> : steeper version of Exponential 2 |
| | | LOG 1 | <i>Logarithmic 1</i> : less steep version of Logarithmic 2 |
| | | LOG 2 | <i>Logarithmic 2</i> : standard e^x curve |
| | | LOG 3 | <i>Logarithmic 3</i> : steeper version of Logarithmic 2 |
| | | SCURV1 | <i>S-Curve 1</i> : forward "S-Curve", created by merging EXP02 into LOG2 |
| | | SCURV2 | <i>S-Curve 2</i> : reverse progression of SCURVE1 |
| | ENABLE | OFF, ON | Enables portamento. The ON/OFF LED reflects the status. |

CURVE: Selecting the Portamento's Slope

Identical to the stages of an envelope, Portamento has a user-selectable property called *slope*. This term refers to how gliding notes *accelerate* (speed up) or *decelerate* (slow down) as each voice approaches its target note:

- A **LINEAR** slope means that gliding notes do **not** accelerate (or decelerate) as they progress towards their target (destination) notes. In the illustration on the next page, notice that the linear slope is depicted as a straight line (from where we get the term “linear”). The glide doesn’t speed up or slow down but keeps an even rate of change.
- An **EXP** (exponential) slope, however, **accelerates** towards the target notes: it starts out slow then speeds up as it gets closer to its destination. Rather than a straight line, it is represented by a curve. One of three exponential curves can be selected.
- In contrast, the **LOG** (logarithmic) slope **decelerates** towards the target notes: it starts out fast then slows down as it reaches its destination. It is represented by a curve that is the opposite of the exponent. One of three logarithmic curves can be selected.
- The **SCURV** (“S” Curve) **combines the slopes** of **EXP 2** and **LOG 2**. One of two S-Curves can be selected:

SCURV1: The rising-amplitude of S-Curve 1 is characterized by acceleration during the first half of its stage using **EXP 2**, then decelerates during the last half using **LOG 2**. This is commonly known as a *forward progression* s-curve.

The falling-amplitude of S-Curve 1 is the opposite of its rising-amp: the stage decelerates during the first half using **LOG 2**, then accelerates during the last half using **EXP 2**.

SCURV2: The opposite of S-Curve 1 – commonly referred to as a *reverse progression* s-curve – the rising-amplitude of S-Curve 2 decelerates during the first half using **LOG 2**, then accelerates during the last half using **EXP 2**.

The falling-amplitude of S-Curve 2 accelerates during the first half using **EXP 2**, then decelerates during the last half using **LOG 2**.

PORTAMENTO SLOPES

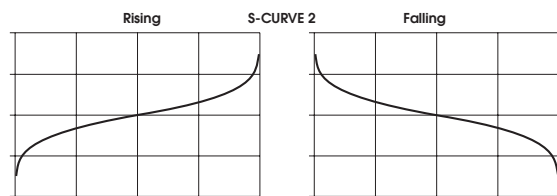
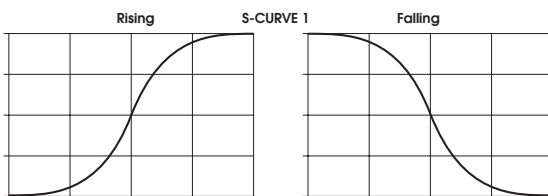
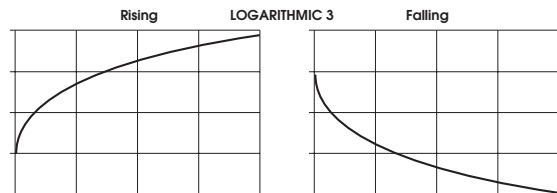
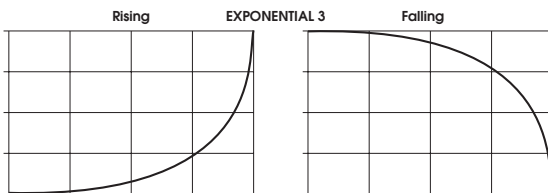
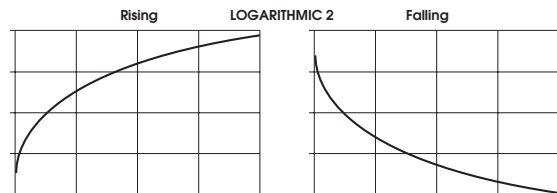
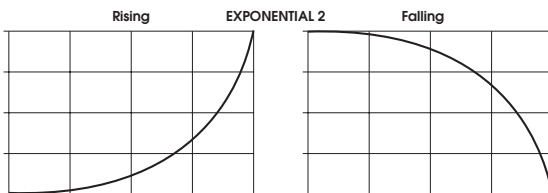
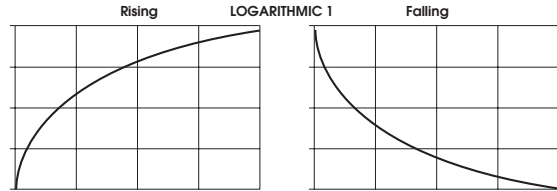
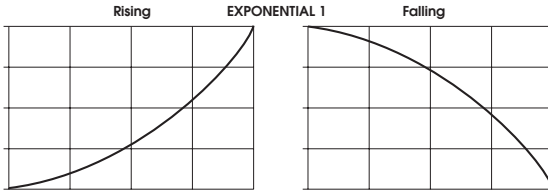
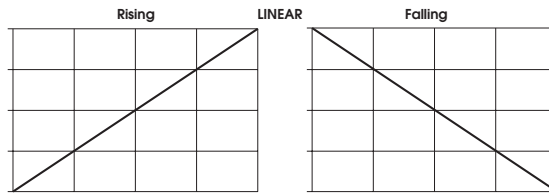

STMODE Parameters

| PAGE | PARAMETER | OPTIONS or RANGE | DESCRIPTION |
|----------------------|-----------|--|--|
| STMODE Start Mode | MODE | | This page determines where the portamento is sliding from—its start point. |
| | | LSTKEY | When a new note is played, it will “slide” from the last key played. |
| | | OFFSET | When a new note is played, it will slide from a fixed number of semitones above or below the note, as set by the OFFSET variable set by Soft Knob 2. |
| | | CHORD | Each voice slides from its previous value. For example, whatever note Voice 8 last played, that’s where it will slide from when called upon again. The voice order is set in the KBD MODE section (Unison X, Poly, and Mono). |
| | OLDEST | Each voice slides from the oldest note that is being held. | |
| | OFFSET | -127 ... +127 | Sets the number of notes above or below the present note where the slide will start, when the MODE is set to OFFSET. For example, a setting of -12 will always start sliding from an octave below the note played. |

Portamento MOD Parameters

The Portamento Modulation parameters permit you to create a mod route to modulate the TIME parameter. Please note that, unlike most of the other MOD pages, TIME is the only Portamento parameter that can be modulated.

| PAGE | PARAMETER | OPTIONS or RANGE | DESCRIPTION | |
|---|-----------|------------------------------|--|---|
| MOD Portamento Time Modulation | SOURCE | NONE or any mod source | Selects one of the A6’s mod sources to modulate the Portamento’s TIME. The default is OFFSET ONLY. | |
| | | LEVEL | -100 ... 100 | Sets the level or intensity of the mod source. |
| | | OFFSET | -100 ... +100 | Standard mod route offset. |
| | | ENABLE | OFF, ON | Turns the modulation OFF or ON. The status of the parameter is also shown by the LED next to the MOD button. |

THE PERFORMANCE WHEELS AND RIBBON CONTROLLER

BACKGROUND

The A6 utilizes two performance wheels that are used mainly for pitch bend (**PITCH**) and vibrato (**MOD**). The Pitch wheel on the left is a spring-loaded wheel that snaps back to its center or neutral position when released, and is normally used for pitch bend. The Mod wheel on the right is not spring loaded and must be manually returned to its off position. It is normally used for vibrato.

But note that you can assign each one to a different destination – you are not confined to using them for strictly pitch bend and vibrato. In fact, you can make both pitch bend or both vibrato, if you so desire.

Better yet, they can be **neither** pitch bend nor vibrato, as you can assign these wheels to modulate any parameter of the sound that is designated as a mod destination. But best of all, you can assign the wheels **to perform multiple modulations at the same time**. Imagine a wheel causing vibrato, increasing the reverb amount, fading in the sub-oscillators and triggering the sequencer all at once. See **Chapter 9: Custom Modulations** for an in-depth look at Andromeda’s “modulation matrix” that allows you to customize *mod routes* or *mod paths* to achieve out-of-the-ordinary results.

In any case, the purpose and range of these wheels are **programmable per Program**, which makes them incredibly flexible. Consider the possibility of a wheel being used to control the brightness of the sound instead of pitch, or to control the amount of reverb or chorus, or to alter the pulse width of one (or both) VCOs... The possibilities are virtually limitless.

Typically, the pitch wheel is set up so that pushing it away from you bends played notes **up** in pitch and pulling bends them **down**. The A6’s pitch wheel however, can have its *polarity* – the positive/negative attributes – **reversed** so that pushing pitch-bends down and pulling bends up.

The pitch wheel can also be programmed so that it can have a different type of modulation on either side of the center stop. You can set the wheel to pitch bend when pushed (up **or** down, your choice) and change the portamento time when pulled, as just one of many, many examples.



You can think of the Ribbon Controller as a wheel that’s been stretched across the A6’s front panel. It can be assigned to any of the A6’s mod destinations and is programmable per Program like the wheels. It operates simply by touching it with a finger and sliding it along the ribbon’s surface.

One of its attributes that distinguishes it from the wheels is that it may be divided in half—the left and right sides (from the center line mark on the top panel) may act as separate controllers aimed at separate destinations. And because the Ribbon Controller has a much longer travel than the wheels, it typically has a more accurate response since you have more physical space across the ribbon’s surface within a given range.

In all cases – for both wheels and the ribbon – the MIDI Controller Number is user-selectable and programmable per Program so you can determine how the wheels will affect other instruments via MIDI for each Program.

PROGRAMMING THE WHEELS AND RIBBON

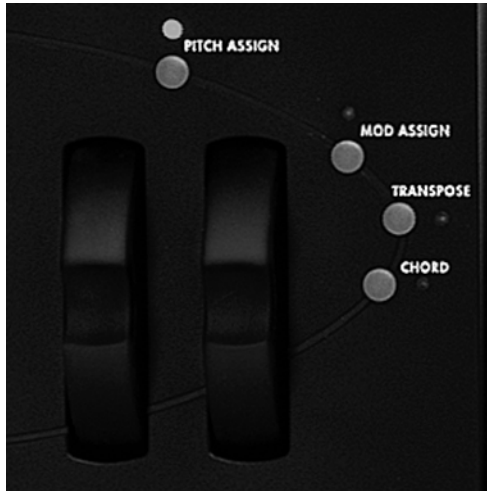

All of the Programs that ship with the A6 have default wheel and ribbon modulations stored with them. In most cases (but not all), the left wheel and ribbon are preset for pitch bend and the right wheel is vibrato. Some factory Programs, on the other hand, have the wheels and ribbon preset to other types of modulation depending on what is appropriate for the Program.

For MIDI purposes, the right wheel defaults to MIDI Controller 1 (vibrato) and the left wheel and ribbon are assigned to Channel Pitch Bend. These assignments can be changed, however, and stored for each Program.

To make changes to either wheel, press the **PITCH** (“Pitch Wheel”) **ASSIGN** or the **MOD** (“Mod Wheel”) **ASSIGN** button. The parameters for that wheel will be displayed. Likewise, pressing the **RIBBON** button to the left of the ribbon controller displays its parameters.

PITCH ASSIGN Parameters

| SOFT KNOB → | 1 | 2 | 3 | 4 | 5 | 6 | 7 | 8 |
|-------------|--------|--------|--------|--------|-------|-------|---|---|
| ↓ PAGE TAB | | | | | | | | |
| PWHEEL | BOTRNG | TOPRNG | BOTCRV | TOPCRV | OSC 1 | OSC 2 | | |
| CROUTE | SOURCE | | LEVEL | ENABLE | ROUTE | | | |

| PAGE | PARAMETER | OPTIONS or RANGE | DESCRIPTION |
|--------|------------------------|----------------------|---|
| PWHEEL | | | The A6 permits you to adjust the range of the upper travel of the Pitch Wheel independent of its lower travel: |
| | BOTRNG Bottom Range | -0 ... 48 | This parameter adjusts the bottom range of the Pitch Wheel from 0 to 48 semitones (4 octaves). The default value is two semitones (one Whole tone). |
| | TOPRNG Top Range | +0 ... 48 | This parameter adjusts the top range of the Pitch Wheel from 0 to 48 semitones. The default value is two semitones (one Whole tone). |
| | BOTCRV Bottom Curve | LINEAR ... SCURV2 | This parameter selects one of nine response curves for the wheel's lower travel. See the discussion on curves starting on page 62. |

| PAGE | PARAMETER | OPTIONS or RANGE | DESCRIPTION |
|-----------|-----------|------------------|--|
| PWHEEL | TOPCRV | LINEAR ... | This parameter selects one of nine response curves for the wheel's upper travel. See the discussion on curves starting on page 62. |
| Continued | Top Curve | SCURV2 | |
| | OSC 1 | OFF, ON | Turn the effect of the Pitch Wheel on OSC 1 on or off. |
| | OSC 2 | OFF, ON | Turn the effect of the Pitch Wheel on OSC 2 on or off. |

MOD ASSIGN Parameters

| SOFT KNOB \rightarrow | 1 | 2 | 3 | 4 | 5 | 6 | 7 | 8 |
|-------------------------|--------|-------|-------|--------|-------|---|---|---|
| \downarrow PAGE TAB | | | | | | | | |
| MODWHL | SCALE | CURVE | | | | | | |
| CROUTE | SOURCE | | LEVEL | ENABLE | ROUTE | | | |

| PAGE | PARAMETER | OPTIONS or RANGE | DESCRIPTION |
|--------|-----------|----------------------|--|
| MODWHL | SCALE | 0 ... 100 | Adjusts the modulation amount from the wheel. Higher values = more modulation. |
| | CURVE | LINEAR ... SCURV2 | This parameter selects one of nine response curves for the wheel's travel. See the discussion on curves starting on page 62. |

CROUTES (Control Routes)

A second press of either the **PITCH ASSIGN** or the **MOD ASSIGN** button will bring up the **CROUTES** page. This allows you to see and change the internal routings of the controllers. By turning the **ROUTE** knob, you can see the source routed to that destination. You'll need to enter this page whenever you want to create custom control setups that are different from the defaults. For more information, see **Chapter 9: Custom Modulations**.

Ribbon HOLD Buttons

On each side of the ribbon there are **HOLD** buttons. When ribbon hold mode is on, the ribbon value will be "sticky". That is, when you lift your finger from the ribbon, it will hold its value. When you exit ribbon hold mode, the ribbon value will snap back to zero.

Pedals and Footswitches

It seems as if anything plugged into an instrument that you step on is called a pedal. Well, not exactly. There are actually **two** types of “foot-actuated controllers” in the context of an electronic instrument. Although it’s politically correct to call them “pedals” generically, one is accurately called a switch, and one is accurately called a pedal. We’ll define both of them:

A foot **switch** is a *momentary* device – it is a spring-loaded switch that operates by “pressing and releasing” for ON (press: foot down) or OFF (release: foot off) signals. The A6 uses footswitches with a 2-conductor 1/4” connector and are plugged into the **SWITCH** and **SUSTAIN** functions of the A6.

A foot **pedal** is a *potentiometer* device – the pedal mechanically operates an internal **knob** (technically known as a potentiometer) giving you “more” or “less” rather than “on” or “off” like a switch. These pedals are often referred to as “rocker pedals”. The A6 uses a footpedal with a 2-conductor 1/4” connector typically used for volume and modulation and is connected to the **PEDAL/CV** jack.

The diagram below shows what the right kind of connector looks like if you want to purchase a pedal or switch.

Soft Pedal, Volume and Modulation Pedal Connector

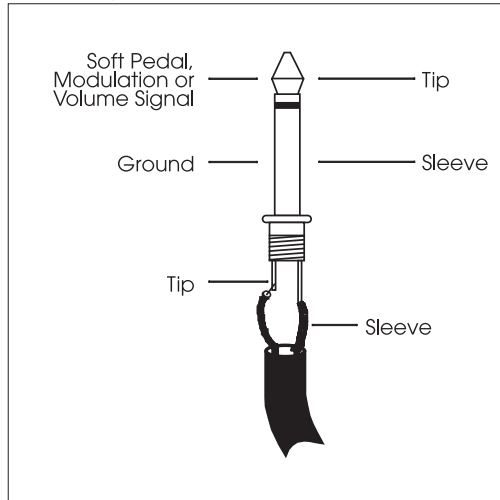

Sustain/Sostenuto Pedal Connector

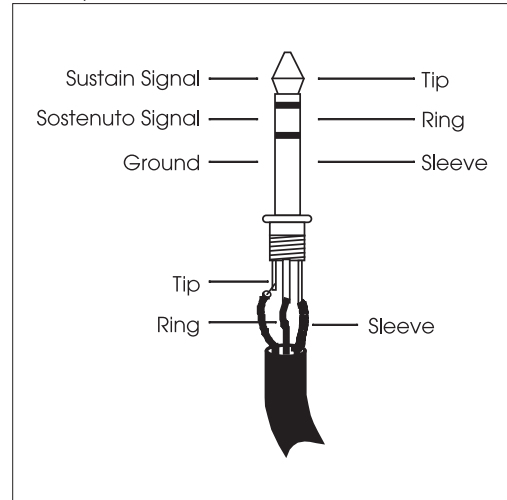

Footswitch and pedal functions are *defined* (set up) in the **PEDAL** page of **GLOBAL** mode. This set of parameters in the A6 are particularly interesting (and useful) as they permit you to reverse a pedal’s action or make its MIDI function different from its local function. For example, a rocker-type pedal that is used as a volume pedal on the A6 can be sending modulation messages out MIDI at the same time. For details on the **PEDAL** parameters, see page 50.

THE CLOCK SECTION

The A6's Clock is a global function that provides global synchronization as a modulation source to all voices in Programs or Mixes. By *global sync* we mean that any A6 function that relies on tempo can get its timing from the Clock. The timing can be steady or variable.

Some examples of A6 functions that rely on tempo are the Sequencer and the Arpeggiator. You can also slave modulation sources such as LFO rates and Envelope stages to the Clock when their timing needs to coincide with a song's tempo. Normally, the A6's LFOs run independently of the Clock as they have their own generators for **RATE**. The same applies to Envelopes whose stages are normally timed by their own circuitry. But when the need arises to synchronize one or more LFOs or Envelope stages to a common tempo, this is accomplished by slaving the desired destination to the Clock.

Conversely, you can modulate the Clock's tempo by an LFO or Envelope or any of the A6's 71 modulation sources. This is accomplished using **SYNC/MOD** as described below.

How the A6's clock is integrated with the Sequencer and Arpeggiator is covered in the following topics. Slaving an LFO to the Clock is covered in Chapter 7. Slaving an Envelope stage is discussed in Chapter 6.

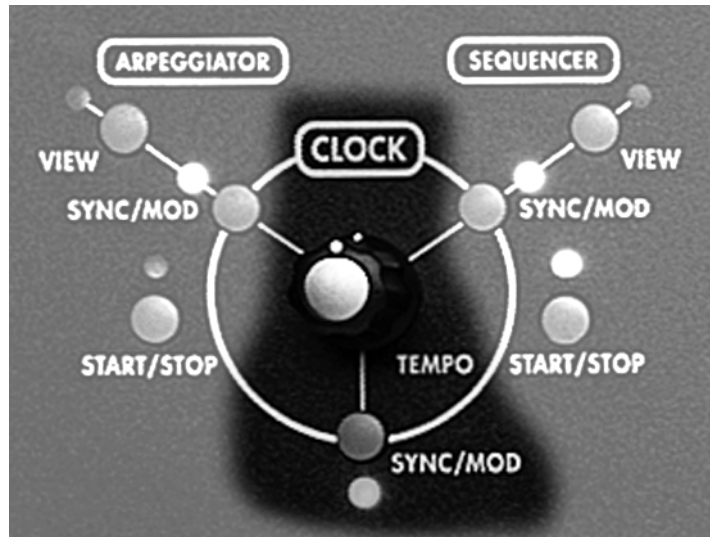

CLOCK PARAMETERS

| DISPLAY PAGE | PANEL LABEL | PARAMETER DISPLAY | OPTIONS or RANGE | DESCRIPTION | |
|--------------|---------------|-------------------|---------------------------|---|--|
| CLOCK | TEMPO Knob | TEMPO | 0.458 ... 500.0000 | The knob adjusts the tempo of the Clock from .46 bpm to 500 bpm. | |
| | | | | Beats Per Minute | |
| | | | START | | This parameter determines how the clock is started. |
| | | | Clock Start Mode | | |
| | | | | NORMAL | The clock will be free-running. |
| | | | | KEYDN | The clock will re-start whenever a non-legato key is pressed, in other words, upon the first key-down. |
| | | | MODUOX | | This parameter is used to select the amount of modulation triggered by a voice . Use the soft knob below this parameter in the display to select one of three options, described below. |
| | | | Tempo Modulation by Voice | | |
| | | | | FIRST | The first voice to modulate the clock will determine the modulation source amount. If this first voice is released while other voices are held, the last modulation source for the first voice is held and used. |
| | | | | OLDEST | The oldest voice playing this sequence will determine the modulation source amount. |
| | | | NEWEST | The newest voice playing this sequence will determine the modulation source amount. | |
| | | MODCHN* | 1 - 16 | In Mix Mode, this parameter determines which Mix Channel will modulate the Clock. | |
| | | Mod Mix Channel | | | |
| | | SYNSRC | | Selects the source from which the Clock's tempo is generated. Note That this is a Global Parameter, so it keeps its value even after changing Programs or Mixes. | |
| | | Sync Source | | | |
| | | | LOCAL | The A6's internal dedicated clock | |
| | | | MIDI | Incoming MIDI clock from an external MIDI Master | |
| | | CLKOUT | OFF, ON | Selects whether MIDI Clock is sent out the MIDI port. This is a Global Parameter, so it keeps its setting even after changing Programs or Mixes. (Note that MIDI Clock is different from MIDI Song Position Pointer). | |

SYNC/MOD Button

Pressing the **SYNC/MOD** button that is located directly below the **TEMPO** knob displays the parameters for modulating the tempo of the Clock by any of the A6's 71 modulation sources. Use **SYNC/MOD** to modulate the tempo of the Clock by the selected mod source.

SYNC/MOD Parameters

If the **SYNC/MOD** button is pressed, the following parameters will be shown on the display. Unlike other MOD pages, there's no **DEST** parameter controlled by Soft Knob 6 because there is only one destination, the **CLOCK RATE**.

| DISPLAY PAGE | PANEL LABEL | PARAMETER DISPLAY | OPTIONS or RANGE | DESCRIPTION |
|---------------------------------|-------------|-------------------|--|--|
| MOD | — | SOURCE | Any of the A6's 71 modulation sources. See Appendix B. | Use soft knob 1 to scroll through the list of possible modulation sources. |
| | — | LEVEL | -100 ... +100 | This parameter sets the amount of modulation that will affect the tempo. Keep in mind that negative values invert the action of the selected source. For example, if Velocity is the source and a negative value for LEVEL is used, playing harder will reduce the level and thus slowing the tempo of the Clcok. |
| | — | OFFSET | -100 ... +100 | This parameter sets the <i>offset</i> or fine adjustment for the selected modulation level. |
| SYNC/MOD Button + LED | | ENABLE | ON, OFF | This parameter is used to turn the selected modulation on or off. Use soft knob 5 or the panel button. |

SEQUENCER

A *sequence* is a series of two or more “events” (usually musical notes) that play one after another – or “in sequence.” The A6 Sequencer is a simple 16-step, 3-level modulation source/note triggering module. It follows the functionality offered by the early analog sequencers found in the Moog and Buchla modular synthesizers, as well as many others.

The Sequencer is a **per Program** function: each of the 128 user Programs can have its own sequence that is saved in memory along with all of its other settings.

Layout

Each of the sequencer’s 16 “steps” or “events” consists of four components or Levels: a Note, the note’s Velocity amount, the note’s duration called Gate time, and whether a note will play or the step will be a rest, called the Type.

It is important to note here that the A6’s Sequencer, unlike many other sequencers that play their recorded notes when you press **START**, can be triggered by numerous sources. By default, the A6’s Sequencer runs when you play a note, and will play the sequence in a key signature using that note as a reference. Likewise, if a **chord** is played, the sequencer will sequence the chord according to its note settings.

Note that the values for the **NOTE** Level can have either a positive value or a negative value. This means that the sequence can play notes **above and below the root note** of the sequence. For example, a sequence is often constructed such that it starts playing when one note is played and held down. That’s the *root note* of the sequence which is normally set to 0, the equivalent of “no transpose.” The **NOTE** setting for any Step can then be “tuned” up or down from the root. This flexibility in allowing note values below the root provides a way to create interesting and useful melodic patterns.

Of course you can play chords, and the sequencer will play the pattern for every note in the chord.

When an event “plays,” Note, Velocity and Gate are output to the sequencer’s assigned destination—most often the voices—simultaneously. The most common use of the Sequencer is to play musical notes, so each event will generate a Note On (plus its associated Velocity), then output a corresponding Note Off when the Gate Time has expired. Of course, if **TYPE** is set to **REST**, the Step will rest (the **NOTE** and **VEL** settings are bypassed) for the amount of time that the **GATE** is set to.

But also note that the Sequencer can be used as a source in a modulation route. In this case, Note, Velocity and Gate are listed in the **MOD SRC LIST** as **SEQ LEVEL A**, **B** and **C** respectively.

The table below shows the Sequencer Graph. The Graph can be thought of as being in any time signature or combination of time signatures. For example, common 4/4 usage would yield four bars of quarter notes with downbeats at Steps 1, 5, 9 and 13. Depending on how you set the **RATE** setting and Gate times to fit into the song, you can also consider a sequence as two bars of 8th notes, one bar of 16th notes, and so forth. And since you can select the number of Steps, five steps of quarter notes can play a bar of 5/4 and ten steps of quarter notes can play two bars in 5/4 with down beats on steps 1 and 6. Six steps of eighth notes can play a bar of 6/8 and 12 steps of eighth notes can play a two bars of 6/8 with down beats on steps 1 and 7.

| STEP (or “EVENT”) → | A | B | C | D | E | F | G | H | I | J | K | L | M | N | O | P |
|----------------------------|----------|----------|----------|----------|----------|----------|----------|----------|----------|----------|----------|----------|----------|----------|----------|----------|
| NOTE | • | • | • | • | • | • | • | • | • | • | • | • | • | • | • | • |
| VEL (Velocity) | • | • | • | • | • | • | • | • | • | • | • | • | • | • | • | • |
| GATE | • | • | • | • | • | • | • | • | • | • | • | • | • | • | • | • |
| TYPE | • | • | • | • | • | • | • | • | • | • | • | • | • | • | • | • |

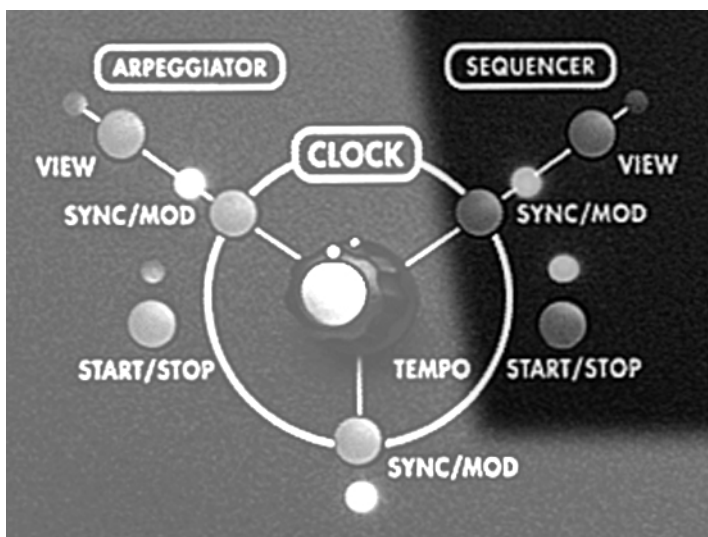

START/STOP Button

Pressing this button enables or disables the Sequencer. This is a programmable parameter that is saved with each Program and with each Mix Channel separately. So, you can have the sequencer enabled for a program in Mix Mode and disabled for that program in Program Mode. **Remember, the sequence will not start until it receives a trigger, normally the keyboard.**

SYNC/MOD Button

Pressing this button displays the Sequencer's MOD page on the screen. The Sync/Mod page of parameters allows you to

modulate the tempo of the sequence. The Sync/Mod parameters table that describes their functions can be found on page 78.

VIEW Button

Pressing this button recalls the page of Sequencer parameters that was last used (it defaults to the GRAPH page). Using this button to enter the Sequencer edit mode allows you to examine the current settings without making any changes. You can, of course, change any setting but you don't have to when using a VIEW button

Sequencer Parameters

This section describes the parameters of the Sequencer. The summary table below shows the Sequencer's parameter names – listed in the rows under under the **SOFT KNOB** numbers – with their associated *page* (parameter group) in the **PAGE TAB** column. The tables on the following pages provide operational details of each display page.

| SOFT KNOB → | 1 | 2 | 3 | 4 | 5 | 6 | 7 | 8 |
|-------------|---|--------|--------|--------|--------|--------|--------|--------|
| ↓ PAGE TAB | | | | | | | | |
| NOTE | A | B | C | D | E | F | G | H |
| VEL | ----- | | | | | | | |
| GATE | I | J | K | L | M | N | O | P |
| TYPE | ----- | | | | | | | |
| CONFIG | LOCBPM | KVTRIG | LENGTH | LPTYPE | LPCNT | MONLEG | ZOOM | USEKBD |
| TRIG | SOURCE | | LEVEL | TYPE | RETRIG | ENABLE | TRGVOX | MODE |
| PROGRS | PRGRSR | MIN | MIX | | | | | |
| SYNC | SYNSRC | STPSIZ | | | | | | |
| MOD | SOURCE | | LEVEL | OFFSET | ENABLE | | | |
| RUN | Pressing this button turns the sequencer on or off. This is the same as pressing the START/STOP button in the SEQUENCER section on the front panel. | | | | | | | |
| 1-16 | Use soft button 8 to select a Step (A – F) on the GRAPH page for editing. | | | | | | | |

GRAPH and 1 - 8 Parameters

The GRAPH page is used to set the Note, Velocity, Gate and Type values for the 16 steps:

- Pressing soft button 1 (GRAPH) repeatedly cycles through the NOTE, VEL, GATE and TYPE parameters for the selected Step.
- Soft knobs 1 through 8 are used to select **and** adjust the values in each Step.
- The graph on top shows the settings for all Steps at once. The Parameter and Value rows of the display show the settings for eight Steps at a time (Steps A - H or Steps I - P). Repeatedly press soft button 8 to tab between the two groups of Steps.

| PAGE | PARAMETER | OPTIONS or RANGE | DESCRIPTION |
|-------|-----------------|----------------------------|---|
| GRAPH | NOTE | E-11 ... G+10 Semitones | This parameter sets the note value of the Step. A setting of C0 indicates that the sequencer will play the note being played on the A6's keyboard or the incoming MIDI Note. |
| | VEL Velocity | 0 ... 127 | This parameter sets the velocity amount of the note set in the NOTE parameter, above. 64 is the default setting. |
| | GATE | 0 ... 100 | This parameter sets the gate time or duration of the note set in the NOTE parameter, above. |
| | TYPE | NOTE, REST | This parameter selects the type of Step, whether it plays a note or a rest. If NOTE is selected, the Step outputs the note set in the NOTE parameter along with its associated VEL and GATE settings. If REST is selected, the Step outputs the GATE time only, effectively playing a musical rest. |

Sequencer CONFIG Parameters

| PAGE | PARAMETER | OPTIONS or RANGE | DESCRIPTION |
|--------------------------------------|------------------------|---------------------|---|
| CONFIG Sequencer Configuration | LOCBPM | 0.46 ... 600.00 | The tempo of the Sequencer displayed in beats per minute. When LOCAL is selected on the SYNC page, the sequencer will use this value for the tempo. If CLOCK or MIDI is selected on the SYNC page, this parameter has no effect. |
| | KYTRIG | OFF, ON | When ON, the sequencer will play a the A6's voice(s) when a note or chord is played. This is the most common usage of the sequencer. The NOTE, VEL and GATE values are also available as mod sources. When OFF, the sequencer will not play a the A6's voice(s) when a note or chord is played. The A6 behaves as if the sequencer isn't running, but NOTE, VEL and GATE values are still available as mod sources. |
| | LENGTH | 1 ... 16 | Selects the number of Steps that the sequencer will play from 1 to 16 (Steps A through P). |
| | LPTYPE Loop Type | | This parameter determines how the sequence "loops" or cycles. |
| | | FORWRD | The sequence plays forward through the selected Steps. |
| | | REVERSE | The sequencer cycles backward through the selected Steps. |
| | | ROKROL | <i>Rock-n-Roll</i> : The sequence cycles backward and forward through the Steps. |
| | LPCNT Loop Count | | When the sequencer is running, this parameter determines the number of times the sequence will loop through the Steps, or turns it OFF: |
| | | 1 ... 240 | Sets a finite number of loops from 1 to 240 repetitions. |
| | | SUSTN | The loop will continue to cycle as long as notes are being played or the Sustain Pedal is down. |
| | MONLEG Mono Legato | OFF, ON | When ON, this parameter allows the sequence to be transposed in the middle of its cycle when you play <i>legato</i> . |
| | ZOOM Sequencer Zoom | OFF, ON | When ON, the sequencer graph will be magnified so you can see smaller note changes. |
| | USEKBD Use Keyboard | OFF, ON | When ON, this allows you to enter sequencer notes using the A6's keyboard. |

TRIG Parameters

| PAGE | PARAMETER | OPTIONS or RANGE | DESCRIPTION |
|------|-----------|---|--|
| TRIG | SOURCE | Many of the MOD sources such as Mod Wheel, Ribbon, Footswitch, etc. | <p>This parameter allows you to select an input that will trigger the sequencer. Unlike other MOD source menus, nothing involved with a voice is on the list, since the voices themselves are being triggered by this function.</p> <p>The selected trigger source is activated when certain conditions exist. Specifically, when the selected trigger's LEVEL and TYPE (described below) are detected, the trigger is activated.</p> <hr/> <p>The A6 gets its signal to generate a trigger when the SOURCE reaches a certain LEVEL that you set (next page) and when the source is "moving" in a positive or negative direction, or both (next page under TYPE - polarity type).</p> |
| | LEVEL | -100 ... +100 | <p>This sets the level of the SOURCE (selected above) where triggering will take place.</p> <p>Note that if the POLAR setting (below) is set to one of the absolute (ABS) options, negative settings are treated as if they were positive.</p> |
| | TYPE | NEGATIVE BIPOLAR POSITIVE | <p>The trigger will occur only when the source is "moving in a negative direction." This means that a trigger is generated when the LEVEL setting is reached, but only if the source is decreasing in amplitude.</p> <p>The trigger occurs when the LEVEL is reached but the source can be either increasing or decreasing in amplitude.</p> <p>The trigger will occur only when the source is "moving in a positive direction." This means that a trigger is generated when the LEVEL setting is reached, but only if the source is increasing in amplitude.</p> |
| | | ABS: Absolute | <p>– the following polarities treat positive and negative LEVEL settings as if they were all positive.</p> |
| | | ABS NEGATIVE | <p><i>Absolute Negative:</i> a trigger is generated when the source is moving in a negative direction and reaches the absolute value of the LEVEL.</p> |
| | | ABS BIPOLAR | <p><i>Absolute Bi-Polar:</i> a trigger is generated when the source is moving in a either direction and reaches the absolute value of the LEVEL.</p> |
| | | ABS POSITIVE | <p><i>Absolute Positive:</i> a trigger is generated when the source is moving in a positive direction and reaches the absolute value of the LEVEL.</p> |

| PAGE | PARAMETER | OPTIONS or RANGE | DESCRIPTION |
|-------------------|-----------|------------------|--|
| TRIG Continued | RETRIG | OFF, ON | Turns re-triggering on or off. When off, the trig source acts as a one-shot trigger. When on, the trigger acts repeatedly, restarting the sequence from the beginning. |
| | ENABLE | OFF, ON | Turns the trigger on or off. |
| | TRGVOX | | Determines which voice triggers the sequencer. |
| | | FIRST | The first voice to play will trigger the sequencer. |
| | | OLDEST | The oldest voice playing will trigger the sequencer. |
| | | NEWEST | The newest voice playing will trigger the sequencer. |
| | MODE | | This parameter determines how voices are played once a trigger or multiple triggers occur. |
| | | NORMAL | One trigger plays the sequence according to the CONFIG page settings. |
| | | STAGE | Requires multiple triggers: each Step (“stage”) in the sequence plays in order if each new trigger has a different level . |
| | | ADVANC | Requires multiple triggers: each Step plays in order with each new trigger. |
| | | RANDOM | Requires multiple triggers: each Step plays at random with each new trigger. |

PROGRS Parameters

The Progressor allows for automatic transposing of the sequence within the limits set by the MIN and MAX parameters. Although the PRGRSR is the first parameter on the screen, you should set the MIN and MAX limits first, then adjust the PRGRSR value.

Using 0 as the *base note* (the key that’s being played) value, the MIN value sets the low end of the note range where transposing takes place. Conversely, MAX sets the upper limit of the note range where transposing takes place. Although both of these parameters have a -127 to +127 range, the most useful limits will be within a few octaves (-24 to +24 settings).

The PRGRSR value determines the transpose amount. A setting of 1 means that the sequence will transpose **up one semitone** starting at the MIN note with each repetition of the sequence until the MAX note limit is reached. A PRGRSR setting of -1 means that the sequence will start playing at the MAX key and transpose **down one semitone** with each repetition until the MIN note limit is reached.

SYNC Parameters

| PAGE | PARAMETER | OPTIONS or RANGE | DESCRIPTION |
|------|-----------------------------------|------------------|--|
| SYNC | SYNSRC Sync Source | | Allows you to select the clock source that will drive the sequencer. |
| | | LOCAL | Uses the sequencer's dedicated clock for its tempo. |
| | | CLOCK | Uses the A6's global Clock for tempo. |
| | | MIDI | Uses an external MIDI device for tempo. |
| | STPSIZ Size of Sequencer Steps | 2 ... 11904 | <p>Allows you to designate the size of each sequencer step. The default is a quarter note or 24 clock ticks. Using the soft pot to adjust this parameter gives you the most commonly used values. The increment and decrement buttons allow finer adjustment for odd values.</p> <p>Note that in Mix Mode, each mix channel's step size setting will override the program's step size setting. This allows you to have a different step size setting for a program in Mix Mode than in Program Mode.</p> |

About Tempos and STPSIZ

The SYNC page features a tempo display that can help you match the speed of the clock to musical values. This display calculator assumes that 24 ticks equals a quarter note, and that the music is in 4/4 time. If SYNSRC is set to CLOCK, and STPSIZ is set to 24, the display will read:

Qtr Note

and each step of the sequencer will last a quarter note. If you want the sequencer to play twice as fast, set STPSIZ to 12 and the display will read 8th Note.

If you want odd step values, use the increment and decrement buttons to adjust the length by one tick increments.

MOD Parameters

The modulation page for the sequencer is identical to the SYNC/MOD page for the Clock. See page 71.

ARPEGGIATOR

Similar to a sequence, an *arpeggio* is musical term that refers to the playing of notes of a chord one after another instead of playing them simultaneously. The A6's Arpeggiator is used to create **programmable** arpeggios – Arpeggiator settings are made per Program and stored in memory with each Program. An arpeggiator is extremely versatile in that intricate patterns of notes can be constructed that would otherwise be extremely difficult, if not impossible, to play manually. Also, arpeggios can be played faster than is humanly possible, or span octaves above or below the physical limits of the keyboard.

The A6 Arpeggiator is nearly identical to the Sequencer in its basic design. The main difference lies in the display layout and what you're playing on the keyboard (or what the A6 is receiving via MIDI In).

Also, unlike the Sequencer, the Arpeggiator is a **per Voice** function rather than a per Program function. This means that each **playing voice** is linked to its own arpeggiator. This results in 16 arpeggiators – one per Voice – each with their own status, position, and voice variables.

The Arpeggiator TRIG, PROGRS, SYN and MOD parameter pages are identical to those of the Sequencer (refer to pages 76 through 78 for the information). The only different set of parameters exist on the CONFIG page which is covered on the next page.

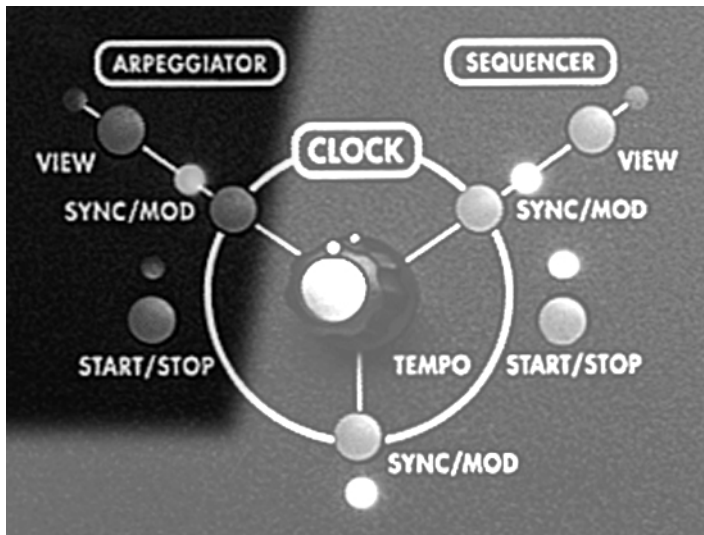

the current settings without making any changes. You can, of course, change any setting but you don't have to when using a **VIEW** button.

START/STOP Button

Enables and disables the Arpeggiator. This is a programmable function for all voices in Programs or Mixes.

SYNC/MOD Button

Pressing this button displays the Arpeggiator's SYNC page on the screen. This page of parameters allows you to set the source of the Arpeggiator's tempo.

VIEW Button

Pressing this button recalls the page of Arpeggiator parameters that was last used (it defaults to the CONFIG page). Using this button to enter the Arpeggiator edit mode allows you to examine

Arpeggiator CONFIG Parameters

| PAGE | PARAMETER | OPTIONS or RANGE | DESCRIPTION |
|--------------------------------------|------------------|---|--|
| CNFG Arpeggiator Configuration | LOCBPM | .46 ... 600 | The speed or rate of the Arpeggiator displayed in “bpm” or beats per minute. This setting is independent of any TEMPO setting for the Clock or Sequencer, and is only effective when the Arpeggiator is set to LOCAL in the SYNC menu. |
| | Beats per Minute | | |
| | LENGTH | 0 ... 100 | Modifies the Release 2 times of the envelopes. |
| | OCTAVE | -10 ... +10 | Sets the number of octaves the arpeggio will play. 0 indicates that a held chord will only arpeggiate the notes actually held. Positive values transpose the arpeggio up that number of octaves; negative values transpose the arpeggio down that number of octaves. |
| | CENTER | OFF, ON | Places the held notes in the “center” of the arpeggio: if the OCTAVE parameter above is set to 3, the arpeggio will play three octaves above and below the chord played. |
| | TYPE | Determines the direction the Arpeggiator will play notes: | |
| | | FORWRD | The arpeggio will play notes in order from the lowest to the highest, and additional octaves (as set in the OCTAVE parameter, above) from lowest to highest. |
| | | REVERS | The arpeggio will play notes in reverse order from the highest to the lowest, and additional octaves (as set in the OCTAVE parameter, above) from highest to lowest. |
| | RNRINC | <i>Rock-n-Roll Inclusive</i> – the sequence will play the arpeggio forward then in reverse, including the end notes twice: once when completing the forward direction and once when starting the reverse direction. | |
| | RNRCIR | <i>Rock-n-Roll Circle</i> – the sequence will play the arpeggio forward then in reverse, but will not play the end notes twice as in RNRINC. | |
| | CHORD | OFF, ON | When off, a held chord arpeggiates as single notes. When on, a held chord is heard as a chord along with its arpeggiated notes. |
| | LATCH | UNLATCHED LATCHED | Latch keeps the arpeggio playing after you let go of the keys. This function uses soft button 7 and is available when any Arpeggio page is displayed. |
| | RUN | STOPPED RUNNING | Turns the arpeggio on or off. This function uses soft button 8 and is available when any Arpeggio page is displayed. |

CHAPTER 3

BASICS OF ANALOG SYNTHESIS

AN OVERVIEW OF SYNTHESIS

The concept of a synthesizer is an instrument that is capable of producing a very wide range of sounds electronically. The huge popularity and continued development of synths since the late 60s is due, in great part, to this ability to offer so many different types of sound textures in one box.

A synthesizer's ability to produce such an incredible variety of sound comes from its basic design: it **electronically simulates the fundamental components of sound and gives you control over each part**. The term *synthesize* means to "to combine parts into a whole". And that's exactly what a synthesizer does: the essential ingredients of sound are presented on the front panel as separate parts which are then "re-assembled" as an audible sound.

ANALOG AND DIGITAL TECHNOLOGIES

In today's world, the majority of electronic keyboards are digital. Although the first synthesizers were analog, the demand for digital products led the market away from analog designs. But because analog instruments have a sound quality all their own, and because they operate somewhat differently than their digital cousins, there's been sort of a revival of interest in this technology.

So if this is your first analog synthesizer, or your first synthesizer ever, you might be wondering what the difference is. Briefly, a digital instrument is **completely dependent on its microprocessor(s) and memory for the sounds it makes** and any control and sound-modifying functions.

An analog instrument uses electronic circuitry for sound creation and filtering that is **not** dependent on its computer chip. While the instrument's processor provides many control and memory functions, **the basic sound path is in the hardware that is separate from the microprocessor**. In the early days of synthesizers, **everything** in the unit was analog, which involved many transistors, resistors, capacitors, diodes and coils of wire, and often meant no program memory, frequent manual tuning, limited sound-modifying abilities and relatively high cost.

But where did all this start?

A LITTLE HISTORY

Electronic music as we know it today began years ago with musicians and physicists analyzing and experimenting with sound. Sound, as we might remember from high school physics, is created by an object vibrating the air causing *sound waves* – minor fluctuations or changes in air pressure that we perceive or experience with our ears as audible sound. The people who studied this natural phenomenon from a musical perspective put audible sound into two categories: sound that has a musical pitch and sound that doesn't.

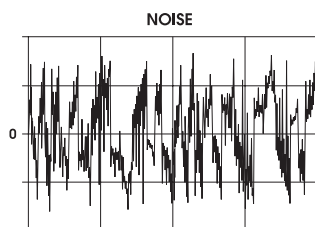
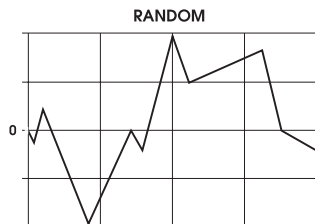
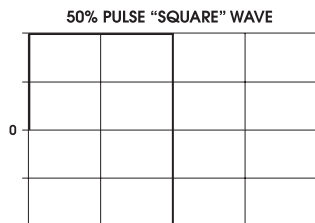
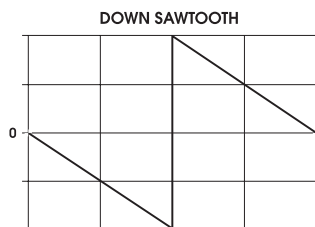
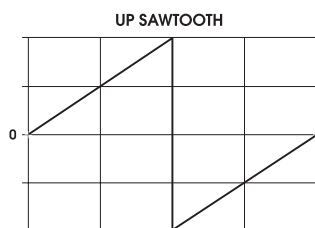
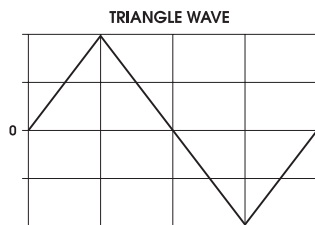
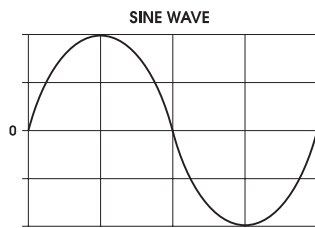

For both pitched and non-pitched sounds, there are two key elements of sound that we will be working with when creating or editing Programs on the A6. First, we need to consider what makes up a sound wave: what are the components of a sound wave and how do they relate to the A6? Second, we need to know that sound changes over a period of time, which can be a mere fraction of a second to several minutes (or longer). Let's take a few moments to cover these two elements.

A LITTLE THEORY

WAVEFORMS

All audible sound consists of *waveforms* or *waveshapes*. These are the vibrating air waves our ears perceive as sound, and can be described by their "form" (or the "shape" of the wave) when depicted by a graph. Waveforms can be illustrated by simple graphs that show how they would appear on the display screen of an *oscilloscope*, an electronic device used to analyze sound waves. The graphs in the left column illustrate what the basic waveforms look like.

Waveforms are the primary components of the "raw" sound in a synthesizer. But instead of a "vibrating object", these waveforms are generated electronically. This is the function of an analog synthesizer that we mentioned just a moment ago: the electronic approximation of sound waves that occur in nature.

The A6 uses 32 *oscillators* – electronic circuits that produce raw waveforms – to simulate naturally occurring sound waves. For our purposes in operating the A6, we'll classify waveforms into two types based on their shape:

- *Cyclical* or *periodic* waves repeat a particular pattern over and over. **The main property of a periodic wave is that it has a musical pitch or tone.** Periodic waves, therefore, are especially useful when attempting to synthesize traditional instruments such as violins and other stringed instruments, brass and horns, reed instruments and so forth. By the same token, periodic waveforms are useful when synthesizing entirely new sounds that don't sound anything like a violin or a clarinet.

The A6 provides four periodic waveforms which are described by the shape of the sound wave they create: Sine, Triangle, Pulse and Sawtooth. These four basic waveforms have distinct sound personalities and lend themselves to producing certain kinds of sounds as we will discover later.

- *Non-cyclical* or *aperiodic* waves are irregular and do not have any particular pattern that is repeated. The main property of a non-cyclical wave is that it does **not** have a musical tone. Aperiodic waves, therefore, are especially useful when synthesizing wind, thunder, explosions or

mechanical sounds. Clever use of aperiodic waves, often in combination with periodic waveforms, have resulted in sounds that closely resemble drums, cymbals and helicopters. The A6 provides two of these non-cyclical sound sources called Random and Noise.

Central to all sounds are two properties *frequency* and *amplitude*. Frequency is another word for pitch. Low notes on a musical instrument, for example, are said to have a low frequency; high pitched notes have a high frequency. Amplitude is commonly associated with “amount” and often (but not always) refers to the volume level of a sound: high amplitude means loud, low amplitude means soft or quiet. Frequency and amplitude are also used to describe the properties of control signals that are not audible themselves – you can’t actually **hear** a vibrato signal, but you can hear the **effects** of it when applied to a sound. More on that later.

FUNDAMENTALS AND HARMONICS

Periodic waveforms, when analyzed further, reveal that they actually are composed of **numerous waves** that combine to make up the sound that we hear. The primary wave, called the *fundamental*, establishes the pitch or note value of the wave. It is also the loudest of all the waves that comprise a sound.

In addition to the fundamental wave, a series of waves are present in each sound that are **related** to the fundamental. Called *harmonics* or *overtones*, these waves are responsible for the waveform’s *timbre* (pronounced *TAM-ber*) or tonal identity. For example, Sine and Triangle waves sound “flute-like” with the Triangle wave sounding a little brighter due to its harmonics (a Sine wave is simply a fundamental wave without harmonics). A Sawtooth wave, which has a certain harmonic structure, sound “raspy” while the Square wave, having another set of harmonics, sounds “hollow”. Variations on the Square wave, accomplished by varying the **width** of the pulse, sound less hollow as the pulse width becomes narrower, to “nasally” at the narrowest setting.

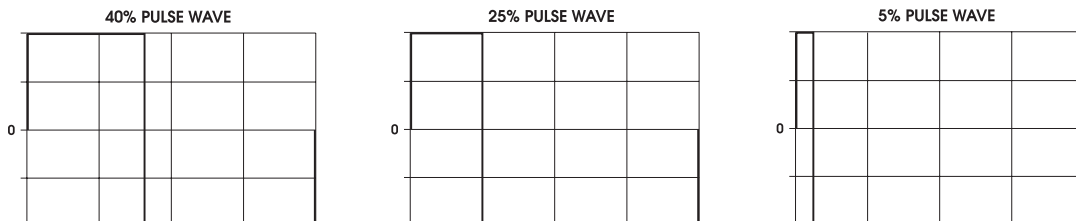

Harmonics, like other periodic waves, have frequency and amplitude. Their frequencies are musical intervals above the fundamental which can be thought of as the “root”. Their amplitudes are also based on the loudness of the fundamental: each harmonic diminishes in amplitude as you get further away from the fundamental.

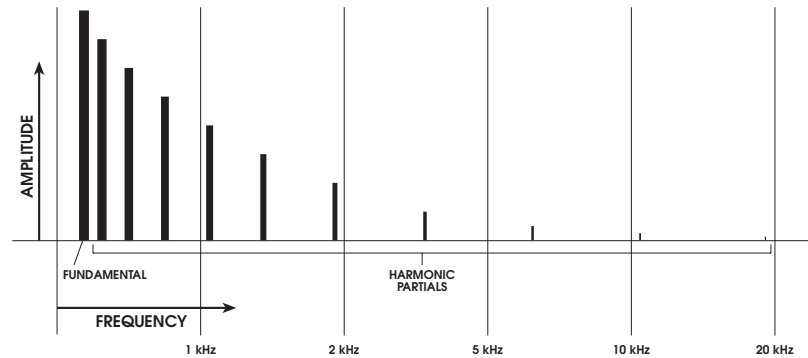

Harmonics also determine if the waveform is perceived to be “bright” or “muted”: the more harmonics present in the waveform, the brighter the sound appears to our ears. This is where *filters* come in.

In an analog synthesizer, the harmonic content of the sound is controlled by the filters: circuitry that controls the amount of harmonics present in the Program. By its very name, it’s implied that these circuits “filter out” harmonics. This is true: the filters provide a range or *bandwidth* of harmonics, sometimes called the *spectrum*, that the sound will contain by filtering out or removing the harmonics of a waveform generated by the oscillators. It is also possible to set the filter “wide open” (at maximum) so that all of the harmonics are present.

SOUND DYNAMICS

Most of us aren’t conscious of this, but virtually every sound we hear every day is *dynamic*: audible sounds make subtle yet significant changes as we are listening to them. Take a piano note, for example. When a key is played and held down, the sound the vibrating strings make goes through numerous fluctuations as the note fades out. When the hammer first strikes the strings, this initial “hit” is the loudest and the brightest part of the sound. As the note fades, notice that not only is there a gradual decrease in loudness but also in brightness as well.

Consider the differences in loudness and tonal quality that different playing styles have on just about any acoustic instrument. Think about how *staccato* playing sounds different than playing *legato* on the same instrument.

Envelopes

A synthesizer provides a number of electronic controls that are used to shape or contour the overall sound as it plays out over the duration of the note. We’re not referring to Velocity, Aftertouch or Pressure here but the synthesizer’s *envelopes*: electronic circuits that you can set to shape the loudness and the brightness (or lack of it) of the sound as it plays out.

Here's a graphical representation of a typical envelope. We'll be covering the details of how an envelope works, what you can do with it and what all those labels mean in a later chapter. For now, we just want to show you how an envelope is graphed (especially since the A6's screen will display something like this when you're editing an envelope in a Program).

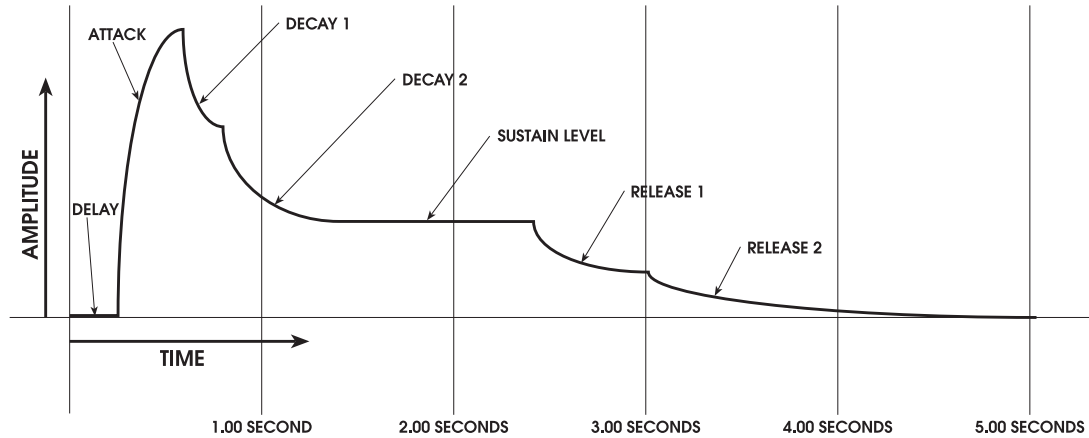

Since sound waves have *polarity* – both positive and negative properties (a kind of “pushing and pulling”) when moving air – a sound’s envelope also has polarity. Using the envelope above to shape a sound wave’s **volume**, the wave as we might hear it could look like this:

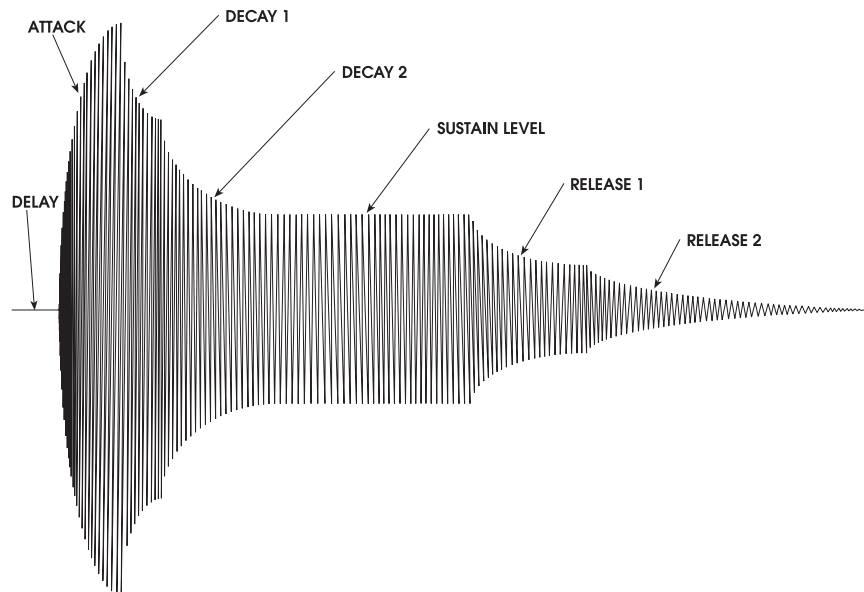

LFOs

In addition to loudness and brightness dynamics, everyday sounds are often enhanced with repeating, patterned fluctuations we recognize as vibrato. In one of its more expressive applications, a singer often adds vibrato at the end of a sustained note. As an extreme example, you can think of the high rise and fall of a police siren as vibrato on steroids.

A synthesizer uses Low Frequency Oscillators (LFOs) to introduce vibrato to the sound. Designed much like the oscillators that produce raw waveforms as the synth's primary sound source, LFOs are not heard but are used to *modulate*, or change, many components of the sound that you **can** hear: the oscillators, filters, overall loudness and many others.

LFOs use the same waveform types as the oscillators, but their frequency range is much lower (hence the term "low frequency") because the typical speed of LFO modulation is below the range of an audio oscillator. Using our original graph of a sine wave on page 82, the following illustration shows how this wave affects a sustained note.

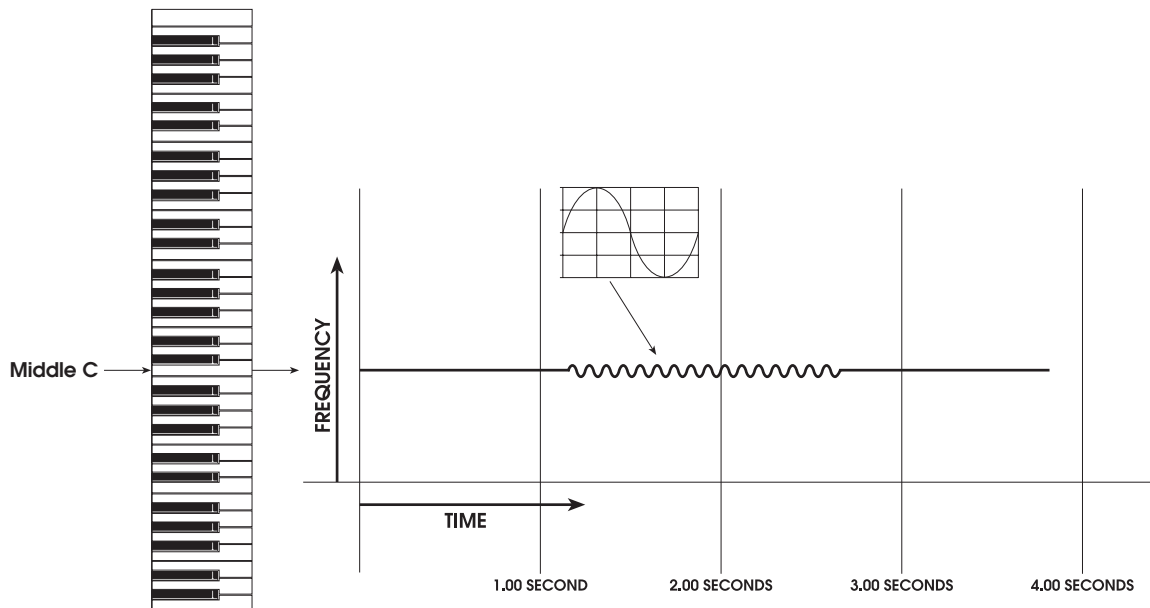

COMPONENTS OF AN ANALOG SYNTHESIZER

With the preceding information as background, let's take a look at how our discoveries about sound relate to a physical electronic instrument. Here's a series of flowcharts illustrating this concept that we will build upon over the next few pages:

1. In its most rudimentary form, the heart of synthesizer is really nothing more than a group of oscillators (to provide the raw sound), feeding the filters (to control the harmonic content of the sound), feeding the output of the instrument (where the final volume level is set).

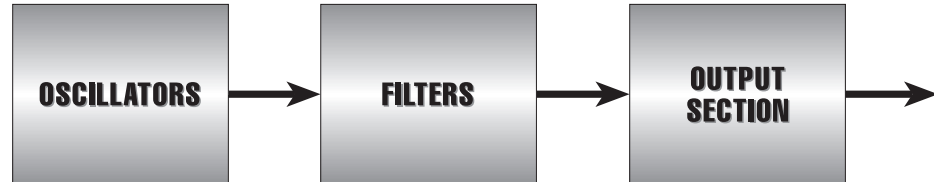

2. Now we start adding **controllers** – hardware that gives the instrument playability and expression – and **modulation** – circuitry and/or software that is used to shape or vary the sound.

First up is the keyboard controlling the pitch of the oscillators:

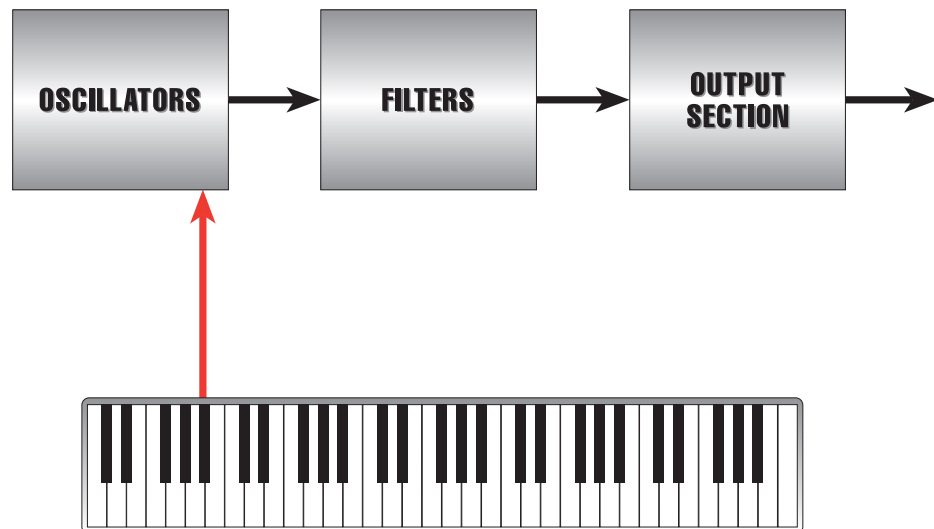

3. As the keyboard is played, low notes output low frequencies from the oscillators and high notes play high frequencies. Similarly, the filters can be scaled as well. So it makes sense that the keyboard control be routed to the filters so that low notes played on the keyboard cause the filter to “close” and output fewer harmonics; high notes on the keyboard cause the filters to “open” and output more harmonics. This type of scaling causes notes across the keyboard to have an even amount of brightness:

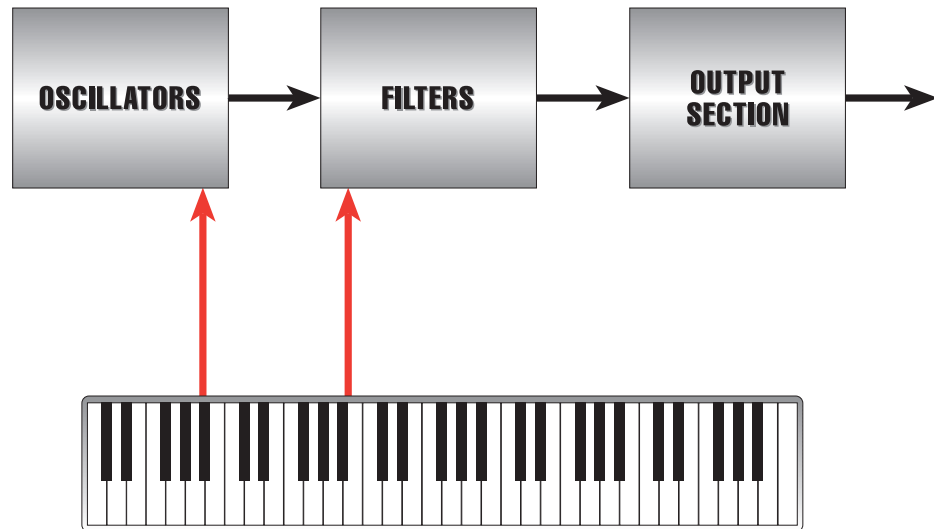

4. Envelope modulation is introduced into the signal flow so that the harmonic content (the envelope modulating the filters) and the overall loudness (the envelope modulating the output section) of the sound can be shaped. This shaping is controlled by you as you set the envelopes' time and amount parameters.

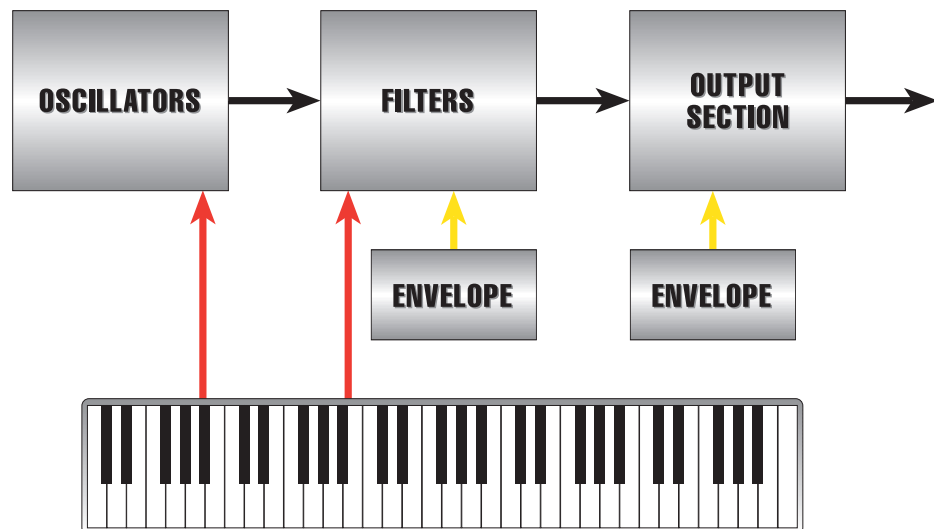

5. The keyboard is also responsible for gating the envelopes. In essence, this is really what causes the synthesizer to make a sound. When the envelopes start, they “open” and allow the filters and the output section to pass sound from the oscillators:

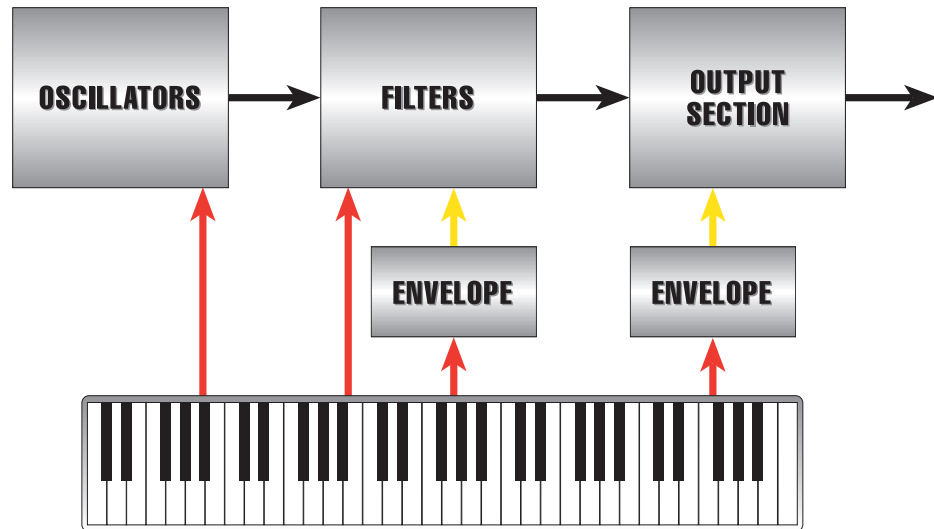

6. But what about pitch bend and vibrato controllers? Pitch bend routes a wheel directly to the oscillators so as to allow you to manually vary their pitch. Vibrato uses a wheel that sends a variable amplitude (amount) to an LFO that in turn varies the pitch of the oscillators up and down slightly:

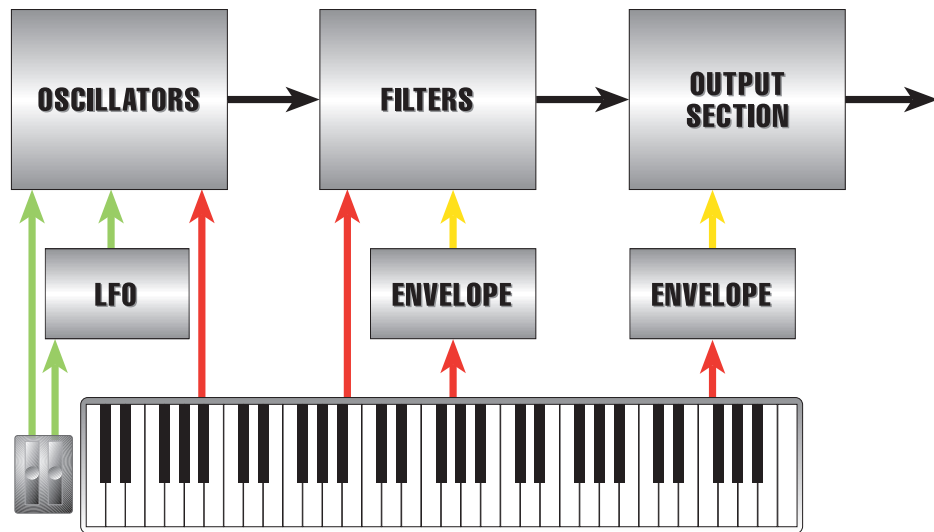

7. Last, but not least, we'll add controller inputs for volume pedal and sustain pedal. Typically, a volume pedal varies the amplitude (again the "amount") of the synth's output section.

Sustain pedal control is typically routed to the Release portion of the envelopes: the stage of the envelopes that controls the time it takes for the fundamental and harmonics to fade out.

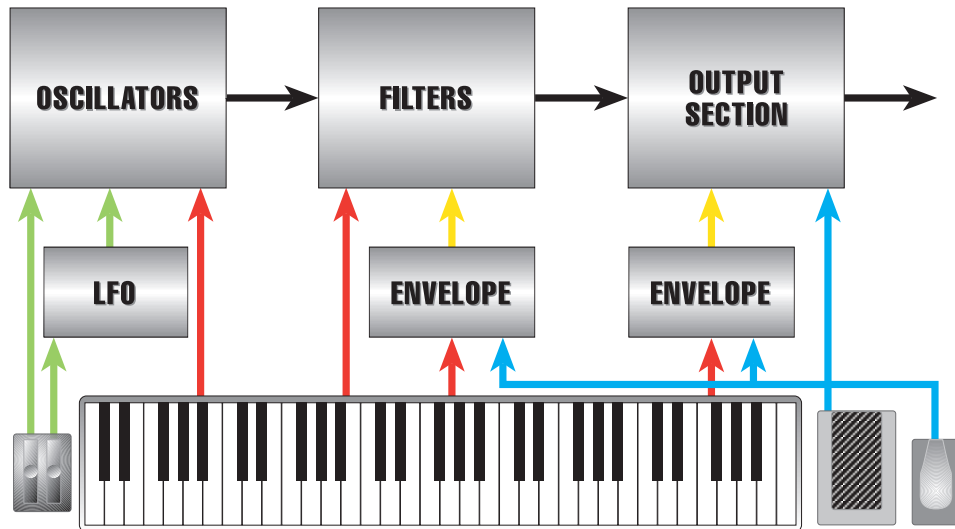

Note: The keyboard, pitch bend and vibrato wheels, plus sustain and volume pedals pictured here as physical controllers can also be incoming MIDI information.

This covers the material for our starting point in introducing the concept of analog synthesis. In the next Chapter, we'll apply all of this wonderful knowledge to the design and operation of the A6, including a comprehensive feature list.

CHAPTER 4

OVERVIEW OF THE ANDROMEDA A6

MAKING SENSE OF ALL THIS THEORY: AN OVERVIEW OF THE A6

Now that we've covered the bare-bones basics of analog synthesis, we can move on to see how all this theory applies to the A6.

As analog synthesizer technology developed over the years, it became more feasible to not only add more sound-modifying features (additional oscillators, two filters per voice rather than just one, more envelopes, more LFOs, etc.) but add more functionality as well. For example, early analog synthesizers had simpler envelopes with just Attack, Decay, Sustain Level and Release parameters. Advances in technology allowed the addition of a Delay portion as well as a second Decay stage and a second Release stage for more precise articulation of envelope shaping.

In addition, further refinement of analog synthesis allows the routing of standard sound modifiers to more elements of the sound than ever before. In fact, "modifying a modifier" is not only possible but commonplace. Consider modulating an LFO's speed by an envelope or another LFO, or the keyboard, or the sustain pedal, or dozens of other sources you wouldn't normally think of using. Later in this manual, we'll explore how the A6's audio mixing capabilities provide ways to combine filtered and unfiltered sounds, creating an incredible wealth of new textures. These are just a few highlights of how synthesis has grown and matured.

The A6 represents the latest and most comprehensive set of sound creation tools yet in an analog synthesizer. You'll find all of the necessary ingredients we just covered plus countless more, including a full complement of studio-quality stereo effects and external inputs.

A FEW BASIC CONCEPTS

The design of the A6 follows conventional wisdom in the way many of its functions are organized. But that's where many synth players, especially those who are new to these instruments, get confused. Here, then, are a few fundamental principles that will help you understand how the A6 is laid out.

Essentially, the A6 operates in one of two **play** modes: Program mode or Mix mode. The third mode, Global, is not a play mode but a **operating** mode where the A6's master settings are made. There will be more said about Global functions later in this Chapter.

Program Mode

In Chapter 3, we defined a *Voice* as the most basic component of a synthesizer that produces sound: the physical circuitry (the "hardware") that generates audio.

A *Program* is the basic group of sound **settings** for a Voice – the pitch or tuning, harmonic content and shape, loudness, etc. – that are used to create the Voice's tonal identity: does it sound like a flute, a trumpet, a violin, a truck, a helicopter, or a dog bark?

In the A6, all of a Voice's settings are stored in memory for instant recall. So, all of the settings that you use to create a sound are "programmed" into the A6's memory, hence the term Program for referring to a sound stored in memory.

In **PROGRAM** mode, all 16 of the A6's Voices get the same Program information and therefore play the same sound. Playing keys on the keyboard or receiving MIDI notes all play the same sound. Things start to get interesting when you put the A6 into **MIX** mode where you take existing Programs and combine them in a wide variety of ways as described in the next topic.

Mix Mode

As the name implies, a Mix is comprised of two or more Programs. Using the A6's **MIX** mode, **existing** Programs are combined to create multi-textured sounds. In its most extreme application, each of the 16 voices can be set to play a different Program. Although rarely used, this can be accomplished quite easily.

But what about standard splits and layers? Mix mode is where splits and layers are set up and programmed for instant recall using existing Programs. The procedures for setting up splits and multi-splits, layers and multi-layers, and splits-with-layers are covered in detail in Chapter 6. Mix mode is also commonly used for multitimbral operation with an external MIDI sequencer.

External Memory

The A6's **RAM EXPANSION CARD** port on the back panel is ideally suited for use with the Alesis 512k PCMCIA Type I RAM card (PC Card). This is a credit-card-sized memory module that adds additional Program and Mix memory for you to store your own creations in addition to the User bank. Note, however, that Alesis QCards™, which are ROM cards with sample memory designed for use with the Alesis QS series, will not work in your A6.

The A6 supports 256K, 512K, 1MB and 2MB RAM cards. Larger sizes will work but will only be "seen" as 2MB by the A6.

Using a PCMCIA RAM card provides additional storage space for you to store both Programs and Mixes that you create. A RAM card also makes an excellent backup device that is both convenient and fast. Refer to Chapter 2 for the procedure to format and store sounds on the external RAM card.

External sounds from an Alesis RAM card can be used for single Programs and Mixes. They can also be combined with internal sounds, both Programs and Mixes. This opens up new possibilities when creating layers and splits.

A6 FUNCTION LIST

We continue with a list of A6 functions. Each function will be explained in the section following this list. Detailed descriptions will be covered throughout this manual.

Memory

- 256 factory Programs (in Flash memory)
- 128 user-programmable Programs
- 128 factory Mixes (in Flash memory)
- 128 user-programmable Mixes

Tone Sources

- 32 true analog Voltage-Controlled Oscillators (2 per voice) w/ hard and soft sync and sub-oscillation
- 3 external audio inputs (-10dB):
 - one input to Voice 15 Filters, one input to Voice 16 Filters and one Mono Input to All filters
- 1 full-spectrum analog Noise Generator, capable of producing White, Pink and Red noise

Tone Modifiers

- 32 true analog Voltage-Controlled Filters w/ resonance (2 per voice)
 - Filter 1: dynamic 2-pole low-pass, high-pass, band-pass and notch
 - Filter 2: dynamic 4-pole low-pass
- 16 Ring Modulators (1 per Voice)

Modulation Sources (per Voice)

- 3 Low Frequency Oscillators
- 1 Sample-and-Hold generator
- 3 multi-stage, multi-mode Envelopes
- 1 multi-stage Tracking Generator

Audio Mixing

- 3 in-line signal level controls: Pre-Filter Mix, Post-Filter Mix and Voice Mix to final out through true analog Voltage-Controlled Amplifiers

Controllers

- 5-octave (C-to-C) velocity, aftertouch and pressure-sensitive semi-weighted keyboard
- Modes: full, layer and split w/ polyphonic, monophonic and unison voicings
- assignable Pitch and Modulation wheels
- assignable, splittable Ribbon controller
- rear-panel Volume and Sustain pedal inputs
- rear-panel Oscillator and Filter control voltage inputs
- Real-time Arpeggiator
- 16-event, programmable Step Sequencer, 1 per Program
- Master Clock control

Effects

Analog distortion
Stereo reverb (Large Hall, Hall, Stereo Hall, Room, Chamber, Ambience,
Large Plate, Plate, Hall/Room, Plate/Room, Hall/Plate, Nonlinear)
Delays (Mono, Ping-Pong, Multi-tap, Dual)

Chorus (Stereo Chorus/Flanger, Quad Chorus, Dual)
Flange
Quad pitch shifter
Multieffects (Rotary>Room, Delay>Room, Chorus>Room, Room>Flange,
Flange>Delay>Room, Room+Delay, Room+Chorus, Room+Flange,
Room>Delay)

Display

240 x 64 multi-function back-lighted LCD

Master Controls

Master Volume
Master Tune w/ AutoTune function
Global Transpose

Rear Panel Inputs & Outputs

| | |
|-------------------------|---|
| RAM Expansion Card slot | PCMCIA Type I card slot |
| MIDI | In, Out and Thru |
| Pedals | Sustain pedal, footswitch, pedal CV |
| Control Voltage inputs | Oscillator, Filter |
| Filter audio inputs | Mono to all, Voice 15 filter, Voice 16 filter |

Audio

| | |
|--------------------------|---------------------------|
| Individual Voice outputs | eight stereo 1/4" jacks |
| Auxiliary audio outputs | two mono 1/4" jacks |
| Main outputs | Left and Right 1/4" jacks |
| Headphones | stereo 1/4" jack |

Power

| | |
|---------------|---|
| AC receptacle | standard 3-prong recessed male receptacle |
|---------------|---|

A6 FUNCTIONS AT-A-GLANCE

Memory

The A6 contains enough memory for three banks of 128 Programs and two banks of 128 Mixes. The Preset banks contain the 256 Preset Programs and 128 Preset Mixes we created for the A6 and are stored in semipermanent memory called Flash memory. The User bank contains 128 Programs in programmable memory that you can modify to your liking, or use to store your own Programs (128 memory locations) and Mixes (128 of those, too).

Mixes are memory locations that take existing single Programs and allow you to combine them. Examples of this combining of Programs in a Mix would include layering (two Programs played by one note), and keyboard splitting (the lower range of the keyboard plays one Program such as a bass sound, and the upper range of the keyboard plays another Program such as a solo or accompaniment). It is possible to make any combination of layers and splits, with up to 16 programs playing at once. Mix mode is also used when you want to have multitimbral control from a sequencer, or use the A6 as a MIDI master keyboard controlling other synthesizers and modules.

Programs are selected by using the row of buttons just above the Ribbon Controller. The 2-digit buttons select the group of 10 and the single-digit buttons select the specific Sound or Mix.

Audio Sources

Referring back to Chapter 3, we covered the basic ingredients of sound and the corresponding components of a synthesizer. Using our first flowchart as an example, the oscillators are the primary sources for raw sound in the A6. To be more specific, the oscillators provide the periodic waveforms used to create sounds with musical pitch.

The A6's oscillators are true analog Voltage-Controlled Oscillators, hereinafter referred to as the VCOs or by their panel labels **OSC 1** and **OSC 2**. As in the early days of analog synthesis, the frequency of an oscillator – what musical note it plays – is determined by the voltage it is sent by the keyboard (or other controller such as the Pitch Bend wheel, Vibrato wheel, etc.). Low voltages produce low notes and high voltages result in high notes. Although the A6 has a digital keyboard and also responds to incoming MIDI data, its processor's data stream that controls the VCOs is converted to an analog voltage first, then is sent to the VCOs. In addition, each of Andromeda's VCOs produce *sub-oscillation*: each VCO outputs a sine wave one octave below its **SEMITONE** tuning.

Aperiodic waves are provided by the A6's Noise Generator, a *full-spectrum* (containing the full range of frequencies) noise source for creating Programs simulating wind, thunder, earthquakes and various mechanical sounds.

The A6 also provides three 1/4" input jacks on the rear panel that allow you to connect, for example, another synth, electric piano or guitar and process these signals through the A6's Filters and Output stages. Through these inputs, you can connect your external audio to the Filters of either Voice 15 or Voice 16 (or both for stereo), or a mono signal to all Voices.

Tone Modifiers

Filters

Referring back to Chapter 3 again, the second component in the signal flow is the synthesizer's Filters – the circuitry that controls the harmonic content of the sound wave. Like the A6's VCOs, its filters are true analog Voltage-Controlled Filters. We'll refer to them throughout the rest of this manual as VCFs or by their panel labels **FILTER 1** and **FILTER 2**.

The A6's VCFs operate by **removing unwanted frequencies** from the sound waves generated by the VCOs, the Noise Generator or audio signals input to the A6 via the **EXT FILTER INPUTS** on the unit's rear panel. This is commonly referred to as *subtractive synthesis* whereby the VCOs, for example, generate a full spectrum of harmonics, and the VCFs are used to "filter out" unwanted overtones. If the sound you are creating calls for the full range of harmonics to be heard, you can either "open up" the VCFs by turning their **FREQ** controls fully clockwise or press the **FILTER BYPASS** button.

Although both VCFs appear to have identical controls, they are quite different. **FILTER 1** is a *multi-mode* filter – it filters harmonics in several ways. **FILTER 2** is a single mode filter – only one type of harmonic filtering is accomplished by this circuit. We'll cover these modes in detail in Chapter 5.

Last, the A6's VCFs are designed such that the output of **FILTER 1** can be routed into **FILTER 2**. This allows additional control over the harmonic content of the sound wave by providing a means of "filtering a filter".

Ring Modulator

The A6's Ring Modulator, labeled on the front panel as **RING MOD**, is another classic analog tone modifier. It generates a series of sum-and-difference overtones from the input signals, resulting often in a metallic, distorted character that is frequency-dependent. For more on Ring Modulation, see Chapter 8.

Modulation Sources

The term *modulation* means "to change". Musically, we use the term modulation when referring to a key change in a composition. In the world of synthesis, the concept of change applies to any control that causes variation to the original sound wave over a period of time.

The A6 offers the common sources of modulation in a synthesizer: Low-Frequency Oscillators, Envelopes, and the Tracking Generator. (Strictly speaking, however, **any** change to the sound wave's components would be considered a mod source. The keyboard, for example – and for that matter incoming MIDI notes – would be considered a modulation source because it changes the frequency of the VCOs.)

The A6's Low-Frequency Oscillators – hereinafter referred to as LFOs – are similar to the A6's VCOs in that they produce periodic waveforms. The difference is in the "low-frequency" designation: LFOs produce waveforms whose frequency or pitch is usually below our threshold of hearing. Because of this, LFOs aren't considered a source of sound in the A6 and are not part of the audio path. They're only used for modulation.

Because of their low-frequency nature, LFOs are not only perfect for the familiar vibrato and trills, they provide a virtually unlimited source of special effects. In addition to the periodic waves, a fourth LFO in the A6 provides *Sample-and-Hold* modulation – **S & H** on the front panel – a classic analog mod that produces a **random** modulation wave.

The A6's Envelopes are the time-dependent modulators we introduced in Chapter 2. Commonly used to shape the harmonics (**ENV 2 (FILTER)**) and overall loudness (**ENV 3**

(AMP) of the sound wave, an Envelope can also be routed to a VCO for pitch changes. For this purpose, **ENV 1** is routed to the frequency of **OSC 2**. via a rotary front-panel control; it can also be routed to **OSC 1**.

The Tracking Generator, found on the A6's front panel under the **PROCESS** label and as a MOD source in many display windows, is a circuit that is used to "reshape" a modulation source. A good example of this is using the Track Gen to reshape the keyboard control. The A6 uses a standard equally-tempered keyboard, but its *linearity* – a term that refers to how its musical intervals are even from octave to octave and resemble "straight line" – can be significantly changed by the Track Gen such that all five octaves can be squeezed, expanded or even inverted. The Track Gen can be applied to many other modulators in order to modify their normal behavior.

Audio Mixing

The A6 provides several points in the sound path where audio levels are mixed. They are arranged on the front panel into three function groups: **PRE FILTER MIX**, **POST FILTER MIX** and **VOICE MIX**. The knobs in each group are used to set the **level** of a particular element of the sound indicated by their labels. For example, the **FILT 1 BP** knob in **POST FILTER MIX** controls the level of the band pass ("BP") output of **FILTER 1**.

To set levels, each knob controls the action of a VCA or Voltage Controlled Amplifier – a circuit that provides internal signal amplification. Much like the level knobs and faders on an audio mixer, you use a VCA's knob to control "how much" of a particular component of the Program. In most cases, the "how much" will be an audio level, but not always. VCAs provide signal amplification – also known as "amplitude level" or "more-or-less" control – to things like modulation amounts. The **ENV 1 AMNT** knob on **OSC 2** and the **ENV 2 AMOUNT** knobs in the VCFs are good examples of this.

The **PRE FILTER MIX** provides controls for blending both VCOs, the **RING MOD**, the **NOISE** generator and the three external Audio Inputs. As the name implies, these signal sources are mixed prior to being processed by the VCFs. On the A6's rear panel are 1/4" jacks labeled **FILTER AUDIO INPUTS**. These three jacks are used to input external audio signals for processing by the A6's filters.

The **POST FILTER MIX** controls the outputs of the two VCFs plus the unfiltered outputs of the VCOs' Sine waves and the Ring Modulator. This is the final mix that is sent to the output section (via the VCA controlled by Envelope 3).

Referring to our first flowchart in Chapter 3, the **VOICE MIX** is the unit's Output Section. Although the A6's main mixes are set in **PRE FILTER MIX** and **POST FILTER MIX**, this section controls the **final** output levels sent to the rear panel audio out jacks. At the bottom of the section the **LEVEL** knob regulates the output of **everything** in the Program currently being edited: the stereo **LEFT** and **RIGHT** and **AUX 1-2** jacks plus the eight stereo **VOICE OUTPUTS** and the stereo **HEADPHONES**. A switch controls whether the output of a program will go to the Main or Aux outputs (or to neither); but a voice is always output to its individual output as long as the **LEVEL knob** is up and the **VOICE MIX** switch is ON.

Last, the **MASTER VOLUME** knob on the left side of the front panel controls the overall output of the Main outs, Aux outs, and headphones, but not the individual Voice Outs. Unlike the **LEVEL** control, the position of the Volume control is not saved in memory as part of a Program or Mix.

Controllers

The A6 provides all the standard hardware controllers you'd expect in a keyboard synthesizer plus a few more. Most obvious is its 5-octave (C-to-C) semi-weighted keyboard that responds to velocity and aftertouch. It can be played normally with one Program across all keys, or can be split so that one Program plays from the lower range of keys and a second Program plays from the upper range. In fact, three-way and four-way (or more) splits are easy. In all cases, split points are user-assignable and programmable. Also, two or more Programs can be layered, and the balance of the Programs as well as any transposing are user-assignable and programmable.

The A6 features several keyboard performance modes under the **KBD MODE** heading. In addition to the A6's polyphonic (**POLY**) play mode, monophonic (**MONO**) and unison (**UNISON X**) voicings are also available along with a wide range of Portamento (**PORTA**) modes.

And where would we be without assignable Pitch and Modulation wheels? Notice that the controller wheels are not specifically labeled Pitch Bend and Vibrato. That's because you can define each wheel as you like it using the **ASSIGN** buttons. Some of us like the Mod wheel to be the one on the right, because in the days of hard-wiring controllers, most manufacturers just did it that way, and we got used to it. But you can assign Vibrato to be the one on the left, if you so desire. In fact, you can make **both** wheels Pitch or both Vibrato. Or make them do something else, like add/remove brightness, control volume level, you name it.

There are also back panel inputs for **FOOTSWITCHES AND PEDALS**. The A6's **PEDAL/CV** (commonly used for volume) and **SUSTAIN** pedal inputs allow the use of foot controllers for master volume control and sustain. A third input jack labeled **SWITCH** is ideally suited for footswitch control of patch changes. The electrical specifications for these switches and pedals are listed in Appendix C: Specifications.

That long strip of fabric along the top of the keyboard is the A6's Ribbon Controller. Normally assigned to the VCOs' frequency to create a pitch bend device, it can be assigned to countless other parts of the sound.

The rear-panel **CONTROL VOLTAGE INPUTS** labeled **OSCILLATOR** and **FILTER** are the classic control inputs from the early analog era. These inputs make controlling the VCOs and VCFs possible from external analog devices like an analog sequencer, guitar synth or wind controller.

The A6's Real-time **ARPEGGIATOR** takes held chords from the keyboard and/or incoming MIDI Notes and creates an *arpeggio* from the original chord. You can arpeggiate "up" (from the lowest note being played to the highest note), "down" (high to low), or up and down. You can also extend the range of the held notes to up to five octaves above the actual notes being played.

Another classic analog controller is the A6's 16-event, programmable **SEQUENCER** – a **step** sequencer that takes its design right out of the pages of analog genesis. The notes and filter settings are **programmed by hand** – not recorded like you'd expect from a digital or MIDI sequencer. There's a programmable sequence for each of the 128 Programs.

The **MASTER CLOCK** control sets the tempo for both the Arpeggiator and each Sequence, and can be slaved to received MIDI Timing Clock.

Effects

The digital effects built into the A6 employ the same state-of-the-art technology as the studio products Alesis is known for. The extensive list of effects is programmable not only for each Program but for each Mix as well. This gives you the freedom to set up effects sets that work well for a single Programs, then create other effects sets that are appropriate for split or layered Mixes. This design provides enormous flexibility when applying effects to the wide variety of sound textures possible with the A6.

An analog distortion section provides several levels of the classic "overdrive" sound essential to many synth sounds, with extensive control over how much distortion is added to a given Program or Mix.

Display

The 240 x 64 backlighted display – and its associated knobs and buttons – is your control panel for operating virtually all functions on the A6. It is both a text-based window where titled and numerical values are entered and a graphical workspace where A6 functions such as LFOs and Envelopes are pictured when edited.

The display area is where you edit programs and store them. It is where you assemble Mixes from the existing single Programs, and where you make your MIDI settings.

Master Controls

MASTER VOLUME: controls the final audio output level of the A6. Any pre- or post-mixing in a Program or relative levels set among the component Sound Programs in a Mix are not affected when adjusting the **MASTER VOLUME**.

MASTER TUNE: controls the overall tuning reference of the A6. This knob is used to tune the A6 to another instrument. Any VCO tunings, transpose amounts or relative tunings among the component Programs in a Mix are preserved when adjusting the **MASTER TUNE**.

AUTO TUNE: as a true analog synthesizer, the 32 VCOs and VCFs of the A6 are subject to slight amounts of tuning drift. Pressing this button twice retunes the VCOs and VCFs to standard pitch. A background tuning feature can be turned on or off as desired; normally it is left on.

TRANPOSE: this button transposes the A6 up or down over a two octave range. Using Middle C as your reference, press this button and use soft knob 1 to set the transpose amount. The A6 will be globally transposed by the new interval. As with **MASTER TUNE** and **AUTO TUNE**, any VCO tunings, transpose amounts or relative tunings among the component Programs in a Mix are preserved when transposing.

Rear Panel Inputs & Outputs

RAM EXPANSION CARD slot: accepts an Alesis PCMCIA Type I SRAM card for additional storage of both Programs and Mixes. A compatible RAM card can be formatted for storing several additional banks of your own Programs and Mixes, and can be used for data backup.

MIDI IN, OUT and **THRU** ports: these standard MIDI ports are used for communication between the A6 and other MIDI-compatible devices. A thorough discussion of the MIDI functions of the A6 can be found in Chapter 8.

FOOTSWITCHES AND PEDALS: see the discussion under the heading "Controllers" earlier in this section on page100.

CONTROL VOLTAGE INPUTS: see the discussion under the heading "Controllers" earlier

in this section on page 95.

FILTER AUDIO INPUTS: see the discussion under the heading “Audio Mixing” earlier in this section on page 95.

Audio

MAIN outputs: the **LEFT** and **RIGHT** 1/4” jacks provide the main stereo output signal for the A6. They are fed by the **MASTER VOLUME** control after the final voice mix is set by the **LEVEL** control in the **VOICE MIX** section.

AUX OUT: these two auxiliary audio outputs are mono 1/4” jacks that supplement the **MAIN** stereo outs. They are fed by the **MASTER VOLUME** control after the auxiliary voice mix is set by the **MAIN/AUX SWITCH** and **LEVEL** controls in the **VOICE MIX** section.

VOICE OUTPUTS: these eight stereo 1/4” jacks provide the means to mix each of the A6’s 16 Voices on its own mixer channel. These outputs are not affected by the **MASTER VOLUME** controls.

HEADPHONES: this stereo 1/4” jack is used with standard stereo headphones for private listening and/or monitoring of the A6. It is fed by the **MASTER VOLUME** control after the final mix is set by the **LEVEL** control in the **VOICE MIX** section.

Power

AC RECEPTACLE and **POWER** switch: the standard 3-prong recessed male receptacle accepts the standard grounded AC line cord. **A suitable cable for using the A6 in your geographical region was included in the carton.** Longer or shorter cables may be purchased at electronics or computer stores. Do not attempt to use another type of power cable and do not attempt to modify this receptacle or the cable itself. Doing so may cause serious injury or death. Please refer to the chapter at the beginning of this manual entitled **Important Safety Instructions**.

The **POWER** switch is used to turn the A6 on or off. As a precautionary measure, it is advised that you power on your A6 before you power on your audio system. This prevents any audio spikes that may be output from the A6 from damaging your amplifier or speaker system. By the same token, when shutting down your rig, turn off your amplifier first then the A6. This is a good practice to follow with all of your instruments and devices.

MIDI OVERVIEW

The A6 employs a comprehensive MIDI system for communicating with a wide variety of MIDI instruments and devices. Unlike many keyboard instruments, the A6 offers MIDI control that you wouldn’t normally expect from an instrument of its type. Of particular note, the A6 sends and receives MIDI Timing Clock. This System Real-Time Message is usually found only on time-based devices like a sequencer or a drum machine. Since the A6 has step sequencing and an arpeggiator, these clock-based features can control other rhythm-type units or be controlled from an external MIDI source.

The Andromeda is capable of sending and receiving on up to 16 MIDI channels simultaneously (but keep in mind that only 16 voices can sound at any one moment). Mix Mode is used for this kind of MIDI application. In Program Mode, the A6 sends and receives on a single MIDI channel at a time.

CHAPTER 5

PROGRAM FUNCTIONS PART 1: OSCILLATORS AND FILTERS

Up to this point in the manual, what we've covered so far will serve mainly as background material for the rest of the manual. But it is **important** background material, especially for A6 owners new to analog synthesis or analog veterans who've been away for awhile. For the rest of the manual, we'll be cross-referencing portions of the previous four Chapters as appropriate.

Before we dive into Program editing and creation, let's take a moment to review what progress we've made so far:

- Chapter 1 provides the info for setting up the A6.
- Chapter 2 is an expanded QuickStart guide: a working overview of the performance functions of the A6.
- Chapter 3 explains the roots of analog synthesis: what it is, how it works and how all of this began.
- Chapter 4 takes the info we provided in Chapter 3 and applies it to the A6. This Chapter also provides a list of A6 functions and brief descriptions.

Now we're ready to tackle programming the A6. The most intricate operations of the A6 lie in the area of creating new Programs or modifying existing ones. **As a prerequisite to actually creating Programs on the A6, we need to understand how the functions of the A6 operate.** Let's start by detailing the A6's primary sound sources, the Voltage Controlled Oscillators. We'll then cover the Filters, and the two primary modulation engines, the Envelopes and the Low Frequency Oscillators.

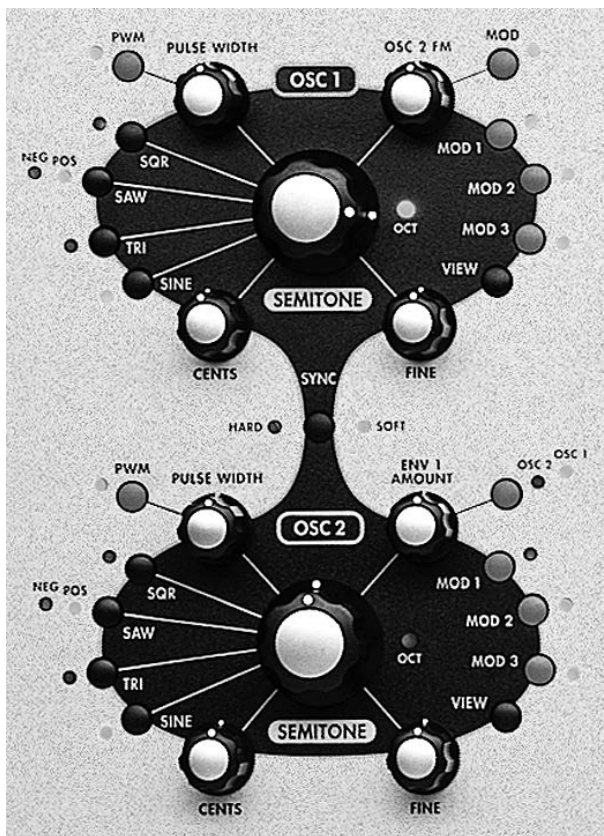

OSCILLATORS

The A6's Voltage Controlled Oscillators (VCOs), labeled on the front panel as **OSC 1** and **OSC 2**, are the primary sound sources in the A6. Although the A6 has a Noise Generator and inputs for external audio sources, you'll most likely be using the VCOs for the majority of sounds you create.

We've already covered much of the background and primary functions of the Voltage Controlled Oscillator in Chapters 3 and 4. In Chapter 3, we covered VCO waveforms – what they look like, what they sound like and how they are typically used to approximate familiar sounds. We also discussed the composition of a sound wave: the fundamental and its related harmonics and how filtering and envelope dynamics shape the sound.



Chapter 4 provided a brief functional overview of the oscillators. It also discussed how the VCOs (as well as other

A6 components) fit into the Program/Mix concept. With this as a foundation, we're now ready to explore the VCOs from a hands-on functional perspective.



OSCILLATOR PARAMETER DESCRIPTIONS

The following two tables summarize the Pages of parameters for the Andromeda's two oscillators. Notice that most of the parameters are present in both VCOs. Where there are differences, the manual will specify "OSC 1 Only" (FMMOD parameters) or "OSC 2 Only" (SYNC parameters) in the sub-title.

OSC 1 Parameters

| SOFT KNOB  | 1 | 2 | 3 | 4 | 5 | 6 | 7 | 8 |
|---|--|--------|--------|--------|---------------------------------------|--------|------|--------|
|  PAGE TAB | | | | | | | | |
| TUNE | SEMI | CENTS | FINE | 1PITCH | | | | |
| WAVE | SQUARE | WIDTH | LEVEL | SAW | TRI | SINE | | FILTFM |
| ENV1 | ENABLE | OFFSET | LEVEL | LIVE | Parameters for OSC 2. See next table. | | | |
| OSC2FM | LINFM | EXPFM | PWM | ASSIGN | OSC2FM | | | |
| NZEXT* | SOURCE | | LINFM1 | EXPFM1 | PWM1 | EXPFM2 | PWM2 | |
| | | | | | | | | |
| MODS | When this page is selected, the screen displays a summary table listing the five modulations for OSC 1 , and shows different page tabs allowing access to any of the modulations. A press of soft button 1 (<<BACK) from the MODS page will return to the TUNE page and parameters shown above. See page 111 for details. | | | | | | | |

OSC 2 Parameters

| SOFT KNOB  | 1 | 2 | 3 | 4 | 5 | 6 | 7 | 8 |
|---|---|-------|--------|--------|------|--------|--------|--------|
|  PAGE TAB | | | | | | | | |
| TUNE | SEMI | CENTS | FINE | 1PITCH | | | SYNC | |
| WAVE | SQUARE | WIDTH | LEVEL | SAW | TRI | SINE | | FILTFM |
| ENV1 | Parameters for OSC 1. See table above. | | | | LIVE | LEVEL | OFFSET | ENABLE |
| NZEXT* | SOURCE | | LINFM1 | EXPFM1 | PWM1 | EXPFM2 | PWM2 | |
| | | | | | | | | |
| MODS | When this page is selected, the screen displays a table listing the four modulations for OSC 2 just like OSC 1 above. See page 111 for details. | | | | | | | |

* **NOTE:** the NZEXT page is shared between the two oscillators—there aren't two external/noise sources.

TUNE Page Parameters: OSC 1 and OSC 2

Each oscillator has tuning knobs for coarse, fine and ultra-fine tuning control. These three controls have their neutral positions (where A-440 or Standard Pitch is achieved) at 12 o'clock. For each knob, its lowest frequency position is fully counter-clockwise. As you turn a knob clockwise, its frequency increases. As you turn the knob counter-clockwise, its pitch is lowered.

| DISPLAY PAGE | PANEL LABEL | PARAMETER DISPLAY | OPTIONS or RANGE | DESCRIPTION |
|--------------|-----------------------------|-------------------|----------------------------------|--|
| TUNE | OCT Panel LED | | | The OCT LED will light at each octave interval as the SEMITONE knob, described next, is used. |
| | SEMITONE | SEMI | - 60 ... 60 | Coarse tuning is accomplished with the SEMITONE knob. Turning this knob changes the VCO's frequency in precise semitone increments over a ten octave range: five octaves up or five octaves down from the 12 o'clock center position (A-440). |
| | CENTS | CENTS | - 100 ... 100 ± 1 semitone | For more precise tuning, use the CENTS knob or soft knob 2 below the display. The frequency set by the SEMITONE knob can be fine tuned in <i>cents</i> . One cent is 1/100 th of a semitone. |
| | FINE | FINE | - 100 ... 100 ± 1/10 semitone | Fine tuning is accomplished with the FINE knob or soft knob 3 below the display. The FINE parameter changes the oscillators' frequency in <i>millicents</i> . A millicent is 1/10 th of a cent, or 1/1000 th of a semitone. |
| | | 1PITCH | OFF, ON | If a VCO is being used as a modulation source, it may be necessary to keep its pitch at one particular frequency no matter what note or notes are being played. Turning this parameter ON will disable "keyboard tracking" of the selected VCO so that the same note is produced regardless of what keys (or MIDI notes) are played. More on this function in the next topic OSC 1 FM Parameters . |
| | SYNC (OSC 2 only) | SYNC | OFF, SOFT, HARD | An OSC 2 function only. See the expanded discussion of this parameter beginning on page 115. |

When the TUNE page is selected for either oscillator, note that the screen displays "A4 equals XXX.XX Hz." Key "A4" is the third "A" key counting up from the bottom (left side) of the keyboard. When the frequency shows 440.00 Hz, the A4 is tuned to standard pitch.

WAVE Page Parameters

| DISPLAY PAGE | PANEL LABEL | PARAMETER DISPLAY | OPTIONS or RANGE | DESCRIPTION |
|--------------|--|-------------------|---|---|
| WAVE | SQR Button + LED | SQUARE | OFF, ON | Turns the Square Wave on or off. |
| | PULSE WIDTH | WIDTH | 0 ... 100 | This parameter sets the width of the Square Wave. When the SQR parameter above is on, the graphic display depicting the Pulse Width will change when you turn the PULSE WIDTH control or soft knob 2. |
| | — | LEVEL | 0 ... 100 | Sets the output level of the SQR wave. Note that this is the only waveform that has a level control. The others are either on (full output) or off. |
| | SAW Button + LED | SAW Sawtooth | OFF, POS, NEG | This parameter turns the Sawtooth wave output of the selected VCO to POS (positive), NEG (negative) or off. |
| | TRI Button + LED | TRI Triangle | OFF, ON | This parameter turns the Triangle wave output of the selected VCO on or off. |
| | SINE Button + LED | SINE | OFF, ON | This parameter turns the Sine wave output of the selected VCO on or off. |
| — | FILTFM Filter Frequency Modulation Output | OFF, ON | This parameter turns the oscillator's send to the FM modulation of the filter section on or off. This Filter FM output goes to the Filter section's CV SRC parameter as the FILTFM source (see page 129). This is used if you want to use FM to modulate the filter with the oscillator output. | |

Selecting Waveforms

When editing an existing Program or creating a new one, one of the key issues in determining what the final program will sound like is what waveform is selected in each VCO. Both **OSC 1** and **OSC 2** have identical functions for producing waveforms so our discussion here covers both VCOs.

Selecting a waveform is as simple as pressing the button next to its panel label. Each VCO can have a different waveform and more than one waveform can be activated on each VCO. You can have all four waves on at the same time, for example.

The **SAW** and **SQR** (square wave, which is the pulse wave set to 50%) waveforms have a few controls not found on the **SINE** or **TRI** (triangle wave). Pressing the **SAW** button repeatedly toggles between **POS** (positive) and **NEG** (negative) sawtooth waves. Referring again to Chapter 3, a positive sawtooth corresponds to the Up Saw wave and a negative sawtooth corresponds to the Down Saw.

The **SQR** wave employs a **PULSE WIDTH** knob (duplicated on soft knob 2 when this page is being displayed) that varies its duty cycle. At its fully counter-clockwise position, the duty cycle is 0% producing that “nasal” sound we described in Chapter 3 on page 83. Turning the knob clockwise, the midpoint is 50%, producing a traditional square wave that we described as “hollow” sounding. As the knob is turned clockwise from the midpoint, the duty cycle begins to narrow again until the knob reaches its full clockwise position, producing a 100% pulse width, also “nasal” sounding but with different harmonics than the pulse widths below 50%.

VCO MODULATION

ENV 1 AMOUNT, OSC 2 FM and NZEXT

Of major importance in many synthesizer sounds is the ability to modulate the VCOs. The A6 provides each oscillator with several pre-routed and three custom modulations. We'll cover the pre-routed mods accessible from the **VIEW** page first: **ENV1 AMOUNT**, **OSC 2 FM** (found in Osc 1 only) and **NZEXT** (Noise/External).

| DISPLAY PAGE | PANEL LABEL | PARAMETER DISPLAY | OPTIONS or RANGE | DESCRIPTION |
|--------------|---------------------------------|-------------------|------------------|--|
| ENV1 | OSC 1, OSC 2 Button + 2 LEDs | ENABLE | OFF, ON | This parameter is used to turn the selected modulation on or off. |
| | | OFFSET | -100 ... +100 | This parameter sets the offset for the selected modulation level. |
| | ENV 1 AMOUNT | LEVEL | -100 ... +100 | This parameter sets the amount of modulation that will affect the selected VCO's frequency . Keep in mind that negative values invert the action of the selected source. For example, if Velocity is the source and a negative value for LEVEL is used, playing harder will lower the VCO's pitch. |
| | | LIVE | OFF, ON | This makes the front panel control ENV 1 AMOUNT active ("live") for either oscillator. The soft knobs still work but the LIVE parameter allows control from the single front panel knob. |

Using the ENV 1 AMOUNT Page

This page is displayed when you turn the **ENV 1 AMOUNT** knob on **OSC 2** or enter the page by pressing soft button **3** (ENV 1 tab) from either VCO's main display page. This may appear to be a little confusing at first, but just keep in mind that there's **one** ENV1 page that applies to both oscillators and three ways to get there: turn the **ENV 1 AMOUNT** knob, press soft button **3** from **OSC 1**'s main display page or press soft button **3** from **OSC 2**'s main display page.

So the first thing that you'll notice about this page is that it contains **ENV 1 AMOUNT** parameters for **both** VCOs. Because each VCO has its own set of parameters (the four on the left of the display are for **OSC 1**, four on the right are for **OSC 2**), you can set them independently.

The **ENV 1 AMOUNT** knob – shown on the ENV1 Page as the LEVEL parameter on the display – controls the amplitude of **ENV 1 (PITCH)** as a mod source modulating the **frequency** of **OSC 1**, **OSC 2** or both as destinations.

Pressing the button adjacent to the **ENV 1 AMOUNT** knob rotates among four possibilities: the first press routes **ENV 1** to **OSC 1** only, a second press routes **ENV 1** to **OSC 2** only, a third press activates both VCOs as **ENV 1** mod destinations, and a fourth press turns **ENV 1** off as a mod source to the VCOs. The LEDs indicate which VCO is selected as a destination.

Since there is only one front panel knob for **ENV 1** control, the **LIVE** parameter allows the selection of which oscillators were affected by turning the **ENV1 AMOUNT** knob. This way you can have one oscillator set to a constant value while the other would be controlled by the **ENV1 AMOUNT** knob. Or you can have the **ENV1 AMOUNT** knob control both oscillators. The soft knobs control the **ENV1 AMOUNT** settings regardless of the **LIVE** settings. The **LIVE** setting is only for the **ENV1 AMOUNT** knob on the front panel.

Once you have selected which VCO(s) to modulate by **ENV 1**, use the **ENV 1 (PITCH)** controls on the upper right-hand area of the front panel to adjust the characteristics of this envelope as it affects the frequency of **OSC 1**, **OSC 2** or both VCOs. The basics of envelope operation are provided in Chapter 6.

OSC 2 FM Parameters

Using a VCO as a Mod Source

The frequency of **OSC 1** can be modulated by **OSC 2**, hence the term “OSC 2 FM”, or “frequency modulation by Oscillator 2”. Using this modulation is a bit more involved than simply turning the **OSC 2 FM** knob clockwise to increase the amount of **OSC 2** modulating **OSC 1** although **amount** is the main parameter of FM.

What is “FM”?

The abbreviation for *frequency modulation*, FM can be easily confused with other forms of frequency modulation such as an LFO providing vibrato or trills by modulating the frequency of the VCOs. “FM”, however, has become synonymous with modulating an oscillator by another using one of several technologies that emerged during the 1930s.

As a modulation source, a VCO oscillates at a rate that **puts its frequency in the audible range**, as opposed to an LFO which typically oscillates at a slower rate that is below the range of pitched audio. Since a VCO can cover the entire audible frequency range (and then some: 20Hz to 22Khz), its effect as a modulation source for another oscillator is much different than of an LFO.

When you modulate a VCO by another VCO, the modulation rate is high enough to produce an entirely new set of harmonics called *sidebands*. The result of this type of modulation is often described as “buzzing” or “metallic”. Also significant in the modulating process is VCO tracking by the keyboard. When tracked by the keyboard, the frequency of the source VCO changes with each new key played, changing the characteristics of the sound.

There are two types of oscillator-generated FM in the A6, linear and exponential. **OSC 1** features both linear and exponential FM, **OSC 2** features exponential FM only.

| DISPLAY PAGE | PANEL LABEL | PARAMETER DISPLAY | OPTIONS or RANGE | DESCRIPTION |
|--------------|-------------|-------------------|------------------------|---|
| OSC2FM | OSC 2 FM | — | | This knob controls the amount of the FM type currently selected. There are three type of FM: Linear, Exponential and Pulse Width Modulation, described next. |
| | — | LINFM | 0 ... 100 | Linear FM causes the source VCO to modulate the destination VCO such that harmonics are added without shifting the pitch of the notes except at extreme amount settings. |
| | — | EXPFM | 0 ... 100 | Exponential FM, the type found on most synthesizers that have FM, causes OSC 1 to modulate OSC 2 such that harmonics are added by shifting the pitch of the notes. The audible result is clangorous, inharmonic tones. |
| | — | PWM | 0 ... 100 | PW Mod by FM causes the pulse width of OSC 1 to be modulated by OSC 2. |
| | — | ASSIGN | LINFM EXPFM PWID | Turning this soft knob selects the type of FM to be controlled by the OSC 2 FM knob: Linear, Exponential, Pulse Width or combinations: Linear + Expo, Linear + PW, Expo + PW, all three together or none. |

| DISPLAY PAGE | PANEL LABEL | PARAMETER DISPLAY | OPTIONS or RANGE | DESCRIPTION |
|---------------------|-------------|-------------------|------------------|---|
| OSC2FM Continued | — | OSC2FM | 0 ... 100 | This soft knob sets the amount of FM for the type(s) selected in the ASSIGN parameter above. If a combination of two or more types are assigned, notice that the amounts change together and by the same amount. Also notice that this soft knob has the same function as the OSC 2 FM knob in the OSC 1 section. |

Basic Operation

To get started, it's best if OSC 2 is not heard. You can always mix it in later, but for now you should turn the **OSC 2** knob in the **PRE FILTER MIX** all the way counter-clockwise. Also, be sure that **SYNC** is set of off.

Next, press the **VIEW** button for **OSC 1**, then press soft button 4 to select the **OSC2FM** page. Using soft knob 4 **ASSIGN**, select **LINEAR** as the FM type. If **EXPFM** and **PWM** aren't set to 0.00 already, zero them out using soft knobs 2 and 3 (or by pressing the ▲ and ▼ buttons simultaneously).

As mentioned earlier, the **OSC 2 FM** knob adjusts the amplitude (amount) of **OSC 2** modulating **OSC 1**. You can also use soft knob 5 for this purpose, or the individual soft knobs for each type of FM.

Play a key on the A6's keyboard. As you vary the amount, you will notice significant changes to the timbre of the sound.

Next, try experimenting with the frequency of **OSC 2**. First, vary the **SEMITONE** knob while playing the same key repeatedly and note the difference in timbre. When you arrive at a setting that sounds desirable, remember that you can fine-tune this frequency with the **CENTS** and **FINE** knobs.

While you're working with **OSC 2**'s tuning, try experimenting with the **1PITCH** parameter. Press **OSC 2**'s **VIEW** button, then press soft knob 1 to select the **TUNE** page if it's not already active. Use soft knob 4 to turn **1PITCH** on and off. Experiment with varying the amount of FM as well the tuning controls for **OSC 2**.

Notice that there's a **MOD** button adjacent to the **OSC 2 FM** knob. This indicates that the amount of **OSC 2** modulating **OSC 1** can itself be modulated by any of 79 modulation sources, which provides for some interesting possibilities.

To FM Modulate OSC 2 by OSC 1

To route **OSC 1** to FM **OSC 2**, press one of **OSC 2**'s **MOD** buttons and select **OFFSET ONLY** (the first parameter in the list) as the mod **SOURCE** with soft knob 1. As described on the next page, select **OSC 1** as the **NZEXT** source. Select **EXT -> EXP FM** (the last parameter in the list) as the **DEST** with soft knob 7 and experiment with different **OFFSET** levels.

To FM Modulate a Filter by an Oscillator

The filters can be modulated by the oscillators. In the **WAVE** page, use soft knob 8 to set **FILTFM** to **ON** for either or both Osc 1 and Osc 2. These sources will appear in the **Filters' CV SOURCE** parameters as **FILTFM**. If Filter 1's **CV IN** control is up, and either filter has **FILTFM** as its CV source, the filter will be modulated.

NZEXT Oscillator Modulation Parameters

Similar in principle to **OSC 2 FM**, NZEXT modulation allows you to use four of Andromeda's **audio** sources and use them as **modulation** sources. By incorporating these mod routes into the A6's modulation system, you now have the ability to use one of the synthesizer's three noise sources or Oscillator 1, which produce very high rates of modulation, as mod sources.

Note that, similar to the ENV1 modulation, the NZEXT modulation parameters for both VCOs are shown on a single page, with **OSC 1**'s parameters on the left and **OSC 2**'s on the right. There is a single **SOURCE** selection that applies to **both OSC 1** and **OSC 2**.

| DISPLAY PAGE | PANEL LABEL | PARAMETER DISPLAY | OPTIONS or RANGE | DESCRIPTION |
|-----------------------------|-------------|-------------------|-------------------------------------|--|
| NZEXT Noise/ External | | SOURCE | WHT NZ PNK NZ RED NZ OSC 1 | Selects the mod source: white (high frequency) noise, pink (mid frequency) noise, red (low frequency) noise or OSC 1 . Note that all five of the available destinations, described next, can be modulated at the same time by the selected source. |
| | | LINFM1 | 0 ... 100 | This parameter sets the amount of linear modulation to the frequency of OSC 1 . |
| | | EXPFM1 | 0 ... 100 | This parameter sets the amount of exponential modulation to the frequency of OSC 1 . |
| | | PWM1 | 0 ... 100 | This parameter sets the amount of linear modulation to the Pulse Width of OSC 1 . This modulation will only be heard if SQR is turned on in OSC 1 . |
| | | EXPFM2 | 0 ... 100 | This parameter sets the amount of exponential modulation to the frequency of OSC 2 . |
| | | PWM2 | 0 ... 100 | This parameter sets the amount of linear modulation to the Pulse Width of OSC 2 . This modulation will only be heard if SQR is turned on in OSC 2 . |

MOD 1, MOD 2 and MOD 3 Buttons and MODS Page

The **MOD 1, 2** and **3** buttons in the VCOs are used to display and edit the three custom mod routes for each VCO. A lighted LED adjacent to a **MOD** button indicates that a custom mod has been created for that VCO. Pressing a mod button shows its current modulation route in the display (if any) and displays the parameters that will allow you to create a custom modulation route.

The display also allows you access these three **MODs** at once, as well as PWM and FM. When any of a VCO's parameter pages are being displayed, pressing the **MODS** (soft button **8**) button displays a summary table of the current modulation routes for the currently selected VCO. (This grid, however, does not display the settings for **ENV 1 AMOUNT** modulation to the oscillators.) Reading from left to right, the table lists the modulation's name, the source, the amount, the offset and the destination. This is just a summary table so none of the soft knobs are active.

Soft buttons **3** through **7**, however, **are** active and allow you to display their respective modulations. Soft buttons **3**, **4** and **5** correspond to the **MOD 1**, **MOD 2** and **MOD 3** buttons in the VCO sections and display their respective pages when pressed.

Soft button **6** **PWMOD** corresponds to the **PWM** buttons in the VCO sections and soft button **7** **FMMOD** corresponds to the **MOD** button on the **OSC 2 FM** knob on **OSC 1**.

Tip: When using any of these buttons—either the dedicated buttons on the front panel or the soft buttons (mod tabs) under the display—pressing once displays the function’s page and a second press turns the function on (if it’s presently off) or turns it off (if it’s currently on).

| DISPLAY PAGE | PANEL LABEL | PARAMETER DISPLAY | OPTIONS or RANGE | DESCRIPTION |
|--------------|--------------------------------------|---|--|--|
| MOD1 | — | | | |
| MOD2 | — | | | |
| MOD3 | — | | | |
| | — | SOURCE | Any of the A6’s 79 modulation sources. See Appendix B. | Use soft knob 1 to scroll through the list of possible modulation sources. |
| | — | LEVEL | -100 ... +100 | This parameter sets the amount of modulation that will affect the selected destination using soft knob 3 . Keep in mind that negative values invert the action of the selected source. For example, if Velocity is the source and a negative value for LEVEL is used, playing harder will reduce the level of the destination. |
| | — | OFFSET | -100 ... +100 | Using soft knob 4 , this parameter sets the offset for the selected modulation level. |
| | MOD 1, 2 or 3 Button + LED | ENABLE | OFF, ON | This parameter is used to turn the selected modulation on or off. Use soft knob 5 or the panel buttons on the right side of the OSC 1 and OSC 2 sections. |
| | — | DEST Mod Destination | See table on next page. | Use soft knob 7 to scroll through the list of possible modulation destinations. The destinations are nine of the oscillator parameters described earlier in this Chapter. |
| PWMOD | PWM Button + LED | Uses same parameters as above with the exception of DEST which is, of course, the selected VCO’s Pulse Width as the only destination. See the following page for more information on PWMOD. | | |
| FMMOD | MOD Button + LED | Uses same parameters as above with the exception of DEST which provides three destinations only. See the following page for more information on FMMOD. | | |

MODULATION DESTINATIONS: VCOs

| PARAMETER DISPLAYED AS | DEFINITION |
|---------------------------------------|--|
| 1. FREQUENCY | The frequency of OSC 1 or OSC 2 . |
| 2. SQR WAVE LEVEL | The output level of the selected VCO's square wave. |
| 3. PULSE WIDTH | The pulse width of the selected VCO's square wave. |
| 4. OSC2 -> PWM (Oscillator 1 only) | The output of OSC 2 feeding into the pulse width modulation of OSC 1 . |
| 5. OSC2 -> LIN FM (Oscillator 1 only) | The output of OSC 2 feeding into the linear frequency modulation of OSC 1 . |
| 6. OSC2 -> EXP FM (Oscillator 1 only) | The output of OSC 2 feeding into the exponential frequency modulation of OSC 1 . |
| 7. EXT -> PWIDTH | The output of NZEXT (white, pink, red, or OSC 1) feeding into the pulse width of the selected VCO. |
| 8. EXT -> LINFM (Oscillator 1 only) | The output of NZEXT (white, pink, red, or OSC 1) feeding into the linear frequency modulation of the selected VCO. |
| 9. EXT -> EXPFM | The output of NZEXT (white, pink, red, or OSC 1) feeding into the exponential frequency modulation of the selected VCO. |

PWIDTH/PWM Parameters

Both VCOs provide for **PWM** or Pulse Width Modulation, shown as **PWIDTH** on the display. This means that the width setting of the pulse wave set by the **PULSE WIDTH** knob can be varied by a modulation source. This mod has been popular for years and has been used to re-create many well-known sounds ranging from lush string ensembles to thick synth pads.

When the **PWM** button is pressed on either VCO, the display shows the pulse width modulation parameters for that VCO. A VCO's pulse width is most often modulated by an LFO, but it can easily be modulated by an envelope, the keyboard (velocity, aftertouch or key track), the pitch bend and modulation wheels, pedals and ribbon controller, just to name a few of the 79 possible sources in the A6. See Appendix B for a complete list.

FMMOD Parameters

This is the page where the **OSC 2 FM** function (see page 109) is modulated. In other words, you can **modulate the amount of OSC 2 modulating OSC 1** with the parameters on this page. Referring to the table on the previous page, you have the same **SOURCE**, **LEVEL**, **OFFSET** and **ENABLE** parameters as the other mods. The difference is that **FMMOD** has the following three destinations:

MODULATION DESTINATIONS: FM MOD

| PARAMETER DISPLAYED AS | DEFINITION |
|------------------------|---|
| 1. OSC 2 -> LIN FM | The amount of OSC 2's linear FM modulating OSC 1 . |
| 2. OSC 2 -> EXP FM | The amount of OSC 2's exponential FM modulating OSC 1 . |
| 3. OSC 2 -> PWIDTH | The amount of OSC 2's linear FM modulating the Pulse Width of OSC 1 . |

SYNC Parameter: OSC 2 Only

Synchronizing OSC 1 with OSC 2

Even with the VCOs' fine tuning and ultra-fine tuning controls, it is impossible to tune the VCOs to **perfect** unison, especially across the entire range of the A6's keyboard or the wider range of MIDI Notes. There may be times when you need the tuning of two VCOs to be locked to each other. This is where **SYNC** is used.

SYNC forces the frequency of **OSC 2** to match the frequency of **OSC 1** by locking their waves' *phase* – when the waves begin their rise and fall during their periodic cycles. When two sound waves have their phases synchronized, their cycles begin at exactly the same instant and stay locked throughout the cycle.

| DISPLAY PAGE | PANEL LABEL | PARAMETER DISPLAY | OPTIONS or RANGE | DESCRIPTION |
|--------------|-------------------------------------|-------------------|------------------|---|
| TUNE | SYNC Button + Two LEDs | SYNC | OFF | Turns the synchronization of OSC 2 to OSC 1 off. Both VCOs oscillate independently. |
| | | | HARD | Turns HARD SYNC on. See description below. |
| | | | SOFT | Turns SOFT SYNC on. See description below. |

Pressing the **SYNC** button rotates among three synchronizing possibilities: the first press activates **HARD** sync, the second press activates **SOFT** sync, and the third press turns **SYNC** off. You can also use soft knob 7 when **OSC 2**'s TUNE page is displayed. The choices, in order, are – OFF –, SOFT and HARD.

HARD sync locks the phase relationship of **OSC 2**'s **fundamental wave** with that of **OSC 1**. **SOFT** sync locks the phase relationships of **OSC 2**'s **harmonics** with the harmonics of **OSC 1**. The audible difference between these two methods depends on the frequencies of the VCOs before sync is activated.

When tuned to approximately the same frequency, there's not much (if any) audible difference between hard and soft sync. What you'll experience is two VCOs tuned to perfect (well, for all intents and purposes) unison. There may be a noticeable increase in loudness – depending on which waveforms are selected – resulting from two waves being “right on top of each other” (more accurately called “in phase” with each other), and any beating from two oscillators in close frequency will disappear.

As the oscillators are tuned to wider intervals, the difference between **HARD** and **SOFT** sync (or no sync, for that matter) becomes more obvious. If you tune **OSC 2** up a fifth from **OSC 1** then turn **HARD** sync on, for example, a new set of harmonics are created resulting from two fundamental waves – with significantly different frequencies – being locked *in phase*: the waveforms start their cycles at the same time. Another set of harmonics is created when **SOFT** sync is used.

Since **OSC 1** is the reference, try tuning **OSC 1 up from OSC 2** and listen to the result of the slaved oscillator (**OSC 2**) being tuned **below** the reference oscillator (**OSC 1**). Listen to the difference between hard and soft sync in this situation. You might also want to experiment with octave intervals and dissonant intervals as well.

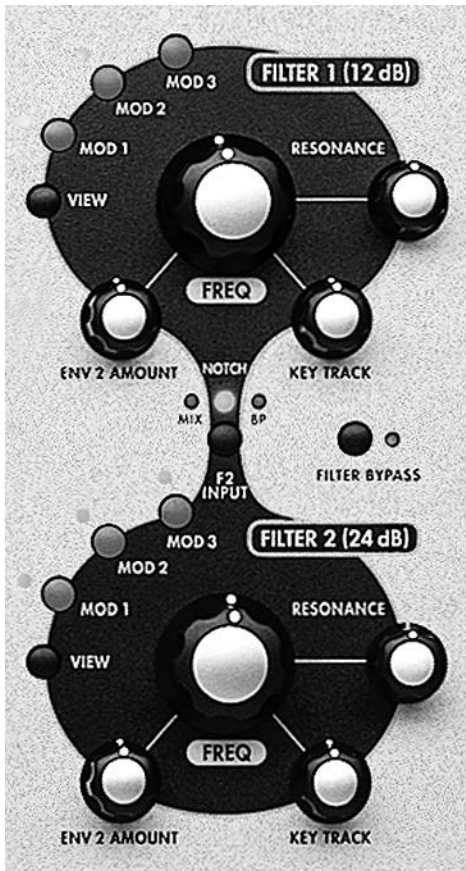

FILTERS

The A6's filters, labeled on the front panel as **FILTER 1** and **FILTER 2**, provide the harmonic control we introduced in Chapter 3. Unlike earlier analog synthesizers that utilized only one VCF, the A6 uses two filters that afford excellent flexibility in harmonic filtering. This accomplished by routing the output of **FILTER 1** into **FILTER 2** so that A6 is "filtering a filter".

FILTER 1 is a 2-pole multi-mode VCF which was designed to emulate the Oberheim® Synthesizer Expander Module™ (SEM) which was introduced in the mid 1970's. It has four fully adjustable modes: low pass, high pass, band pass and notch, just like the original SEM.

FILTER 2 is a 4-pole low pass filter which was designed to emulate the Moog® modular synthesizers introduced in the late 1960's.

WHAT FILTERS DO

The A6's audio sources – the VCOs, Noise Generator and external audio inputs – plus the output of each Voice's Ring Modulator all contain a certain quantity of harmonics. As you are editing a Program, one of the decisions you need to make is how bright (or muted) the sound will be. You also need to decide if the brightness level changes as the sound plays out, if

playing high notes or low notes affects the brightness, or if you want the brightness level to be modulated by, say, an LFO (or two) or controlled by the performance wheels. All of this is accomplished in the filter section.

Filters control the brightness of the sound (or lack of it) by electronically controlling the harmonic content of the audio source routed to them. A filter itself does nothing more than **set a range and an amount of frequencies that pass through it**. The **range** is determined by the settings of the **FILT LP**, **FILT HP** and the **FILT BP** knobs. The **amount** is determined by adjusting the **FREQ** knob on each filter.

This **FREQ** knob adjusts what is called the initial *cutoff frequency*. The position of the knob determines the point in the harmonic spectrum where unwanted harmonics start getting filtered out. The filter's filtering process **gradually** reduces the overtones until they reach a zero amplitude. This is called the filter's *slope* or *roll-off*.

The cutoff frequency can be modulated (and most often is) for a wide variety of useful and interesting results.

We'll cover more of what filters do – and how they do it – in greater detail later in this Chapter and in Chapters 6 and 7. But before we discuss methods and procedures, let's get some background on how filters are designed and how they work.

HOW FILTERS ARE DESIGNED

As important as the **amount** of audio frequencies that pass through the filter is the **type** of filtering that is employed. The basic filtering process depends, therefore, on the **mode** of the filter – whether it's low pass, high pass, band pass or notch filtering. Let's take a moment to describe these modes.

Filter Modes

A filter determines what harmonics pass through it by its mode. The four filter modes of the **FILTER 1** describe **how harmonics pass** (the keyword here is **pass**) through the filter:

Low Pass

As its name implies, low frequency harmonics (including the fundamental wave) are passed through the filter. This means that **high frequencies are filtered out**. **FILTER 1** provides low-pass filtering in addition to high-pass, band-pass and notch filtering. **FILTER 2** is low-pass only.

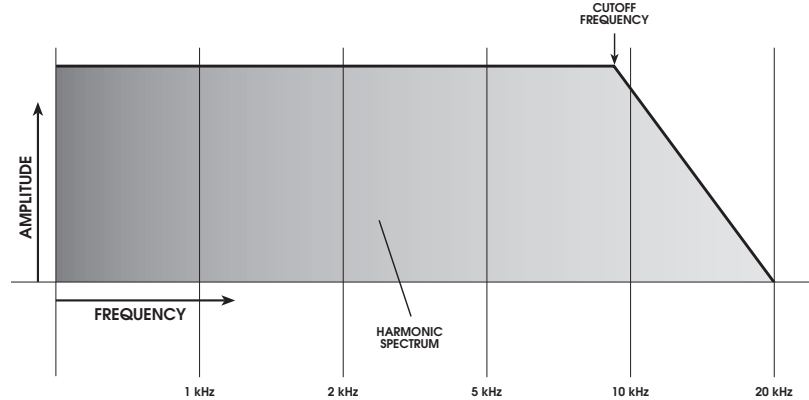

High Pass

High pass filtering is the opposite of low pass: high frequency harmonics are passed through the filter. This means that **low frequencies, including the fundamental wave, are filtered out** (if the frequency of the filter is above the fundamental). In essence, a high pass filter just passes some of the harmonics.

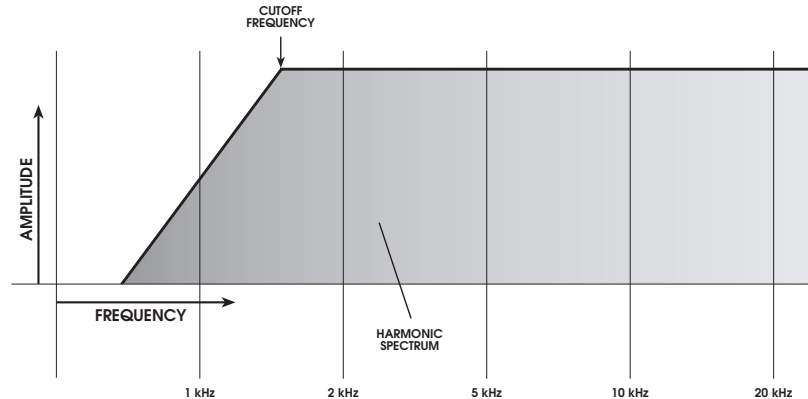

Band Pass

A section of the audio spectrum, called a “band of frequencies”, passes through the filter while **low** and **high frequencies are filtered out**. Turning the **FREQ** knob determines the center frequency of the band: harmonics just above and below this center frequency make up the band; harmonics to the extreme above and below are filtered out.

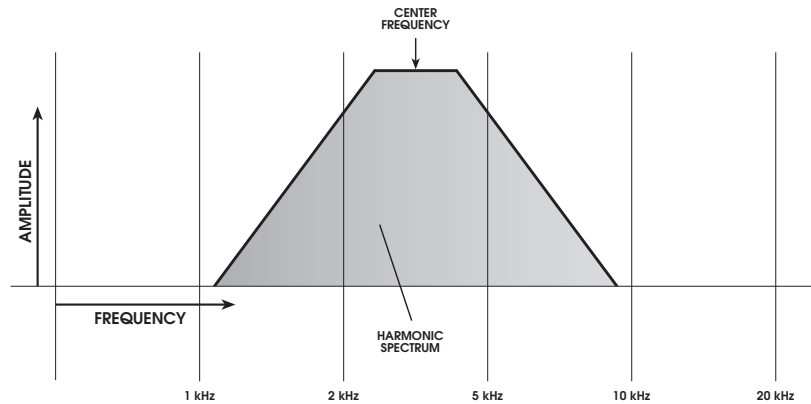

Notch

The **FILTER 1**'s notch filter is not a specific hardware filter like low, high or band pass filtering. Rather, notch filtering is created by combining the filtering characteristics of the low pass filter and the high pass filter. The notch of Filter 1 is **pre-set** by the A6, and is very narrow:

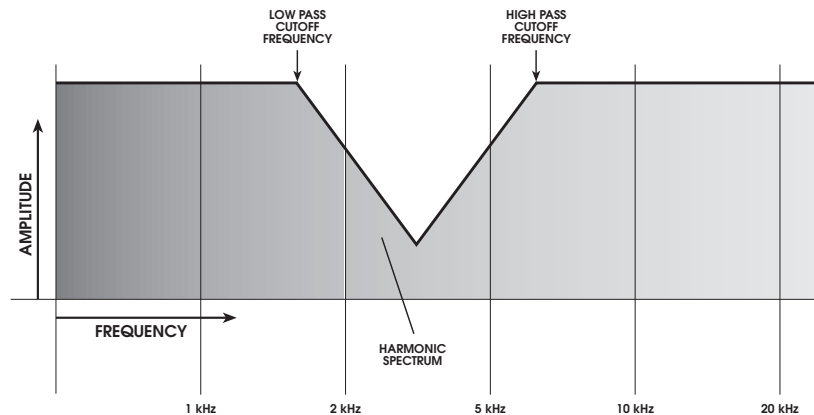

The opposite of band pass, notch filtering is sometimes referred to as “band-reject” filtering because it filters **out** a band of frequencies rather than passing them through. The A6 goes one further by actually providing true band-reject filtering by permitting you to invert the band pass filter, as covered in the next topic.

There is a way in the A6 to create a notch that has a **variable** width and depth. By selecting **MIX** as the input to **FILTER 2**, turning the **FILT1 LP** knob off (fully counter-clockwise) and turning the **FILT1 HP** knob up (fully clockwise), you are effectively running **FILTER 1** and **FILTER 2** in parallel, with Filter 1 passing the high end and Filter 2 passing the low end.

Since a notch is created by combining high and low pass filtering, you can adjust the frequency of Filter 1 and Filter 2. As long as the frequency of Filter 2 (the low-pass element) is lower than that of Filter 1 (the high-pass element), you'll have a notch. The closer the frequencies are to each other the narrower and shallower the notch. Conversely, the farther the frequencies are from each other the wider and deeper the notch as illustrated in the following graphs:

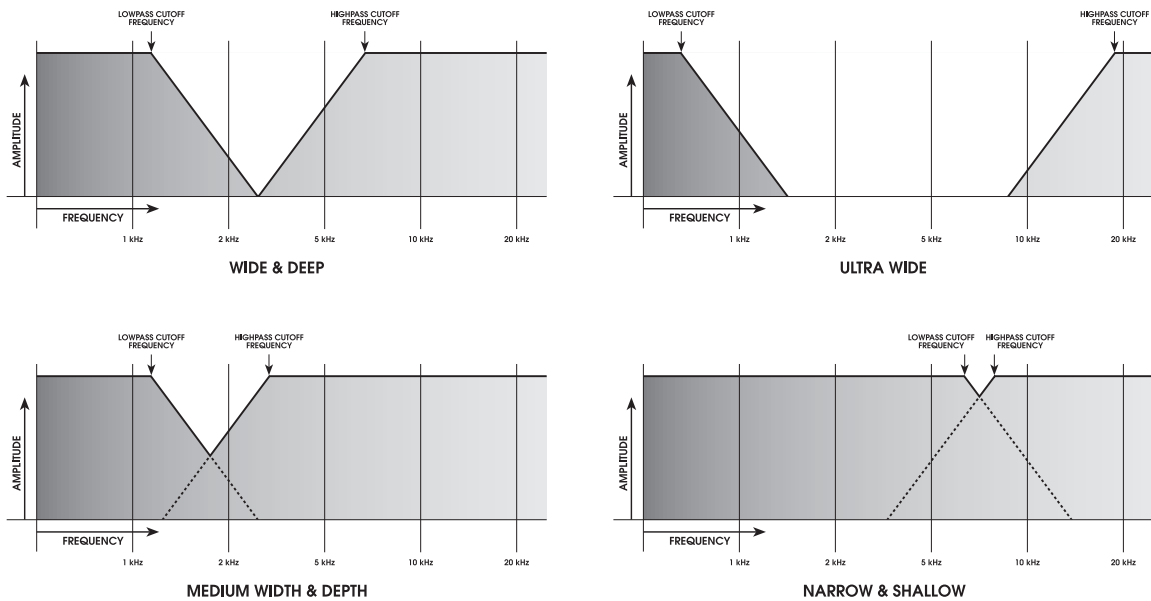

Notice that the notch is not symmetrical when this method is used. This is because the slopes of two filters are different: the 4-pole slope of **FILTER 2** is steeper than the 2-pole slope of **FILTER 1** (see "Slope", the next section).

Inverted Band Pass

By pressing the **BP INVERT** button, the band pass filter acts somewhat like a notch filter by inverting the slopes. The main difference is that an inverted band pass filter has a **fixed** width and depth; the notch, as illustrated above, has **variable** width and depth.

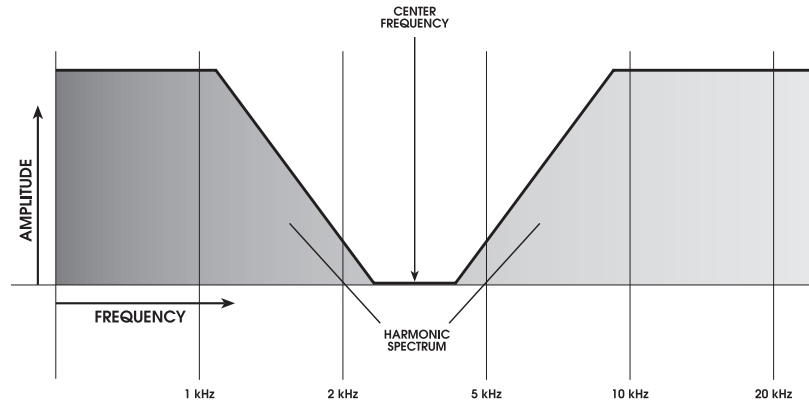

Slope

A filter's *slope* refers to the **rate** at which the frequencies are filtered out. Harmonics are not chopped off abruptly by the filter but are "rolled-off" or reduced in amplitude gradually. This gradual reduction in volume occurs at a rate expressed in "decibels per octave". Abbreviated "dB", the decibel is a standard of measuring amplitude. And since harmonics have frequency, they can be identified by musical intervals over a range of several octaves above the pitch of the fundamental.

The illustrations used so far in this section depict **FILTER 1**, which is a 2-pole filter that gradually reduces the harmonics' amplitude at a rate of 12dB per octave. **FILTER 2** is a 4-pole filter that rolls off the high end at a faster rate of 24dB per octave.

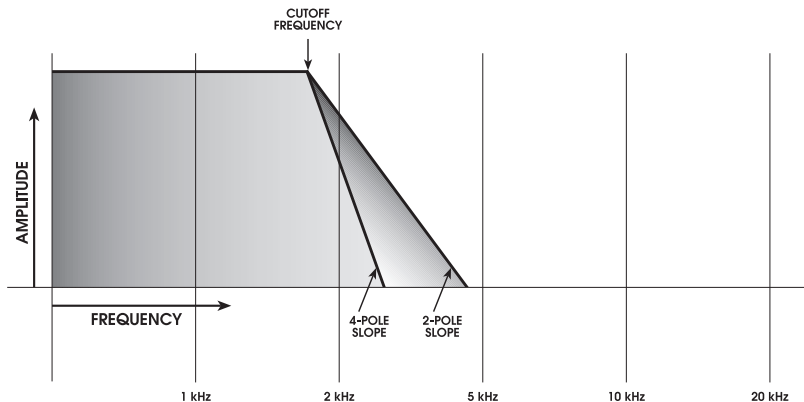

This graph illustrates how a 4-pole low pass filter reduces high-frequency harmonics faster than the 2-pole low pass. Notice the difference in harmonic filtering: at the same **FREQ** setting: the 4-pole filter removes more of the highs than the 2-pole.

Resonance

A characteristic of many acoustically-produced sounds is *resonance*. This occurs when a harmonic, whose amplitude is normally lower than that of the fundamental, rises in amplitude. In some cases, one or more harmonics are as loud as the fundamental. In fact, several instruments in the woodwind family – flute, oboe, bassoon for example – rely heavily on resonance for their sound.

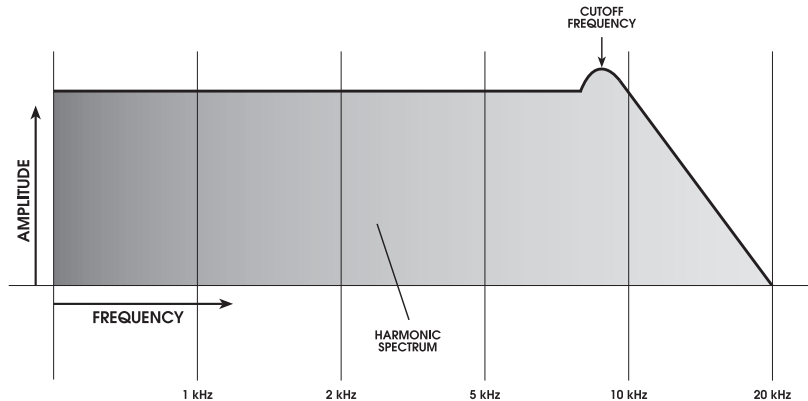

In an analog synthesizer, the **RESONANCE** control is used to raise the amplitude of the harmonic that is **nearest the cutoff frequency**. In the illustration above, a low pass

filter has its resonance boosted at 8kHz, producing a noticeable “hump” in waveform’s harmonic amplitude just before the cutoff slope begins. To our ears, increasing resonance produces a kind of “ringing” or “whistling” effect on the sound.

At its highest setting – fully clockwise – the resonance of **FILTER 2** breaks into oscillation and will output a sine wave near the same loudness as the VCOs. You can then “tune” this sine wave to a particular key. If **KEY TRACK** is active, you can play the resonance wave like a VCO. See the next topic. This is called “self-oscillation.”

Key Track

As you play the A6’s keyboard, the VCOs respond to pressed keys by playing the appropriate notes. When a key is pressed, the keyboard sends an electronic message that tells the two VCOs on a voice what **frequency** – or note – to play. Because the keyboard is *tracking* the VCOs, playing on the upper range of the keyboard plays high notes (high frequencies) and playing on the lower range of the keyboard plays low notes (low frequencies). This principle can be applied to the filters as well.

Unless instructed to do otherwise, the filters will output frequencies at a certain frequency as set by the **FREQ** knob. For most musical applications, this is not very useful because the lowest notes would have the right amount of harmonics but higher notes wouldn’t have enough and would sound dull as illustrated by the graph on the left. When the cutoff frequency is fixed, notice that all harmonics above the line have been filtered out.

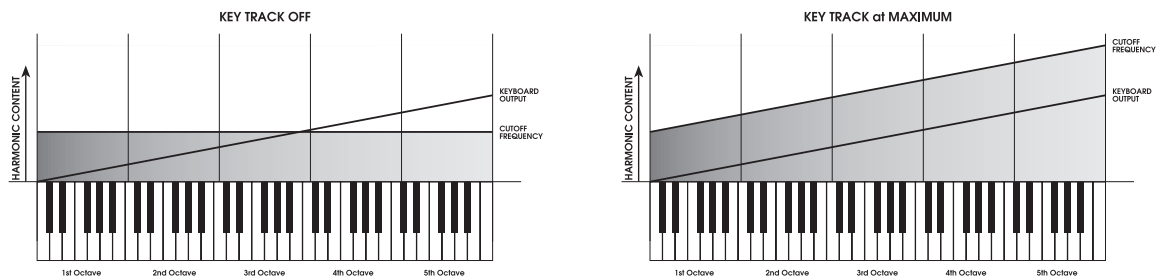

The **KEY TRACK** knob is used to set the amount of tracking effect that the A6’s keyboard (or received MIDI notes) has on the filters. At its midpoint setting of **+50.00** the filters will be tracked by the keyboard or MIDI by the same amount as the VCOs. At this setting, the VCOs and filters **track in parallel** so that high notes, low notes or anything in between will have the same **proportion** of harmonics as illustrated by the graph on the right. And, if the filter’s resonance is high enough to send it into oscillation, a **KEY TRACK** of 50.00 will make the oscillation play in the correct octave up and down the keyboard.

Modulation

Both filters have five modulation inputs. This means that the initial cutoff frequency, set by the **FREQ** knob, is a modulation destination that can be modulated by five modulation sources: **MOD 1**, **MOD 2** and **MOD 3** are customizable modulations (you pick the source) plus **KEY TRACK** and **ENV 2 AMOUNT** which sets the amplitude of Envelope 2 shaping the harmonic content.

HOW FILTERS WORK

In Chapter 3, we used a number of flowcharts to illustrate how audio, modulation and control signals flow through a generic synthesizer. Since the A6 is more advanced than our generic example, let's expand on this model with specific A6 components:

1. The A6's audio sources, before being routed to the filters, have their levels set in the **PRE FILTER MIX** section.

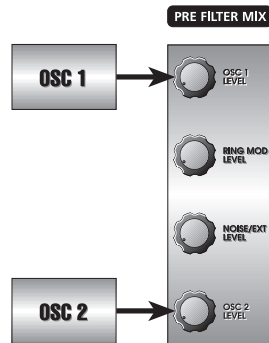

2. The output of the **PRE FILTER MIX** is routed first to **FILTER 1** where the initial frequency is set by the **FREQ** knob.

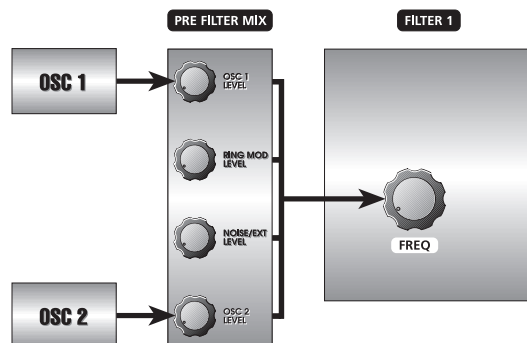

3. The three outputs of **FILTER 1** – its Low Pass signals, High Pass signals and Band Pass signals – are routed to the **POST FILTER MIX**.

Notice two things here: a.) All three types of filtering **are available at the same time**; you adjust the amount of each filter with its level control in the **POST FILTER MIX** section. (This is why **FILTER 1** is called a multimode filter.) b.) Notch filtering is produced by having both the Low Pass and High Pass levels above zero (with Band Pass off).

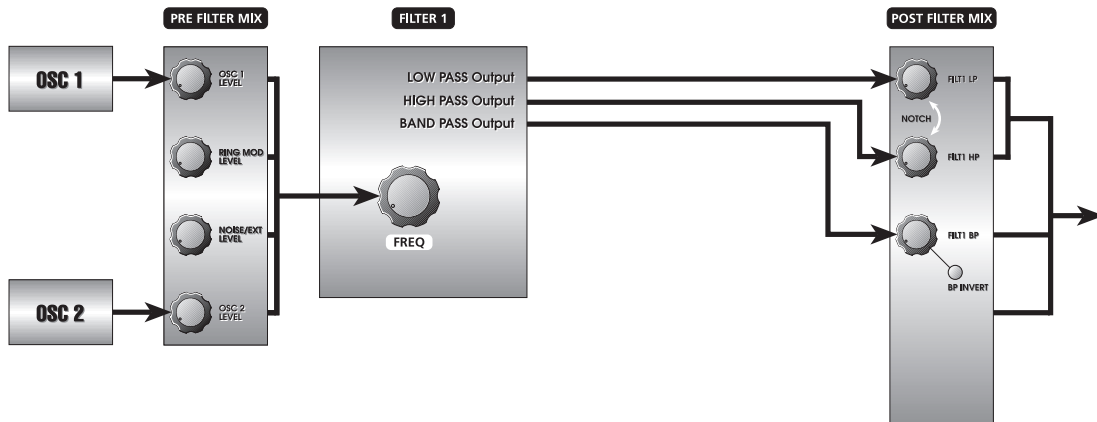

Tip: To use just one filter mode, turn the others **off** by turning their level knobs fully counter-clockwise.

- The composite output of the **PRE FILTER MIX**, the Band Pass output of **FILTER 1** or the Notch output of the of the **POST FILTER MIX** can be selected as the input of **FILTER 2** for additional 4-pole low pass filtering.

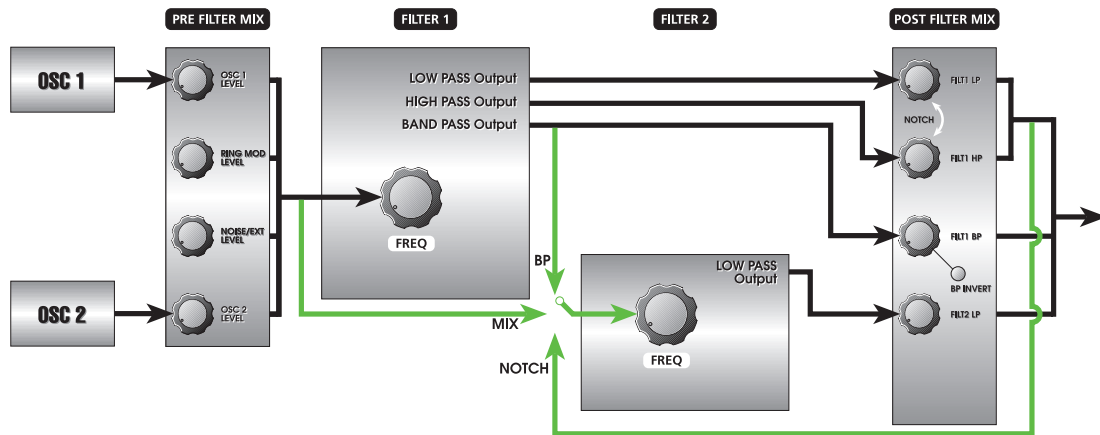

The **F2 INPUT** button is used to route these signals into **FILTER 2**. Pressing this button repeatedly switches between **MIX**, **NOTCH**, **BP**, or nothing as the input to **FILTER 2**:

- When **MIX** is selected, the source of **FILTER 2** is the **PRE FILTER MIX**—the oscillators, ring mod and Noise. **This is the same signal that goes to FILTER 1.** So when **MIX** is used, you have both a 2-pole multi-mode filter (**FILTER 1**) and a 4-pole low-pass filter (**FILTER 2**) **operating in parallel.**

This provides unprecedented capabilities in analog filtering. You now have the ability to route the same signal to two independent VCFs – with identical or different modulations.

- When **NOTCH** is selected, two things happen:
 - the source of **FILTER 2** is only the notch-filtered output of **FILTER 1** (which is the post-fader sum of Filter 1's low-pass and high-pass sections)
 - and those two volume controls of Filter 1 are disconnected from a direct connection to the VCA.

In other words, when **NOTCH** is used, you have two parts of a multi-mode filter (**FILTER 1**) and a 4-pole low-pass filter (**FILTER 2**) **connected in series.**

Note that you won't hear any output from **FILTER 2** unless either or both of Filter 1's **HIGH PASS** or **LOW PASS** knobs are up. Only the **BAND PASS** knob will send audio from Filter 1 directly to the VCA on its own.

In this case "notch" is a relative term, assuming that both the knobs are up. If the **HIGH PASS** knob is turned fully counter-clockwise, the notch effect is defeated and the low-pass output of **FILTER 1** is left as the signal. By the same token, if the **LOW PASS** knob is turned fully counter-clockwise instead, the notch effect is also defeated but the high-pass output of **FILTER 1** remains.

So, in essence, the **NOTCH** function can also be considered a low-pass or high-pass input from **FILTER 1**, depending on how the **LOW PASS** or **HIGH PASS** knobs are set.

- When **BP** is selected, only the band-pass output of **FILTER 1** is input to **FILTER 2**. Unlike **NOTCH** mode, however, the **FILTER 1 BAND PASS** volume control

does NOT have to be up to feed Filter 2. In fact, the band-pass output of Filter 1 can still feed the VCA directly if you turn the pot up.

To complete our signal path, the output of **FILTER 2** is then routed to the **POST FILTER MIX** where its level is set and routed to the **VOICE MIX** section for final output.

- Envelope shaping is accomplished by **ENV 2 (FILTER)**. Notice that the A6's front panel contains three **MOD** buttons on each filter (not depicted here) that permit you to route three additional modulations to the filters. We'll cover these other modulation paths in **Chapter 9: Custom Modulations**.

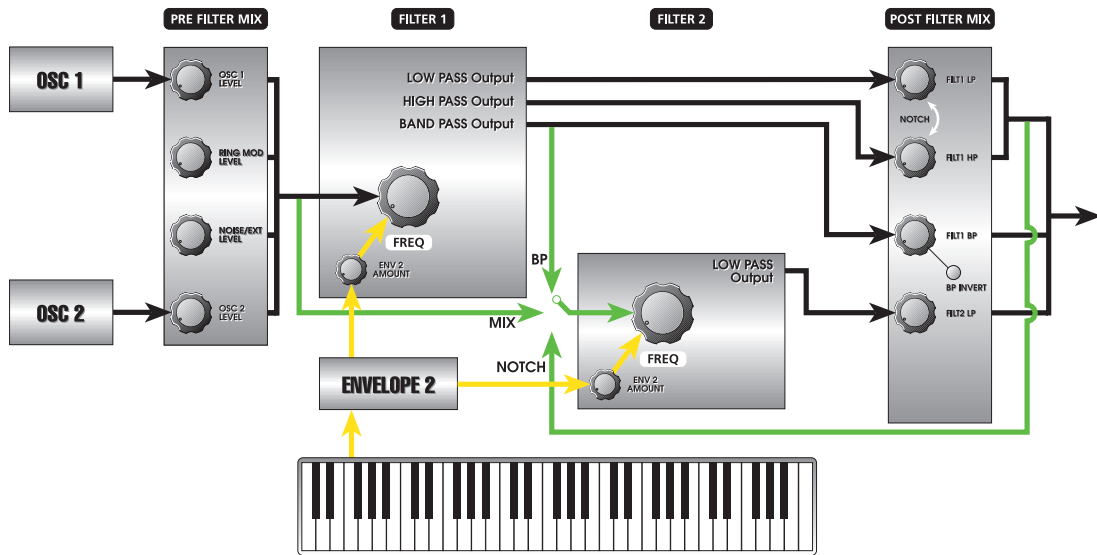

- RESONANCE** and **KEY TRACK** are introduced into the signal flow.

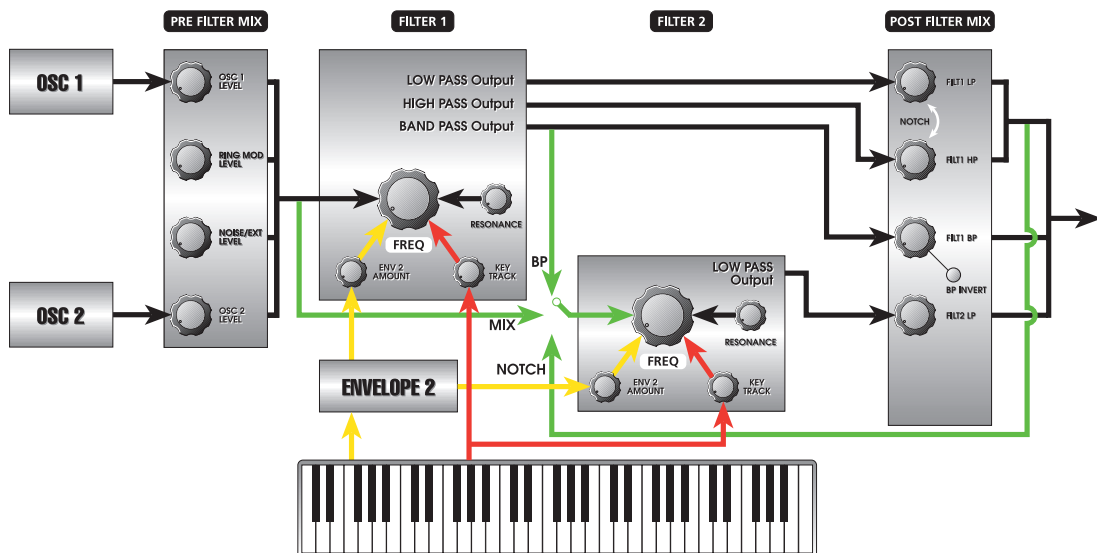

- The sine wave outputs of both **OSC 1** and **OSC 2**, plus the output of the **RING MOD** are routed directly to the **POST FILTER MIX** whose levels are controlled by the **PRE FILTER** knob. This signal path permits the mixing of these three signals into the A6's audio path **without** filtering.

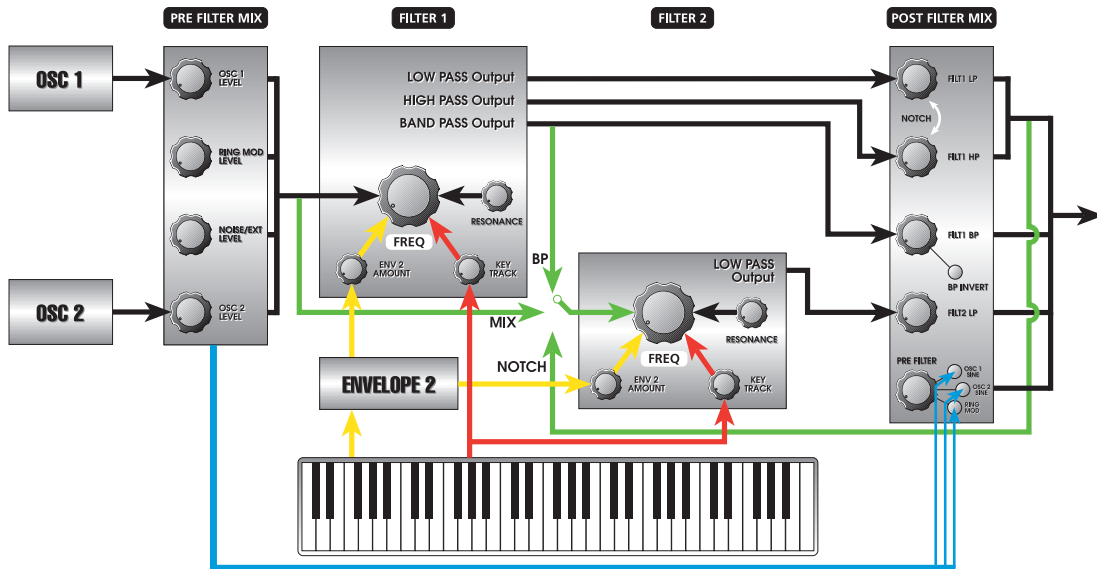

This direct signal flow from the sound generators, bypassing the filters provides three distinct advantages when editing Programs. First, since sine waves have no harmonics, filtering them has no effect on their tone—low **FREQ** settings only reduce their amplitude. Making it possible to let the sine waves bypass the filters avoids this situation.

Second, the sine waves available at this point in the mix **are in addition to** the waveforms selected in **OSC 1** and **OSC 2**. Mixing in unfiltered sine waves – effectively adding in unfiltered **fundamental** waveforms – with whatever waves are currently being output by the VCOs results in a thicker bottom end that would otherwise be impossible to achieve.

Third, there are also times when the output of the **RING MOD** sounds best when it is unfiltered. This direct audio path permits mixing an unfiltered signal from the Ring Modulator in with its filtered signal. The resulting blend of filtered and unfiltered **RING MOD** signals is a noticeably richer sound.

For envelope shaping of the loudness of these **PRE FILTER** signals, press the **MOD** button and assign an envelope at this point in the mix.

FILTER PARAMETER DESCRIPTIONS

Although **FILTER 1** and **FILTER 2** perform quite differently, their display parameters are similar in function if not in location.

Filter 1 Parameters

| SOFT KNOB → | 1 | 2 | 3 | 4 | 5 | 6 | 7 | 8 |
|-------------|--------|-----|-------|--------|--------|--------|-------|--------|
| ↓PAGE TAB | | | | | | | | |
| FILT 1 | FREQ | RES | ENV2 | OFFSET | KEYTRK | OFFSET | CV IN | CV SRC |
| | | | | | | | | |
| | | | | | | | | |
| MOD1 | SOURCE | | LEVEL | OFFSET | ENABLE | | DEST | |
| MOD2 | SOURCE | | LEVEL | OFFSET | ENABLE | | DEST | |
| MOD3 | SOURCE | | LEVEL | OFFSET | ENABLE | | DEST | |

Filter 2 Parameters

| SOFT KNOB → | 1 | 2 | 3 | 4 | 5 | 6 | 7 | 8 |
|-------------|--------|-----|-------|--------|--------|--------|--------|--------|
| ↓PAGE TAB | | | | | | | | |
| FILT 2 | FREQ | RES | INPUT | ENV2 | OFFSET | KEYTRK | OFFSET | CV SRC |
| | | | | | | | | |
| | | | | | | | | |
| MOD1 | SOURCE | | LEVEL | OFFSET | ENABLE | | DEST | |
| MOD2 | SOURCE | | LEVEL | OFFSET | ENABLE | | DEST | |
| MOD3 | SOURCE | | LEVEL | OFFSET | ENABLE | | DEST | |

Main FILTER Parameters

| DISPLAY PAGE | PANEL LABEL | PARAMETER DISPLAY | OPTIONS or RANGE | DESCRIPTION |
|------------------------|-----------------|-------------------|--|--|
| FILT 1 or FILT 2 | FILTER 1 (12dB) | | | |
| | FILTER 2 (24dB) | | | |
| | FREQ | FREQ Frequency | 0.0218 ... 22.3482 (Fil 1) 44.6960 (Fil 2) | This parameter is used to set the frequency of the selected filter (in kilohertz). |
| | RESONANCE | RES | 0 ... 100.00 | This parameter is used to set the amount of resonance of the selected filter. |
| FILT 2 (only) | F2 INPUT | INPUT | | Available on FILTER 2 only , this parameter allows you to select the input (the audio source) of FILTER 2 : |
| | | | OFF | FILTER 2 receives no input (but it can generate tones on its own when in full resonance). |
| | | | MIX | When this is selected, the output of PRE FILTER MIX is fed into FILTER 2 . When MIX is selected as the input, the A6's filters operate in parallel . This means that both filters are filtering the sound independently at the same time. Use the level knobs in POST FILTER MIX to "mix" the levels coming from both filters. To filter the A6's audio by FILTER 1 only, simply turn off FILTER 2 by turning the FILT2 LP knob fully counter-clockwise. To filter the A6's audio by FILTER 2 only, simply turn off FILTER 1 by turning the FILT1 LP , FILT1 HP and FILT1 BP knobs fully counter-clockwise. |
| | | | NOTCH | When selected, FILTER 2 will filter the output of FILTER 1's notch filter (Low Pass and High Pass, post-fader). The output of FILTER 1 LOW PASS and FILTER 1 HIGH PASS will be disconnected from feeding the VCA directly—their knobs feed only Filter 2. |
| | | | BP Band Pass | When selected, FILTER 2 will filter the output of FILTER 1's band pass filter. |

| DISPLAY PAGE | PANEL LABEL | PARAMETER DISPLAY | OPTIONS or RANGE | DESCRIPTION |
|--|--------------|-------------------|------------------------|---|
| FILT 1 or FILT 2 | ENV 2 AMOUNT | ENV2 | 0.00 ... 100.00 | This parameter is used to set the amount of Envelope 2 modulating the selected filter. |
| | | OFFSET | -100.00 ... +100.00 | This parameter sets the offset for ENV 2. |
| | KEY TRACK | KEYTRK | -100.00 ... +100.00 | This parameter is used to set the amount of filter tracking by the keyboard. At a setting of 50.00, the selected filter will be tracked by the keyboard at "1 volt-per-octave" which is the same amount as the VCOs. This means that the VCOs and the selected filter will be tracked by the keyboard in parallel. See page 121 for more details. |
| | | OFFSET | -127 ... +127 | This parameter sets the offset for KEYTRK. Unlike the other offset, it is quantized in semitones: if you want the filter to be an octave lower when it's tracking the keyboard, set this to -12. |
| FILT 1 (menu; affects both) | (none) | CV IN | 0.00 ... 100.00 | This parameter sets how much a control voltage (if one is plugged into the CV FILTER INPUT jack on the Andromeda's rear panel) will affect the filter frequency of both Filter 1 and Filter 2, if the filter's CV SRC is set to EXT IN. If CV SRC is set to OSC FM, this parameter sets the amount the filter will be modulated by the oscillator. |
| FILT 1 or FILT 2 | (none) | CV SRC | | This parameter allows you to select either an external input (typically from an external envelope generator) to modulate the filter, or to FM modulate the filter by OSC 1: |
| | | (OFF) | | If you turn Soft Knob 8 full counter-clockwise, so that neither of the following settings are highlighted, there will be no effect on the filter, regardless of the setting of the CV IN control. |
| | | EXT IN | | When EXT IN is in reverse type in the display, the filter may be controlled by a signal plugged into the CV FILTER INPUT jack on the Andromeda's rear panel. |
| | | FILTFM | | When selected, the filter may be FM modulated by the output of OSC 1 and/or OSC 2. For FILTFM to work, the oscillator's FILTFM output must be enabled (on the Oscillator's WAVE page /FILTFM parameter). The level of FM modulation is affected only by the CV IN parameter, not by any setting of the PRE FILTER MIX knobs. For more information, see "What is FM?" earlier in this chapter. |

MOD Parameters

| DISPLAY PAGE | PANEL LABEL | PARAMETER DISPLAY | OPTIONS or RANGE | DESCRIPTION |
|--------------|-------------|--|--|-------------|
| MOD1 | MOD 1 | | | |
| MOD2 | MOD 2 | | | |
| MOD3 | MOD 3 | | | |
| — | SOURCE | Any of the A6's 79 modulation sources. | Use soft knob 1 to scroll through the list of possible modulation sources. | |
| — | LEVEL | -100 ... +100 | This parameter sets the amount of modulation that will affect the selected destination. Keep in mind that negative values invert the action of the selected source. For example, if Velocity is the source and a negative value for LEVEL is used, playing harder will reduce the level of the destination. | |
| — | OFFSET | -100 ... +100 | This parameter sets the offset for the selected modulation. | |
| — | ENABLE | OFF, ON | This parameter is used to turn the selected MOD on or off. | |
| — | DEST | FREQUENCY, RESONANCE | Use soft knob 7 to select either FREQUENCY or RESONANCE as the modulation destination. | |

CHAPTER 6

PROGRAM FUNCTIONS PART 2: MODULATION AND ENVELOPES

MODULATION

Modulation is quite possibly the most-used operation in a synthesizer. It involves more of the routine day-to-day synth functions than most people are aware of. In fact, even the simplest of Programs has some kind of modulation programmed into it. Otherwise, you wouldn't be able to hear it.

This section will cover modulation principles and define a number of terms. Understanding the basics as they are laid out here will make a world of difference when you get to other topics that deal with specific modulations. Refer back to these pages if you need a review.

Also, the A6 incorporates what is called a *Modulation Matrix*. This technology allows you to route virtually any source to any destination, with few exceptions. Because this functionality is fairly wide in scope, we've devoted an entire Chapter to it, Chapter 9. The basics of modulation are covered right here.

BACKGROUND

What It Is

The simplest definition of *modulation* is "to change something by something else". It is modifying one component of a Program by another. Having said that, why would we want to use modulation?

Why We Use It

As we discovered in Chapter 3, natural sounds go through many subtle but significant changes as we are listening to them. Referring back to our example of vibrating piano strings, all kinds of modulation is going on. A synthesizer provides numerous types modulation to simulate the changes that an acoustic sound goes through. Therefore, it is essential that a synthesizer provide modulation capabilities if we are to approximate the subtleties and nuances of sounds we're familiar with.

But a synth is also capable of producing modulations above and beyond what is normally experienced with acoustically-produced sounds. Synthesizers have become famous for their ability to emit sounds that have never been heard before. Modulation has a whole lot to do with that.

MODULATION PRINCIPLES

Referring back to our definition of modulation as "changing something by something else", let's take a look at what this means.

When a musical sound is played, it can start out loud and fade out. It can also fade in and, at the peak of its loudness, end abruptly. It can fade in and then fade out, or just start loud and end loud. **This is volume modulation** or, more precisely, *amplitude* modulation. The loudness of the sound ("something") can be changed by a pedal, an envelope, an LFO, velocity or other sources ("something else").

Still using this example, as a sound is being played, it can start out bright and full and while it's fading out in volume it's also becoming less bright. Or as it fades in, it

gets brighter as it gets louder. **This is harmonic modulation** or, more precisely, *filter frequency* modulation. The brightness of the sound (“something”) can be changed by a pedal, an envelope, an LFO, velocity or other sources (“something else”).

The principle of “something/something else” is **the** key concept in understanding modulation. The “something” is called the *modulation destination* (or simply the destination). It is “what’s being modulated”.

The “something else” is called the *modulation source* (or simply the source). It is “what’s doing the modulating”.

Throughout the rest of this manual, we’ll be discussing modulation in terms of sources modulating destinations. This is called a *modulation path* or simply *mod path* and we’ll use this term in the documentation as well.

Common Modulations

To further illustrate the source/destination concept, this is a good time to take a look at some everyday modulations. Everything that is mentioned here will be covered in detail throughout the manual.

Keyboard, Mod Wheels and Pedals

Used as often as any modulation source, but rarely perceived as one, the keyboard is a legitimate source of modulation. Because a note played on the keyboard changes the frequency of the VCOs (the key word here is “changes”), the keyboard (and received MIDI Notes for that matter) can be counted among the mod sources in the A6. Another common keyboard mod destination is the Filters, since we often want the Filter to be more open on higher ranges of the keyboard, or even to track the keyboard exactly because it’s in self-oscillation.

However, the keyboard is most commonly recognized as a *controller* – a **mechanical** component that affects the sound, rather than a mod source that’s electronic or derived in the synth’s operating system. So we will refer to the keyboard in this manual as a controller rather than a modulation source *per se* as well as the mod wheels, pedals and ribbon controller.

Envelopes

Loudness and harmonic shaping, plus the amplitude-shaping of other sound elements, make the envelopes indispensable modulation sources for every Program in the A6.

Aside from the essential envelope-to-filter (**ENV 2**) and envelope-to-loudness (**ENV 3**) routings, envelopes are often used to affect VCO frequency (**ENV 1**), shape the amplitude of an LFO, or alter the shape of a VCO’s waveform.

LFOs

Low Frequency Oscillators are similar in design to the VCOs that are used as the primary sound source of an analog synthesizer. They utilize periodic waveforms like the VCOs (sine, triangle, sawtooth and pulse) and aperiodic waves (random and noise) but that’s where the similarity ends. An LFO is **not** intended to be used as an audio source but a modulation source and, as such, its output is not routed to any of the A6’s audio paths. Rather, an LFO is routed to other elements of the sound as a mod source, so while you can’t hear it directly, you can hear the effect of it on other elements of the sound.

The most common use of an LFO is for vibrato. In fact, the modulation wheel on the A6 controls the amplitude (amount) of an LFO that is routed to the frequency of the VCOs and often to the VCFs. Similarly, one or more LFOs are typically used in string ensemble Programs to simulate the animation of many stringed instruments playing together.

The LFO section of the A6 also contains an aperiodic mod source called sample-and-hold (**S & H** on the front panel). This classic analog mod, discussed in detail later, provides yet another random modulation typically based on a noise source rather than a periodic waveform.

Hardware and Software Modulation

What goes on under the A6's hood may not be of much interest or importance to most users, but we'd like to take a moment to talk about modulations that are hardware-based and mods that are generated by the A6's operating system, the software mods.

Hardware Mods

Some of the A6's modulation sources and modulation destinations exist as physical circuitry and are physically connected. These are called *hardware* or *hardwired modulations*. For example, Envelope 3 is connected to the output Voltage Controlled Amplifier; you don't have to program that.

Software Mods

In contrast to the hardware modulations, the remaining modulation sources and modulation destinations are generated by the A6's operating system. By nature, this makes them... *digital*. But not to worry: these mods in their raw form are output to a digital-to-analog converter so, in essence, they are analog modulations at the time they are put to use.

Appendix B: Table of Software Modulation Sources summarizes the software mod sources in the A6. The software mod **destinations** in the A6 are listed per function throughout this manual, as they are different for each type of function. For example, the mod destinations for the oscillators are completely different than those for the envelopes. We will provide destination lists wherever appropriate.

Default Modulation Paths

A key concept to understand when using modulation in the A6 is that many of the modulation paths in the A6 are already routed in the instrument's design. These are called *default modulation paths*. One of the reasons for including default mod paths is because these particular mods are used so often, pre-routing makes setting them up much easier: they're already "connected" so all you need to do is adjust values. Those of you familiar with mixing consoles and patchbays can think of default mod paths as being "normalled".

But you don't have to use them if you don't want to, and you can route any of the default modulation sources to a whole slew of other destinations. By the same token, default modulation destinations can be modulation by a host of other sources.



ENVELOPES

An envelope is used when you want to make changes in the level or the frequency of a destination **over a period of time** which can be mere fractions of a second – .001 seconds (or one thousandth of a second) – to several minutes or longer.

For level modulation, the changes an envelope makes to the destination is by **modifying its amplitude** (its amount or signal level) during a time period that you can set. **ENV 3**, which defaults to the A6's audio output amplitude (**AMP**), is a good example of this.*

For frequency modulation, an envelope's varying output levels can be used to change the current pitch of the VCOs (**ENV 1** defaults to the frequency of **OSC 1** and **OSC 2**) or the Program's harmonic content, also referred to as the "frequency" of the filters (**ENV 2** defaults to **FILTER 1 FREQ** and **FILTER 2 FREQ**).

ENVELOPE PROPERTIES

An envelope's output is often described as a *contour* or *shape*. The envelope's shape is determined by its level settings and time it takes to go from one level to the next. The rising and falling of an envelope's output levels during the time the envelope is running forms a "shape" so to speak which is then applied to a destination. The destination modulated by the envelope conforms to this shape: the envelope instructs it when to increase or decrease in level or frequency, by how much and for how long.

In Chapter 3 when we introduced the concept of the envelope, we used the example of sound dynamics when we described how an envelope shapes its destination. In our example, we used a synthesized sound's **loudness** (the destination) as the thing to be shaped by the envelope.

Using a sound's loudness again as our example, the envelope controlling it takes a certain amount of time for the sound to achieve maximum volume (or amplitude, which is set in the **ATTACK** time parameter), a certain amount of time for the sound to begin its initial fade (decreasing amplitude, set in the **DECAY 1** time parameter) to a second loudness level (**DECAY 2** level) and so forth until the sound has completely faded to silence.

On the other hand, the very same envelope can be used to shape an LFO: the amplitude in this case is the **intensity** of the LFO, where the envelope is used to fade the LFO in and out of the sound. Also, the very same envelope can be used to shape the waveforms in the VCOs: applied to a pulse wave, it can vary the wave's width from wide to narrow or narrow to wide, providing some interesting textures. The flexibility of the A6 becomes obvious when you know you can route an envelope to a long list of destinations. And also keep in mind that an envelope – or any of its parameters, for that matter – can be a destination: try modulating an envelope by an LFO, for example.

* Please note that **ENV 3** is *hardwired* (physically connected) to the voice's output stage and cannot be disconnected. While you can use **ENV 3** to modulate many other destinations, it is always routed to its voice's output.

ENVELOPE PARAMETER DESCRIPTIONS

The A6 has three 7-stage loop-able envelope generators per voice. The parameters of the envelopes are described on the following pages. Pressing a button or turning a knob on any of the three envelope areas displays that parameter. You can also press the **VIEW** button on the desired envelope and then use any of the display's soft knobs and buttons to work with a specific parameter as well as its dedicated panel controls.

| SOFT KNOB → | 1 | 2 | 3 | 4 | 5 | 6 | 7 | 8 |
|------------------------------|--------|--------|--------|--------|---------|--------|---------|--------------------|
| ↓ PAGE TAB | | | | | | | | |
| TIME | DELAY | ATTACK | D1TIME | D2TIME | R1TIME | R2TIME | SHAPE | |
| LEVEL | OFFSET | LEVEL | | D2LEVL | SUSTAIN | | R2LEVEL | POLAR ¹ |
| TRIG and RETRIG ² | SOURCE | | LEVEL | POLAR | | ENABLE | MODE | <PAGE> |
| | SOURCE | | LEVEL | POLAR | STAGE | ENABLE | MODE | |
| DYN | RESET | SUSPDL | KEYTRK | KTBASE | LVLTRK | VELMOD | RELMOD | |
| LOOP | START | END | COUNT | TYPE | SMOOTH | SSHAPE | BEAT | |
| MOD1 | SOURCE | | LEVEL | OFFSET | ENABLE | | DEST | |
| MOD2 | SOURCE | | LEVEL | OFFSET | ENABLE | | DEST | |
| MOD3 | SOURCE | | LEVEL | OFFSET | ENABLE | | DEST | |

¹ The POLAR parameter does not appear for ENV3.

² The TRIG and RETRIG parameters (except MODE) are only effective if MODE is set to MOD TRIG or MOD TRIG/GATE.

Normally, each of the A6's three envelope generators has a start level of 0, an end level of 0 and four *target levels* in between. Each target level is achieved by a time parameter as depicted in the illustration below.

Note the stages in the envelope's cycle that are marked **KEY PRESSED**, **KEY HELD DOWN**, and **KEY LET GO**. Normally, these actions "cue" the envelope: Key Pressed tells the envelope that a "Note On" has occurred: a key on the A6's keyboard has been played, a note has been played from the A6's Sequencer or Arpeggiator, or a MIDI

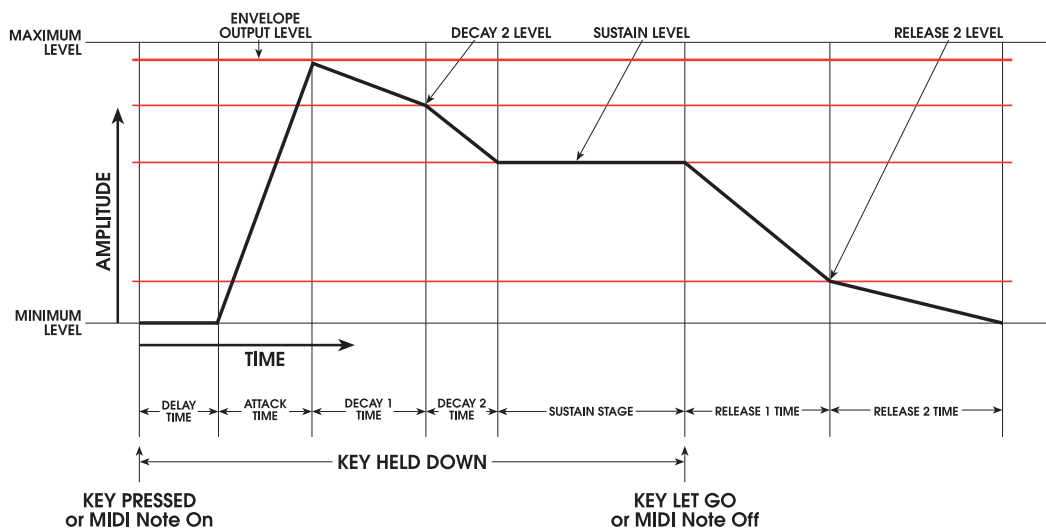

Note has been received. This message starts the Delay, Attack, Decay1 and Decay2 stages will complete in succession as long as a Key is Held Down. Since in this

example the Trigger Mode is set to NORM, the envelope's Sustain Level will also be maintained as long as the Key is Held Down. As soon as the Key is Let Go – a "Note Off" – the envelope continues according to the settings of the Release1 and Release2 parameters. This "normal" envelope cycle can be modified extensively, but we'll use this basic example as a good place to start.

ENV1 and **ENV2** are *bi-polar* envelopes meaning that each stage level setting has a user range of -100 through $+100$. **ENV3** is positive only because it is hardwired to the final output of the voice. Its stage level ranges, therefore, are 0 through $+100$.

ENV1 and **ENV2** being bi-polar can create unusual envelope shapes as shown in the following graphs. Note that the stage times are identical; only the levels have been changed.

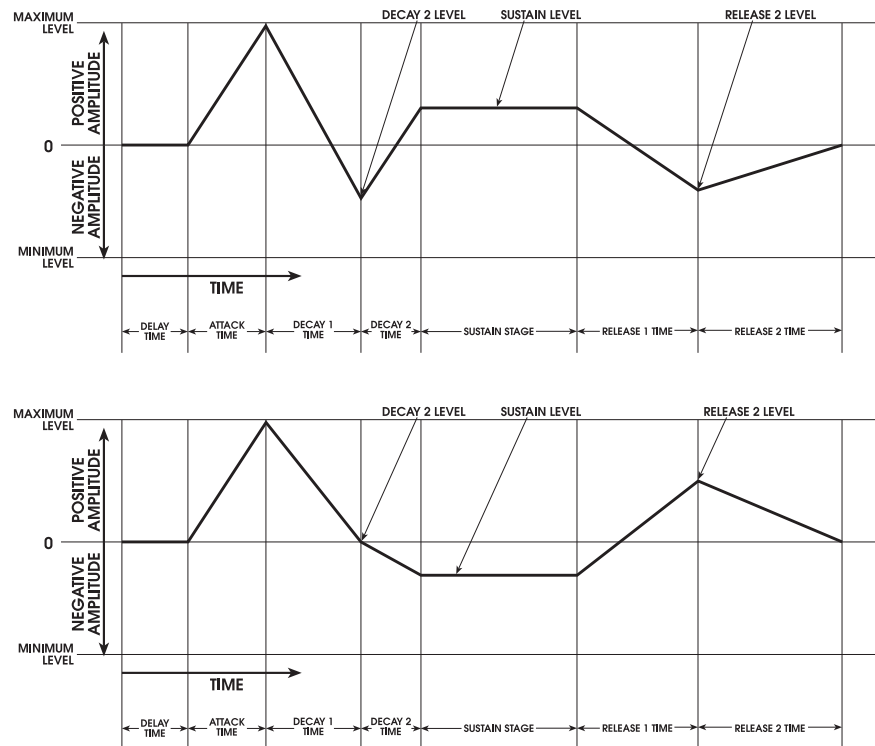

Decay 1, Decay 2, and Release 1 TIME stages can be bypassed by setting their TIME page parameters – D1TIME, D2TIME and R1TIME – to 0 . Sustain Level is bypassed by setting its level on the LEVEL page to 0 .

There are other ways to bypass stages, or go from one to another depending on when the note or sustain pedal is released using the TRIG MODE which we'll cover starting on page 144. But for now, let's continue with envelope basics assuming that the envelope mode is set to NORM1.

TIME Page Parameters

The TIME page is where the selected envelope's stage duration (TIME) and stage slope (SHAPE) parameters are adjusted.

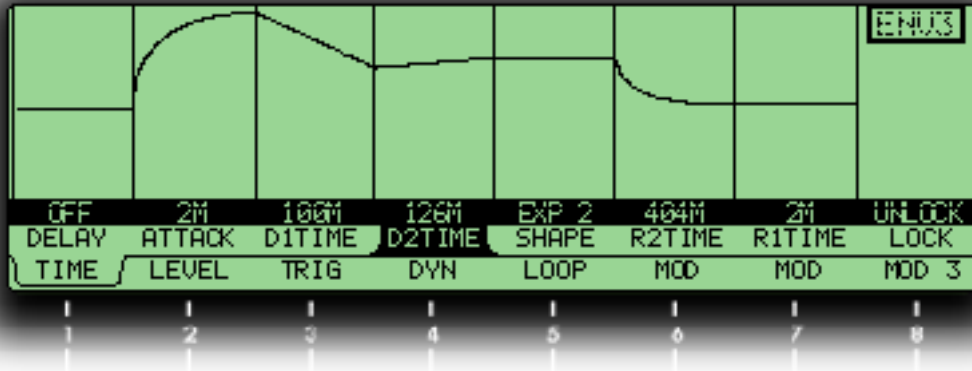

Tip: Although you can select any parameter simply by turning its corresponding soft knob, this action also changes the parameter's value which isn't always desirable. Sometimes you just want to review the current settings of the parameters on a page without changing anything.

On Envelope pages, you can select a parameter **without** changing its value by pressing its page's soft button. For these pages pressing a soft button once selects the page, pressing it again selects the parameter to the right of the active parameter in the Parameter Row. Repeated pressings cycle through all parameters from left to right. We call this handy little feature *tabbing*.

Parameters in the table below marked with a → are also mod destinations – they can be modulated by another source.

| DISPLAY PAGE | PANEL LABEL | PARAMETER DISPLAY | OPTIONS or RANGE | DESCRIPTION |
|--------------|-------------|------------------------|---------------------|--|
| TIME | → DELAY | DELAY Delay Time | OFF ... 131.05 S | From the moment a Note On occurs, this parameter sets the amount of time that elapses before the envelope begins its ATTACK stage. |
| | → ATTACK | ATTACK Attack Time | 2 M ... 131.05 S | The amount of time it takes the envelope to rise from minimum to maximum amplitude, from 2 milliseconds to 131.05 seconds. Note that Attack (and Release 2, next page) differs from the other envelope times in that a 2ms time minimum is required. |
| | f1 DECAY 1 | D1TIME Decay 1 Time | OFF ... 131.05 S | The amount of time it takes the envelope to decrease from its maximum amplitude to the D2 LEVEL. |
| | f1 DECAY 2 | D2TIME Decay 2 Time | OFF ... 131.05 S | The amount of time it takes the envelope to decrease from the D2 LEVEL to SUSTAIN level. The SUSTAIN level is the target level whether a note is being held or not. |

| DISPLAY PAGE | PANEL LABEL | PARAMETER DISPLAY | OPTIONS or RANGE | DESCRIPTION |
|--------------|-------------|-------------------|------------------|-------------|
|--------------|-------------|-------------------|------------------|-------------|

TIME
TIME
Parameters
(continued)

—

SHAPE

LINEAR
EXP 1, 2 & 3
LOG 1, 2 & 3
SCURV1 & 2

Designed after the CURVE function of the PORTA function, SHAPE refers to the *slope* (acceleration or deceleration attributes) of the envelope's Attack, Decay 1, Decay 2, Release 1 and Release 2 stages.

This parameter is **active at all times** for all time parameters except DELAY. To select a particular slope for a time parameter, select the parameter by tabbing with soft button 1, then use soft knob 5 to select the desired slope. The display will show an envelope graphic that will depict the slope selected for each stage.

See the **SHAPE** topic on the following page for a detailed description of the A6's stage slopes.

| | | | |
|-------------|--------------------------|---------------------|---|
| → RELEASE 1 | R1TIME Release 1 Time | OFF ... 131.05 S | The amount of time it takes the envelope to decrease from the SUSTAIN LEVEL to the RELEASE 2 LEVEL ; this is the envelope stage entered when a Note Off occurs. |
| <hr/> | | | |
| → RELEASE 2 | R2TIME Release 2 Time | 2 M ... 131.05 S | The amount of time it takes the envelope to decrease from the RELEASE 2 LEVEL to zero, from 2 milliseconds to 131.05 seconds. Note that Release 2 (and also Attack, previous page) differs from the other envelope times in that a 2ms time minimum is required. |

Important Note: If R2TIME is set to its maximum value, the envelope will enter into “infinite release”. This means that when the envelope reaches this stage, it will hold at its R2LEVEL (see page 141) indefinitely until you change to another Program or Mix, or turn the A6 off.

To alert you that R2TIME has been set to its maximum, the **HOLD** LED on the front panel for that envelope will light.

SHAPE: Selecting the Stage Slope

Each **time** parameter of an envelope (except Delay) has a user-selectable property called *slope*. This term refers to how the attack, decay and release stages *accelerate* (speed up) or *decelerate* (slow down) as each stage approaches its target level.

ENVELOPE SLOPES

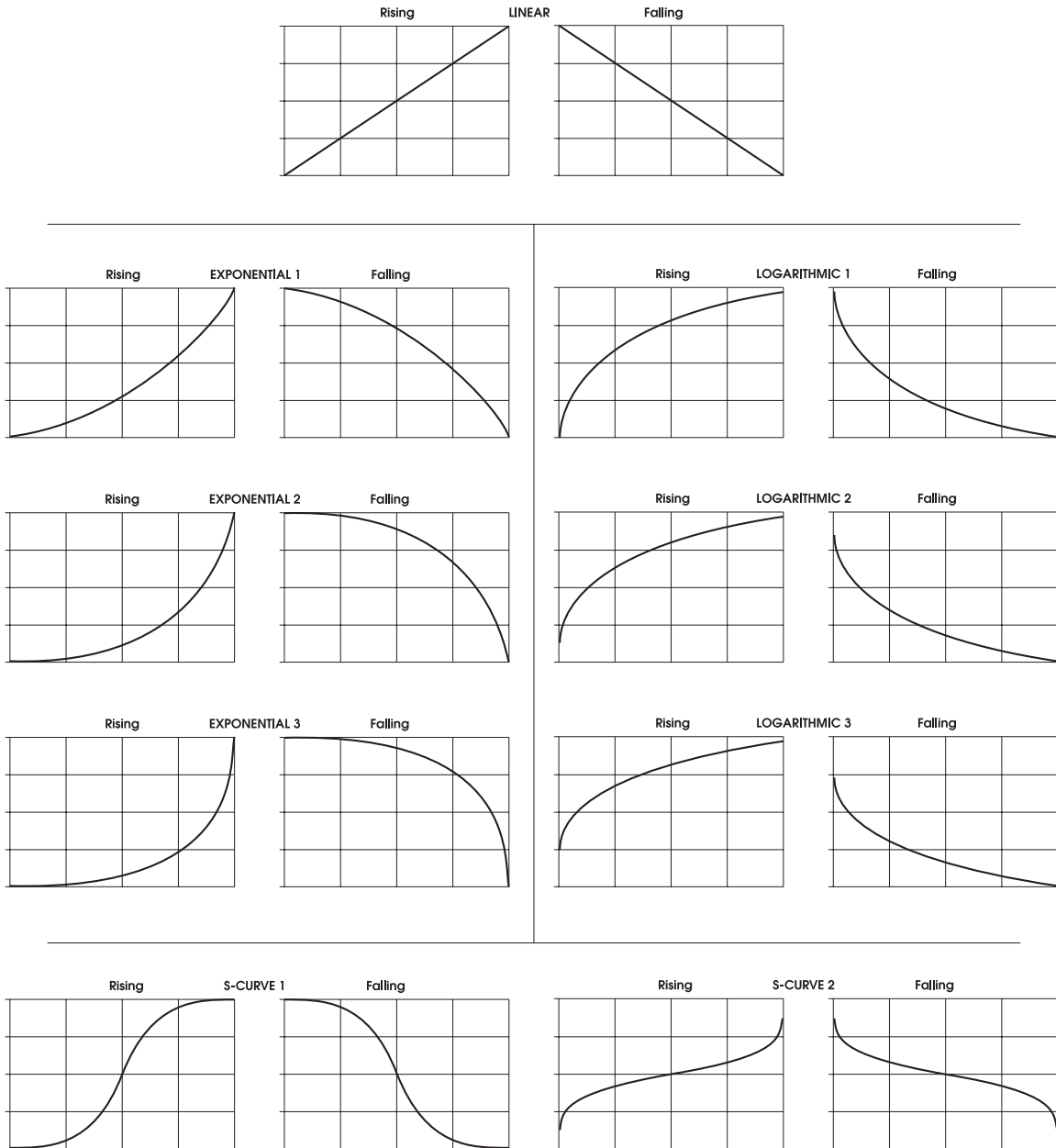

When a time stage parameter is selected, its current slope appears in the far right side of the display. Use Soft Knob 7 to make your selection:

- A **LINEAR** slope means that the time settings do **not** accelerate (or decelerate) as the stage progresses towards its target level. In the illustration above, notice that the linear slope is depicted as a straight line (from where we get the term “linear”). The stage doesn’t speed up or slow down in its duration but keeps an even rate of change.

- An EXP (exponential) slope, however, **accelerates** towards the target level: it starts out slow then speeds up as it gets closer to its target level. Rather than a straight line, it is represented by a curve. One of three exponential curves can be selected:

EXP 1 less steep than EXP 2
EXP 2 standard exponential curve
EXP 3 steeper than EXP 2

- In contrast, the LOG (logarithmic) slope **decelerates** towards the target level: it starts out fast then slows down as it reaches its target level. It is represented by a curve that is the opposite of the exponent. One of three logarithmic curves can be selected:

LOG 1 less steep than LOG 2
LOG 2 standard logarithmic curve, pictured above
LOG 3 steeper than LOG 2

- The SCURV (“S”-Curve) **combines the slopes** of EXP 2 and LOG 2. One of two S-curves can be selected:

SCURV1 The rising-amplitude of S-Curve 1 is characterized by acceleration during the first half of its stage using EXP 2, then decelerates during the last half using LOG 2. This is commonly known as a *forward progression s-curve*.

The falling-amplitude of S-Curve 1 is the opposite of its rising-amp: the stage decelerates during the first half using LOG 2, then accelerates during the last half using EXP 2.

SCURV2 The opposite of S-Curve 1 – commonly referred to as a *reverse progression s-curve* – the rising-amplitude of S-Curve 2 decelerates during the first half using LOG 2, then accelerates during the last half using EXP 2.

The falling-amplitude of S-Curve 2 accelerates during the first half using EXP 2, then decelerates during the last half using LOG 2.

Tip: The Attack, Decay and Release stages **can have different slopes**. You can mix and match slopes any way you want within the same envelope.

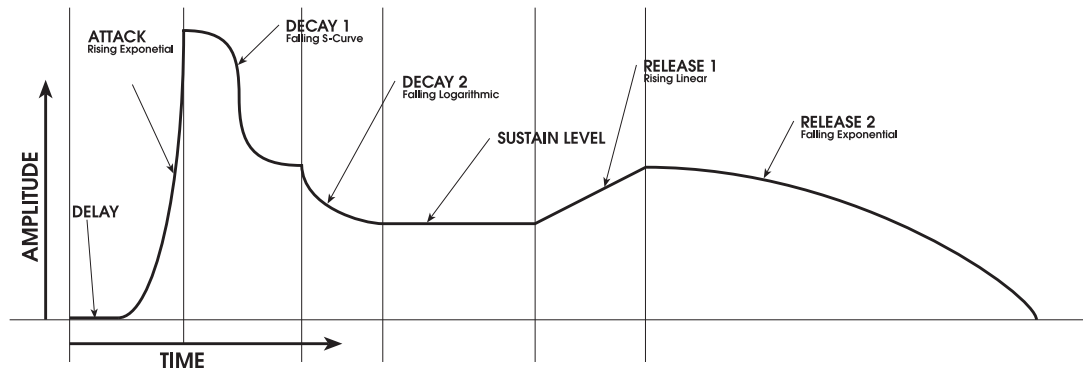

LEVEL Page Parameters

This page of parameters is where the four levels of the envelope are set. Notice that you can use a negative value for any or all of the levels in Envelopes 1 and 2.

| DISPLAY PAGE | PANEL LABEL | PARAMETER DISPLAY | OPTIONS or RANGE | DESCRIPTION |
|--------------|-----------------|----------------------------|---|---|
| LEVEL | — | OFFSET | -100 ... +100 | This parameter sets the fine adjustment of the output LEVEL parameter, described next. |
| | — | LEVEL Output Level | 0 ... 100 | This parameter sets the overall output level of the envelope. This is also the target level of the ATTACK stage. |
| | D2 LEVEL | D2LEVEL Decay 2 Level | -100 ... +100 ENV1 & ENV2 only 0 ... 100 ENV3 only | The target level for the DECAY 1 slope; at this point the DECAY 2 time begins. |
| | SUSTAIN | SUSTAIN Sustain Level | -100 ... +100 ENV1 & ENV2 only 0 ... 100 ENV3 only | The target level for the DECAY 2 slope; in typical cases this is the “hold” level during a <i>sustain situation</i> : a key on the A6’s keyboard is being held down, the A6 is waiting for a MIDI Note Off command or the end of the GATE from the built-in Sequencer or Arpeggiator. |
| | R2 LEVEL | R2LEVEL Release 2 Level | -100 ... +100 ENV1 & ENV2 only 0 ... 100 ENV3 only | The target level for the RELEASE 1 slope; at this point the RELEASE 2 time begins. |
| | — | POLAR | POSWAV NEGWAV | This parameter allows you to select between a normal or “positive” (POSWAV) or inverted (NEGWAV) envelope. When inverted, the envelope is turned “upside down”: the envelope begins at maximum level and the Attack stage transitions to zero . The Release 2 stage transitions the level back to maximum. This parameter is available for Envelopes 1 and 2 only. Envelope 3 is positive only: inverting ENV 3 would cause it to release indefinitely at maximum level, with nothing to stop it. |

TRIG and RETRIG Pages Parameters

The envelope’s Time and Level parameters determine its **shape** or **contour**. As important as an envelope’s shape is **when** it begins its cycle and **how** it plays through the cycle. This is where the TRIG and RETRIG pages come in.

An envelope starts its cycle when it receives a trigger. The most typical and often-used trigger source is the keyboard: a key or keys played on the keyboard instruct the envelopes to start their cycles. By the same token, incoming MIDI notes are also used to trigger the envelopes, the A6’s Sequencer and Arpeggiator, and a slew of other trig sources we’ll get into shortly.

The TRIG and RETRIG pages let you determine:

- where the trigger comes from – the keyboard/MIDI, another envelope, an LFO, the Sequencer and so forth
- under what conditions an envelope responds to a received trigger
- **how** an envelope proceeds through its cycle once a trigger is received
- if an envelope is re-triggered and how responds

So this page not only lets you determine if and when an envelope gets a trigger but also what is does after the trigger starts the envelope. Looping would normally fall into this category but because it has a rather large set of parameters, LOOP has its own page of parameters described on page 160.

The following table provides a summary overview of the TRIG page parameters. A detailed discussion of the MODE types starts right after the table.

| DISPLAY PAGE | PANEL LABEL | PARAMETER DISPLAY | OPTIONS or RANGE | DESCRIPTION |
|--------------|-------------|-------------------|--|---|
| TRIG | TRIGGER | ENABLE | OFF, ON | The TRIGGER button on each envelope, or soft knob 6 under each envelope page display, turns the trigger for the selected envelope on or off. |
| | — | SOURCE | Any of the A6’s 71 modulation sources. See Appendix B. | <p>This parameter allows you to select an “input” that triggers the envelope. Any of the A6’s 71 modulation sources can be used to trigger the envelope.</p> <p>The selected trigger source is activated when certain conditions exist. Specifically, when the selected trigger’s Input Level and Polarity characteristics (described below) are detected, the trigger is activated.</p> <p>Note that this is a <i>one shot</i> input: once the envelope starts its cycle, subsequent triggers are ignored until the envelope stops.</p> |
| | — | LEVEL | -100 ... +100 | <p>The A6 gets its signal to generate a trigger when the SOURCE reaches a certain LEVEL that you set (next) and when the source “moving” in a positive or negative direction, or both (next page under POLAR - polarity).</p> <p>This sets the level of the SOURCE (selected above) where triggering will take place.</p> <p>Note that if the POLAR setting (below) is set to one of the absolute (ABS) options, negative settings are treated as is they were positive.</p> |

| DISPLAY PAGE | PANEL LABEL | PARAMETER DISPLAY | OPTIONS or RANGE | DESCRIPTION |
|-------------------|-------------|-------------------|---|--|
| TRIG Continued | — | POLAR* | NEGATIVE BIPOLAR POSITIVE | The trigger will occur only when the source is “moving in a negative direction.” This means that a trigger is generated when the LEVEL setting is reached, but only if the source is decreasing in amplitude. The trigger occurs when the LEVEL is reached but the source can be either increasing or decreasing in amplitude. The trigger will occur only when the source is “moving in a positive direction.” This means that a trigger is generated when the LEVEL setting is reached, but only if the source is increasing in amplitude. |
| | | | ABS: Absolute – the following polarities treat positive and negative LEVEL settings as if they were all positive. | |
| | | | ABS NEGATIVE | <i>Absolute Negative:</i> a trigger is generated when the source is moving in a negative direction and reaches the absolute value of the LEVEL. |
| | | | ABS BIPOLAR | <i>Absolute Bi-Polar:</i> a trigger is generated when the source is moving in a either direction and reaches the absolute value of the LEVEL. |
| | | | ABS POSITIVE | <i>Absolute Positive:</i> a trigger is generated when the source is moving in a positive direction and reaches the absolute value of the LEVEL. |
| | — | MODE | NORM 1 NORM 2 FRERUN FR-SUS SUSREL MODTRG MOD-TG | Once the envelope is triggered or re-triggered, this parameter instructs the envelope how to execute its Attack, Decay, Sustain and Release stages. These seven modes are fairly elaborate, so an extended discussion with examples are presented starting on the next page. |
| | — | <PAGE> | TRIG RETRIG | Not only are envelopes triggered, they can also be configured to be re-triggered. Use soft knob 8 to toggle between the TRIG page and the RETRIG pages of parameters. |

* For an in-depth study of these polarities, see our discussion on **How Modulation Triggering Works** using an LFO source as the example. This topic starts on page 155.

An interesting attribute of the envelopes is that while they rely on a trigger source to start (an envelope is a trigger **destination**), they themselves can also be trigger **sources**. One of the more interesting properties of envelopes is the triggering capabilities of the envelopes’ parameters. As an example, an envelope can be configured so that a trigger is generated by an envelope when its attack stage reaches a certain level. This trigger can be used to start another envelope or an LFO as just a few possibilities.

Envelope Modes

The envelope `MODE` parameter on the `TRIG` page determines **how an envelope is triggered** (started) and **how it progresses through its stages** under various circumstances. There are seven envelope modes: Normal 1, Normal 2, Freerun, Freerun-Sustain, Sustain-Release 1, Mod-Trigger, Mod-Trig/Gate.

Here are some terms used in the following descriptions of the envelope modes. The descriptions get a little technical in breaking down the modes into their basic parts, but this will be valuable in understanding the intricate functions of the envelopes.

| | |
|-----------------------------|---|
| Note On | <p>A note is played from the A6's keyboard, Arpeggiator, or Sequencer, or a received MIDI Note. This term also includes the amount of time (the "duration") from the moment a note is played – a Note On event – until the key is let go – the Note Off event.</p> <p>The manual will sometimes refer to a Note On as a "key being played" or words to that effect. For simplicity, we'll use this phrase to mean any note played, whether it comes from the keyboard, the Sequencer or Arpeggiator, or a received MIDI Note.</p> |
| Note Off | <p>The corresponding Note Off event for a previous Note On. Like the Note On term, the manual will sometimes refer to a Note Off as a "key being let go" or words to that effect. We'll use this phrase to mean any note off message, whether it comes from the keyboard, the Sequencer or Arpeggiator, or a received MIDI Note.</p> |
| Sustain Pedal On | <p>the <code>SUSPDL</code> envelope parameter is <code>ON</code> (<code>DYN</code> parameter page) and the actual sustain pedal is depressed.</p> |
| Sustain Pedal Off | <p>the <code>SUSPDL</code> envelope parameter is <code>OFF</code> or the actual sustain pedal is not depressed or has been released.</p> |
| Modulation Source On | <p>when using the <code>MOD-TRIG</code> or <code>MOD-TRIG/GATE</code> modes, this phrase indicates any amount of time (duration) from the Key Note On event to the Key Note Off event .</p> |

The following pages detail the behavior of the six envelope modes. Keep in mind that during any stage of an envelope, the envelope may also be affected by any modulation, re-triggering, looping, etc.

NORM 1

A **NORM 1** envelope will proceed through its cycle to the Sustain stage as long as a key is being held down (Note On). The Release 1 stage starts when the key is let go (Note Off). But if the key is let go **before** the Sustain stage is reached, the envelope “jumps” to the Release 1 stage. Also, if the key is let go then immediately played again, the envelope will resume from its current level.

- Start:** The envelope is started by the beginning of a Note On event.
- Progress:** During the Note On, the envelope proceeds normally through Delay, Attack, Decay 1, and Decay 2 stages to the Sustain stage.
- Sustain:**
1. If the Note On is held until the Sustain stage is reached, the Note On or a Sustain Pedal On will hold the envelope at the Sustain level until a Key Off and a Sustain Pedal off occur. The envelope will then proceed to Release 1 and continue through to the end of the envelope. See **EXAMPLE 1**.
 2. If the Note Off occurs **before** the Sustain stage is reached, a Sustain Pedal On will “jump” and hold the envelope in the Sustain stage at the current level until a Sustain Pedal Off occurs. The envelope will then proceed to Release 1 and continue through to the end of the envelope. See **EXAMPLE 2b**.
- Key Release:**
1. If a Note Off event (assuming the Sustain Pedal is off) occurs **while** the envelope is in the Sustain stage, the envelope will proceed to Release 1 stage and progress normally through the envelope to the end. See **EXAMPLE 1** again.
 2. If a Note Off event (assuming Sustain Pedal is off) occurs **before** the envelope reaches the Sustain stage, the envelope will jump immediately to the Release 1 stage, at the current level, and proceed to the Release 2 level according to the time setting of the Release 1 stage. When the Release 2 stage is reached the envelope will proceed normally through to the end. See **EXAMPLE 2a**.

NORM 1, EXAMPLE 1

This is a **NORM 1** envelope with the Note Off occurring after the **SUSTAIN** stage was reached.

Note that a Sustain Pedal On will also hold the envelope at the **SUSTAIN** level.

When a Note Off or Sustain Pedal Off occurs, the envelope will proceed into the **RELEASE 1** stage.

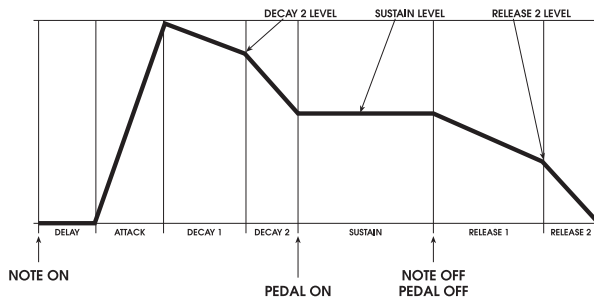

NORM 1, EXAMPLE 2

EXAMPLE 2a

This is a **NORM 1** envelope with the Note Off occurring during the **ATTACK** stage.

The envelope “jumps” to the **RELEASE 1** stage and proceeds into the **RELEASE 2** level.

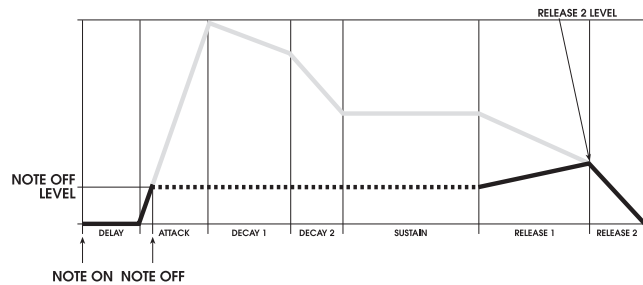

The gray lines in the illustration above indicate the envelope stages that are bypassed when a Note Off occurs before the **ATTACK** stage is complete. After removing the bypassed stages from the graph, the envelope shape looks more like the one here on the right.

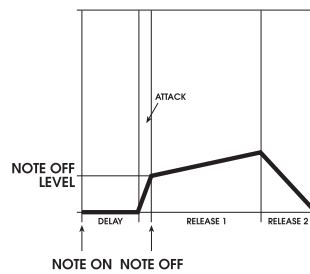

EXAMPLE 2b

When a sustain pedal is used, a Sustain Pedal On will “jump” to the **SUSTAIN** stage and hold at the Note Off level. When the Sustain Pedal is let go, the envelope will proceed into **RELEASE 1**.

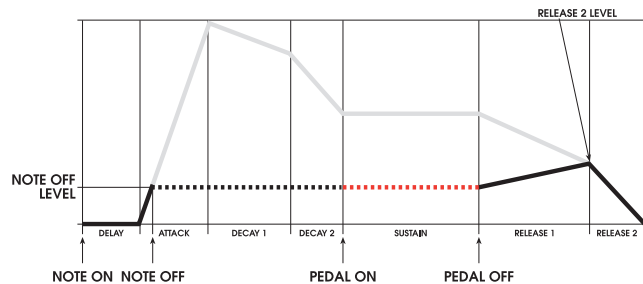

As with Example 2a, the gray lines in the illustration above indicate the envelope stages that are bypassed. After removing the bypassed stages from the graph, the envelope shape looks more like the one here on the right.

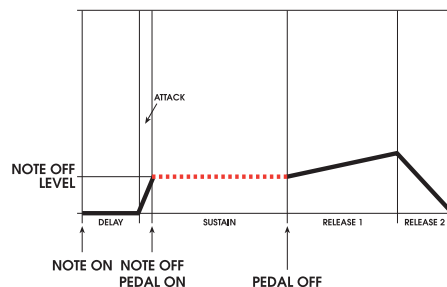

The duration of the **SUSTAIN** stage is as long as the sustain pedal is down.

NORM 2

A NORM 2 envelope is very similar to a NORM 1. The main difference is that a NORM 2 envelope jumps to the Release 2 stage (instead of the Release 1 stage in NORM 1) if the key is let go before the Sustain stage is reached.

- Start:** The envelope is started by the beginning of a Note On event.
- Progress:** During the Note On, the envelope proceeds normally through Delay, Attack, Decay 1, and Decay 2 stages to the Sustain stage.
- Sustain:**
1. If the Note On is held until the Sustain stage is reached, the Note On or a Sustain Pedal On will hold the envelope at the Sustain level until a Key Off and a Sustain Pedal off occur. The envelope will then proceed to Release 1 and continue through to the end of the envelope. (This is the same as NORM1 mode.) See **EXAMPLE 1**.
 2. If the Note Off occurs **before** the Sustain stage is reached, a Sustain Pedal On will “jump” and hold the envelope in the Sustain stage at the current level until a Sustain Pedal Off occurs. The envelope will then proceed to Release 2 and continue through to the end of the envelope. See **EXAMPLE 2b** (Note Off during **ATTACK**) and **3b** (Note Off during the **D1TIME**).
- Key Release:**
1. If a Note Off event (assuming the Sustain Pedal is off) occurs **while** the envelope is in the Sustain stage, the envelope will proceed to Release 1 stage and progress normally through the envelope to the end. See **EXAMPLE 1** again.
 2. If a Note Off event (assuming Sustain Pedal is off) occurs **before** the envelope reaches the Sustain stage, the envelope will jump immediately to the Release 2 stage, at the current level, and proceed to 0 according to the its time setting. See **EXAMPLE 2a** (Note Off during **ATTACK**) and **3a** (Note Off during **D1TIME**).

NORM 2, EXAMPLE 1

This is a NORM 2 envelope with the Note Off occurring after the **SUSTAIN** stage was reached.

Note that a Sustain Pedal On will also hold the envelope at the **SUSTAIN** level.

When a Note Off or Sustain Pedal Off occurs, the envelope will proceed into the **RELEASE 1** stage.

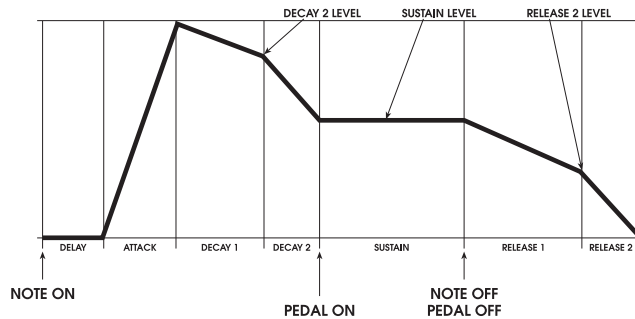

NORM 2, EXAMPLE 2

EXAMPLE 2a

This is a **NORM 2** envelope with the Note Off occurring during the **ATTACK** stage.

The envelope “jumps” directly to the **RELEASE 2** stage and proceeds to 0.

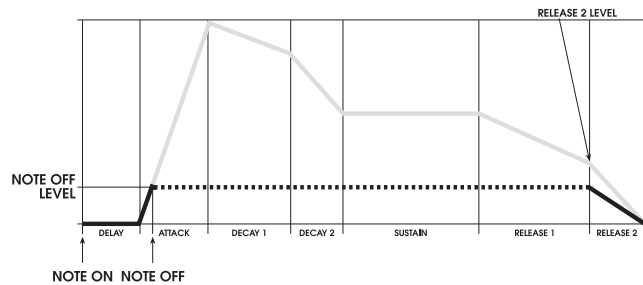

The gray lines in the illustration above indicate the envelope stages that are bypassed when a Note Off occurs before the **ATTACK** stage is complete. After removing the bypassed stages from the graph, the envelope shape looks more like the one here on the right.

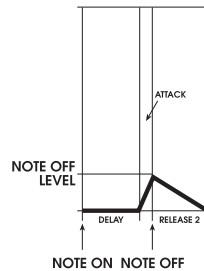

EXAMPLE 2b

When a sustain pedal is used, a Sustain Pedal On will “jump” to the **SUSTAIN** stage and hold at the Note Off level. When the Sustain Pedal is let go, the envelope will proceed into the **RELEASE 2** stage and proceed to 0.

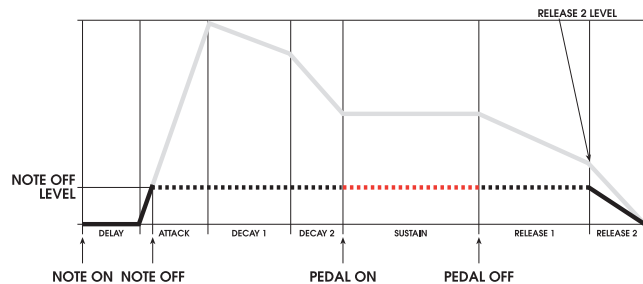

As with Example 2a, the gray lines in the illustration above indicate the envelope stages that are bypassed. After removing the bypassed stages from the graph, the envelope shape looks more like the one here on the left.

The duration of the Sustain stage is as long as the sustain pedal is down.

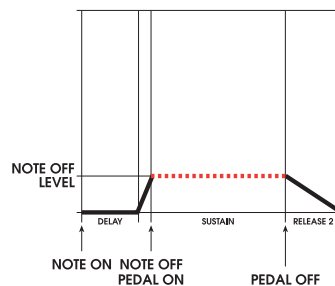

NORM 2, EXAMPLE 3

EXAMPLE 3a

This is a **NORM 2** envelope with the Note Off occurring during the **DECAY 1** stage.

The envelope “jumps” directly to the **RELEASE 2** stage and proceeds to 0.

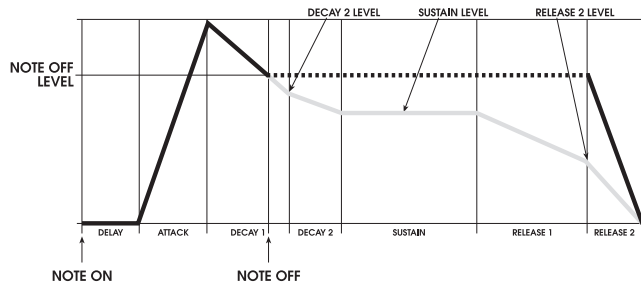

The gray lines in the illustration above indicate the envelope stages that are bypassed when a Note Off occurs before the **DECAY 1** stage is complete. After removing the bypassed stages from the graph, the envelope shape looks more like the one here on the right.

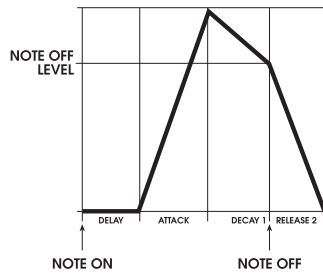

EXAMPLE 3b

When a sustain pedal is used, a Sustain Pedal On will “jump” to the **SUSTAIN** stage and hold at the Note Off level. When the Sustain Pedal is let go, the envelope will proceed into the **RELEASE 2** stage and proceed to 0.

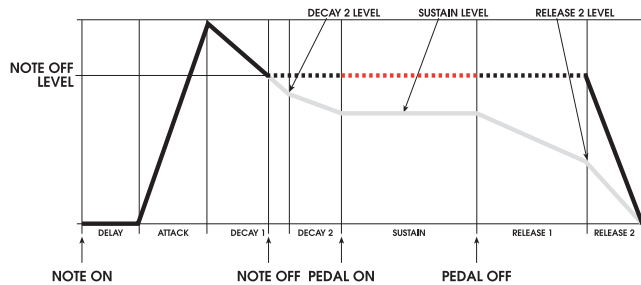

As with Example 3a, the gray lines in the illustration above indicate the envelope stages that are bypassed. After removing the bypassed stages from the graph, the envelope shape looks more like the one here on the left.

The duration of the Sustain stage is as long as the sustain pedal is down.

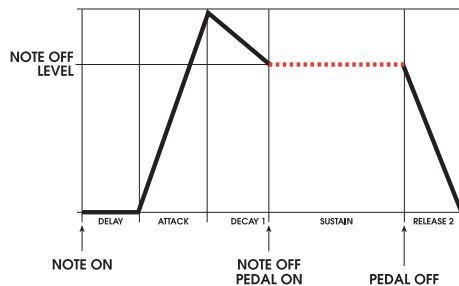

FRERUN

The FRERUN (“free-run”) envelope plays through its cycle even if the key or pedal is released before reaching the Sustain stage.

Start: The envelope is started by the beginning of a Note On event.

Progress: Once the envelope has started, regardless of Note On or Sustain status, the envelope proceeds normally through Delay, Attack, Decay 1, and Decay 2 stages to the Sustain stage.

Sustain: If a Note On **and/or** a Sustain Pedal On is held when the Sustain stage is reached, the Note On **and/or** the Sustain Pedal On will hold at the Sustain level until a Note Off and a Sustain Pedal Off occurs. The envelope will then proceed to Release 1 and continue through to the end of the envelope.

- Key Release:**
1. If a Note Off event (assuming the Sustain Pedal is Off) occurs **while** the envelope is in the Sustain stage, the envelope will proceed to Release 1 stage and progress normally through the envelope to the end.
 2. If a Note Off event occurs **before** the envelope reaches the Sustain stage (and the Sustain Pedal is off), the envelope will proceed through all remaining stages just as if the key was still being pressed. The only difference in this situation is that the envelope will pass through the Sustain stage without stopping.

FRERUN EXAMPLE

In a FRERUN envelope, the envelope will proceed through all stages no matter when the Note Off occurs.

A Sustain Pedal On will hold the envelope at the **SUSTAIN** level as long as the pedal is down.

When a Sustain Pedal Off occurs, the envelope will proceed into the **RELEASE 1** stage.

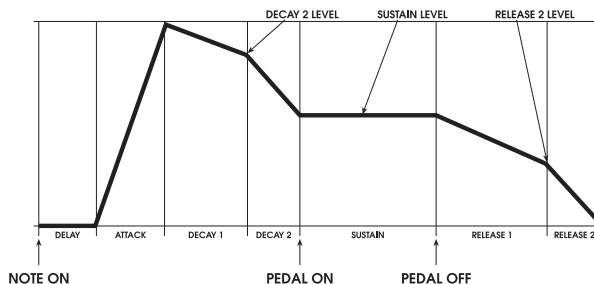

SUSREL

The SUSREL (Sustain-Release) envelope mode merges Sustain and Release 1 stages.

Start: The envelope is started by the beginning of a Note On event.

Progress: During the Note On, the envelope proceeds normally through Delay, Attack, Decay 1, and Decay 2 stages to the Sustain stage.

Sustain: While the envelope is “sustaining”, it will actually be **transitioning** from the Sustain level to the Release 2 level – the Sustain stage is effectively bypassed. When the Release 2 level is reached, the envelope will hold (“sustain”) at the Release 2 level if the Note On and/or Sustain Pedal are still On. When a Note Off or Sustain Pedal Off occur, the envelope will then proceed to the Release 2 stage through to the end of the envelope.

1. If the Note On is held until the Sustain level is reached, the Note On or Sustain Pedal On will allow the envelope to transition to the Release 2 level via the Sustain/Release 1 stage:

- a. if the Note On or Sustain Pedal On are held until the Release 2 Level is reached, the envelope will hold at that level until a Note Off and/or a Sustain Pedal Off occur. The envelope will then proceed to the Release 2 stage and continue through to the end. See **EXAMPLE 1**.
 - b. if the Note On and Sustain Pedal On are released before the Release 2 Level is reached, the envelope will jump to the Release 2 stage (at the current level) and proceed to 0 within the time of the Release 2 Stage. See **EXAMPLE 2**.
2. If a Note Off occurs before the Sustain stage is reached, a Sustain Pedal On will cause the envelope to jump to the Sustain/Release 1 Stage and begin the transition to the Release 2 level until a Sustain Pedal Off occurs. The envelope will then transition to (if not already at) the Release 2 stage time (at the current level) and proceed to 0 within the time of the Release 2 Stage. See **EXAMPLE 3b** (Note Off/Pedal On during D2TIME) and **EXAMPLE 4** (Note Off/Pedal On during D1TIME, Pedal Off during SUSREL).
- Key Release:**
1. If a Note Off event (assuming that Sustain Pedal is Off) occurs **while** the envelope is in the Sustain/Release 1 stage, the envelope will jump to the Release 2 stage and continue through to the end. See **EXAMPLE 2** again.
 2. If a Note Off event (assuming that Sustain Pedal is Off) occurs **before** the envelope reaches the Sustain/Release1 stage, the envelope will jump immediately to the Release 2 stage (at current level) and proceed to 0 according to the time setting of the Release 2 Stage. See **EXAMPLE 3a** (Note Off during D2TIME).

SUSREL, EXAMPLE 1

This is a SUSREL envelope with the Note Off occurring after the **RELEASE 2** stage was reached.

Note that a Sustain Pedal On will also maintain the transition through the SUSREL stage and remain at the **RELEASE 2** level until a Note Off or Pedal Off occurs.

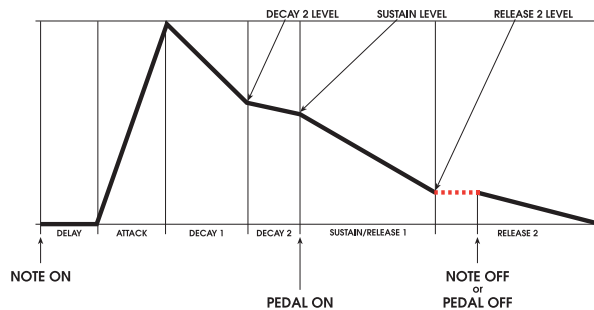

SUSREL, EXAMPLE 2

This is a **SUSREL** envelope with the Note Off occurring during the **SUSREL** stage, but before the **RELEASE 2** stage was reached.

The key concept to note here is that a Note Off or Pedal Off occurring during the **SUSREL** stage causes the envelope to jump directly to the **RELEASE 2** stage.

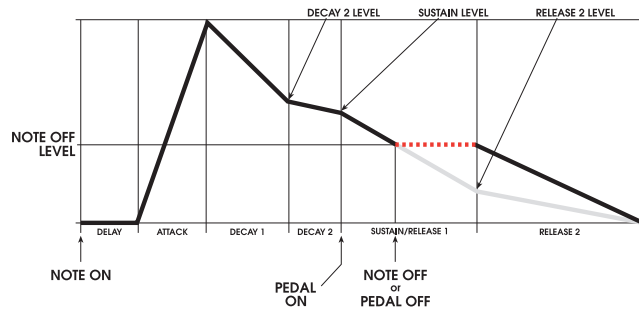

SUSREL, EXAMPLE 3

EXAMPLE 3a

This is a **SUSREL** envelope with the Note Off occurring during the **DECAY 2** stage. The envelope jumps directly to the **RELEASE 2** stage and proceeds to 0.

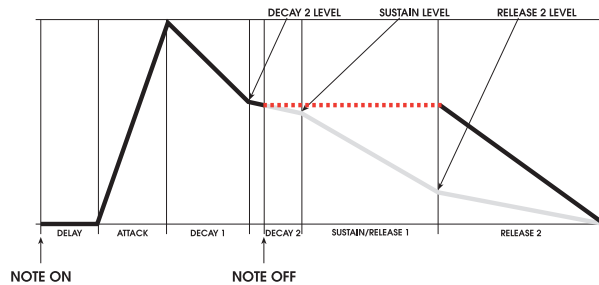

The gray lines in the illustration above indicate the envelope stages that are bypassed when a Note Off occurs before the **DECAY 2** stage is complete. After removing the bypassed stages from the graph, the envelope shape looks more like the one here on the right.

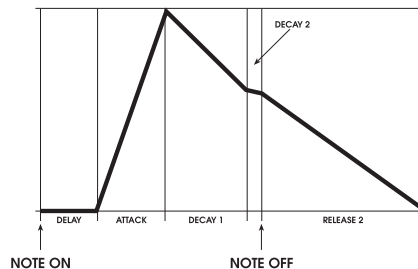

EXAMPLE 3b

If a Sustain Pedal On occurs during **DECAY 2**, the envelope will jump to the **SUSREL** stage and begin the transition into the **RELEASE 2** stage.

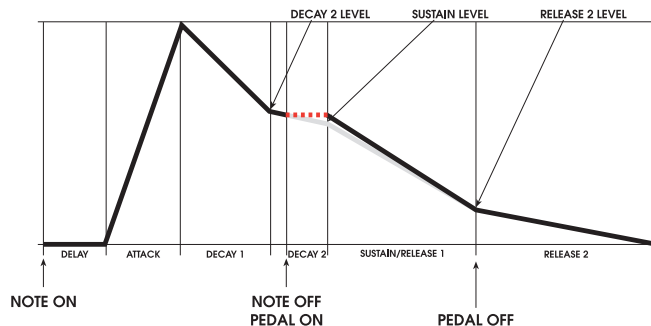

SUSREL, EXAMPLE 4

This is a SUSREL envelope with the Note Off occurring during the **DECAY 1** stage.

If a Sustain Pedal On occurs, the envelope “jumps” to the **SUSREL** stage and proceeds into **RELEASE 2**. If the Sustain Pedal Off occurs during the **SUSREL** stage, the envelope will jump to **RELEASE 2** for its final decay to 0.

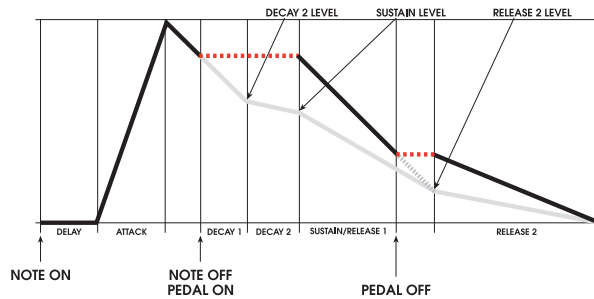

The gray lines in the illustration above indicate the envelope stages that are bypassed when a Note Off occurs before the **DECAY 1** stage is complete. After removing the bypassed stages from the graph, the envelope shape looks more like the one here on the right.

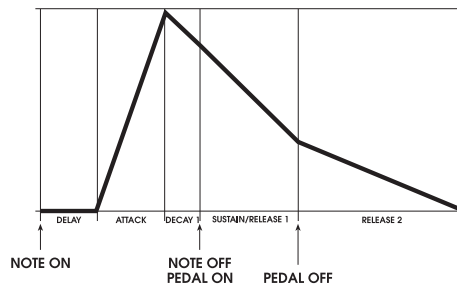

MODTRG

The MODTRG (“modulation trigger”) envelope mode is very similar in function to FRERUN, except that **the envelope is triggered by a user selectable modulation source** instead of the keyboard or other “note source” (the A6’s Sequencer, Arpeggiator, or a received MIDI Note).

- Start:** The envelope is started by an On level from the selected modulation source.
- Progress:** once the envelope is started, regardless of Modulation Input or Sustain status (key held down or the Sustain Pedal is down), the envelope will proceed normally through Delay, Attack, Decay 1, and Decay 2 stages (subject to modulation, Retriggering, Looping, etc...) to the **SUSTAIN** Stage.
- Sustain:** If the Sustain Pedal is down when the **SUSTAIN** Stage is reached, the pedal will hold at the **SUSTAIN** Level until the pedal is let go. Afterwards, the envelope will proceed to **RELEASE 1** and continue through to the end of the envelope.

MOD-TG

The MOD-TG (“modulation trigger-gate”) envelope mode is very similar in function to the NORM 1 mode, except that the envelope is triggered by a user selectable modulation input instead of the keyboard.

Start: The envelope is started by an On level from the selected modulation source.

Progress: During the Modulation Source On, the envelope proceeds normally through Delay, Attack, Decay1, and Decay2 stages to the Sustain stage.

Sustain:

1. If the Modulation Source On signal continues until the Sustain stage is reached, the Modulation Source On or SUSTAIN PEDAL ON will HOLD at the SUSTAIN Level until Modulation Input OFF and SUSTAIN PEDAL OFF, afterwards, the envelope will proceed to RELEASE1 and continue through to the end of the envelope.
2. If Modulation Input OFF occurs before the SUSTAIN Stage is reached, SUSTAIN PEDAL ON will "jump" and HOLD the envelope in the Sustain Stage at the Current Level until SUSTAIN PEDAL OFF, afterwards, the envelope will proceed to RELEASE1 and continue through to the end.

Gate (Release):

1. If a Modulation Input OFF (assuming Sustain Pedal is OFF) event occurs while the envelope is in the SUSTAIN stage, the envelope will proceed to RELEASE1 Stage and progress normally through the envelope to the end.
2. If a Modulation Input OFF (assuming Sustain Pedal is OFF) event occurs before the envelope reaches the SUSTAIN stage, the envelope will "**jump immediately to the RELEASE1 stage time**" (at current level) and proceed to the Release2 Level within the time of the Release1 Stage. When the RELEASE2 stage is reached the envelope will proceed normally through to the end.

Envelope Trigger Examples

When a MOD-TRIG or MOD-TRIG/GATE is selected in the MODE parameter, the three Trigger and four Re-Trigger parameters become available. These parameters are used to configure the triggering (and re-triggering) of the envelope.

In the following seven examples, we illustrate the interaction among the trigger SOURCE, LEVEL, and POLAR parameters. When using the Re-Trigger function, know that these parameters are identical to their Trigger counterparts. The Re-Trigger function contains a fourth parameter, STAGE (Re-Trigger Stage) which simply tells the envelope at what stage to start when re-triggered.

For simplicity, we'll use a TRIGGER/SOURCE of LFO1 for all seven examples. LFO1 will be producing a simple sine wave with a frequency of about 20Hz. We'll also use a LEVEL value of +75 for the examples, with the exception of **EXAMPLE 4** that assigns a LEVEL value of -45, just so you can see how a negative Level value affects the point at which a trigger is generated.

The main differences among the examples exist in the TRIGGER/POLAR setting so that you can see the effect of the six Polarity types. Each of the examples has a different Polarity selected, with the exception of **EXAMPLE 4** that has a positive polarity like **EXAMPLE 1** but has a negative Level setting.

How Modulation Triggering Works

When a modulation source is selected to trigger an envelope, the envelope ignores Note On messages (the keyboard, MIDI Notes, and so forth) and instead looks at the selected mod source for its trigger signal. In the examples below, we chose LFO 1 but the trig source can be another envelope, the Pitch Wheel, a foot switch and so on.

Before triggering takes place, the envelope “looks” at the mod source – in this case LFO 1 – for certain conditions that generate the trigger. When these conditions have been met, the trigger occurs and the envelope plays.

In **EXAMPLE 1**, the “conditions to be met” are: 1. the LFO must reach a level on its cycle of 75 (LEVEL value of 75) and 2. when this level of 75 is reached, the LFO must be “moving in a positive direction” or **rising** in level (POLAR setting of POSITIVE). Notice that the trigger is generated on the LFO’s “up slope” when it reaches a level of 75.

In **EXAMPLE 2**, the same LFO and level setting of 75 are used but this time the envelope will look for the LFO to be “moving in a negative direction” or **falling** in level (POLAR setting of NEGATIVE). The trigger is generated on the LFO’s “down slope” when it reaches a level of 75.

In **EXAMPLE 3**, polarity is set to BIPOLAR or bi-directional. This means that triggers are generated whenever the LFO’s level = 75 no matter what direction the slope is going.

In the examples, take particular note of the shaded areas of the graphs. The light areas indicate that the trigger is on and the dark areas indicate that the trigger is off.

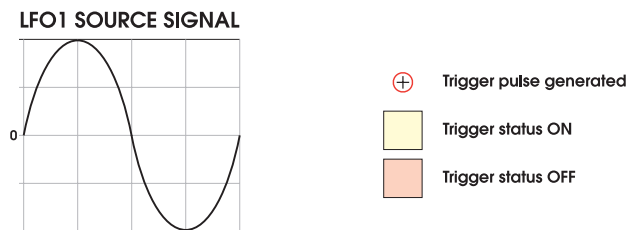

EXAMPLE 1

User Parameters:

Trigger In Level = 75

Trigger Polarity = POSITIVE

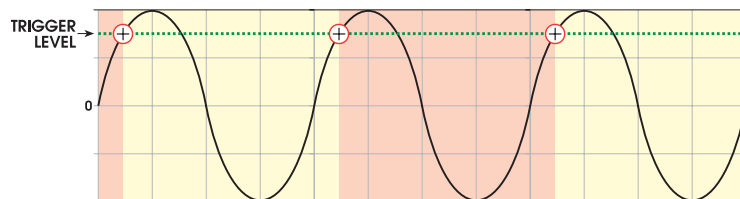

EXAMPLE 2

User Parameters:
Trigger In Level = 75
Trigger Polarity = NEGATIVE

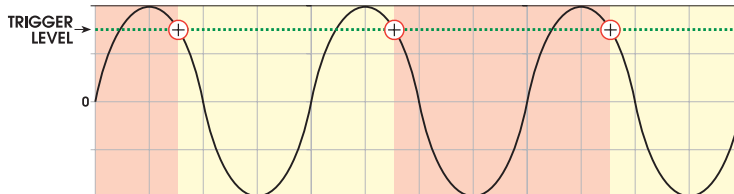

EXAMPLE 3

User Parameters:
Trigger In Level = 75
Trigger Polarity = BIPOLAR

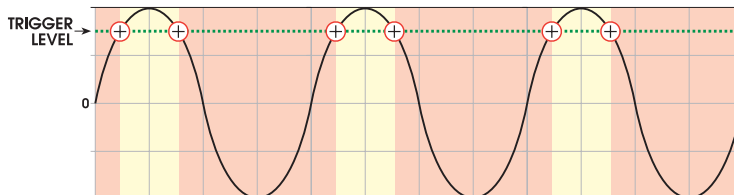

EXAMPLE 4

User Parameters:
Trigger In Level = -45
Trigger Polarity = POSITIVE

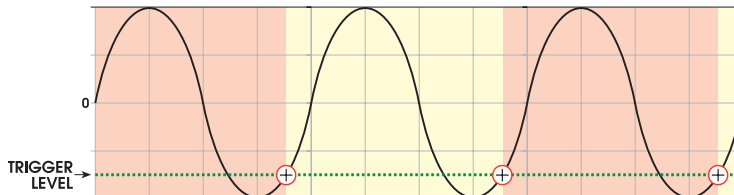

In **EXAMPLES 5, 6 and 7**, the envelope looks at the LFO for *absolute values*: positive or negative attributes are ignored – just the level of 75 is used.

EXAMPLE 5

User Parameters:

Trigger In Level = 75

Trigger Polarity = ABS
BIPOLAR

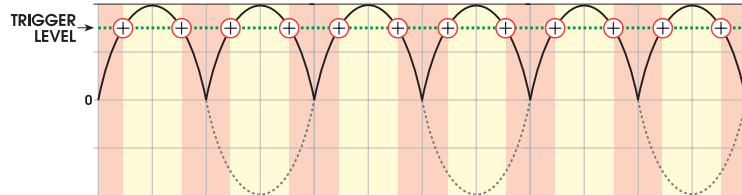

EXAMPLE 6

User Parameters:

Trigger In Level = 75

Trigger Polarity = ABS
POSITIVE

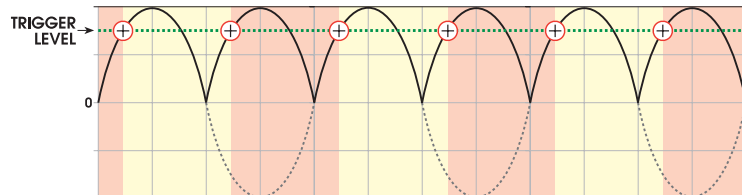

EXAMPLE 7

User Parameters:

Trigger In Level = 75

Trigger Polarity = ABS
NEGATIVE

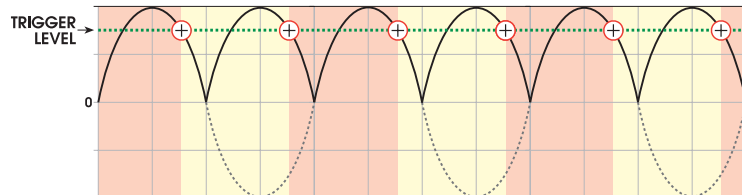

RETRIG Page

The parameters of the RETRIG page are identical to those of the TRIG page. RETRIG, however, adds an additional parameter called **STAGE**.

When re-triggering an envelope, you have the added ability to determine at what stage in the envelope's cycle where re-triggering takes place. By contrast, the first trigger that an envelope receives (TRIG parameters) **always** starts at the DELAY stage. You use soft knob 5 to select the desired stage. When re-triggered, the envelope will start at the beginning of the selected stage:

- DEL DELAY stage
- ATK ATTACK stage
- D1 D1TIME (**DECAY 1**) stage
- D2 D2TIME (**DECAY 2**) stage
- SUS SUSTAIN level; note that sustain will be by-passed if the key or sustain pedal is not down.
- R1 R1TIME (**RELEASE 1**) stage

DYN Page Parameters

The **DYN** or Dynamics functions permit you to modulate certain parameters of an envelope “live” or as you are playing the A6. To use a current computer phrase, we could say that dynamics are performance parameters that happen “in real time.”

Parameters in this page deal with how the envelope is affected by the way notes are played or if a sustain pedal is used. When a parameter is modulated *dynamically*, we mean that the modulations occur **as you are playing** and depend, to a large degree, on **how** you are playing. For example, if the **RESET** parameter is set to **LEGATO**, legato playing will affect the envelope behavior differently than staccato playing. Employing the **VELMOD** parameter allows you to control the output level of the envelope by velocity – how hard or soft you’re playing.

| DISPLAY PAGE | PANEL LABEL | PARAMETER DISPLAY | OPTIONS or RANGE | DESCRIPTION |
|--------------|--------------------|---------------------------------|------------------|--|
| DYN | DYNAMICS Button | RESET | | Each envelope is assigned to a particular voice. Once an envelope begins its cycle, this parameter determines what the envelope should do if its voice plays a new note before the cycle is completed. |
| | | | | If the voice plays a new note while the envelope is in progress... |
| | | | NORMAL | ... the envelope will always restart its cycle from the beginning. In other words, the envelope is “reset”. |
| | | | LEGATO | ... the envelope will continue from its present stage and level with the new note. Legato playing is the most common way for this to occur. If, however, you begin playing staccato, the envelope will reset as in NORMAL mode. |
| | | | RE-ASSIGN | ...the envelope will behave as in Legato mode, with the exception that if the voice is being reassigned from a different Program in a Mix, it will continue on from the present stage according to the new Program’s envelope. |
| | | | ANALOG | ...the envelope will start its attack stage from the present level, not necessarily zero. |
| | | SUSPDL Sustain Pedal Control | OFF, ON | Turns Sustain Pedal control on and off for the envelope. If the envelope reaches the SUSTAIN stage and this parameter is ON , holding the sustain pedal down will hold the envelope in its Sustain stage. When the pedal is let go, the envelope proceeds to the Release stages. |

| DISPLAY PAGE | PANEL LABEL | PARAMETER DISPLAY | OPTIONS or RANGE | DESCRIPTION |
|------------------|-------------|-------------------------------------|------------------|---|
| DYN Continued | | KEYTRK Key Tracking | -100 ... +100 | Key Tracking allows you to dynamically alter the time settings of the selected envelope's stages (except Delay and Attack) by the Note Number that triggered this envelope. When positive settings are used, the high notes add time to D1, D2, R1 and R2 time settings, making the envelope take longer to complete. Low notes subtract from these time settings. The note that determines the mid-point is the KTBASE parameter, next. |
| | — | KTBASE Key Tracking Base Note | C0 ... G10 | This parameter sets the midpoint between the range of notes where adding time to the envelope and subtracting time occurs. This parameter spans the entire range of MIDI notes from C0 to G10. |
| | — | LVLTRK Level Tracking | -100 ... +100 | This parameter allows you to dynamically alter the LEVEL setting – the overall output level – of the selected envelope by the Note Number that triggered this envelope. A setting of 0% means no modulation. |
| | — | VELMOD Level Velocity Modulation | -100 ... +100 | This parameter allows you to dynamically alter the LEVEL setting – the overall output level – of the selected envelope by the Velocity of the key that triggered this envelope. A setting of 0% means no modulation. |
| | — | RELMOD Release 2 Modulation | -100 ... +100 | This parameter allows you to dynamically alter the Release2 TIME setting of the selected envelope by the Note Number that triggered this envelope. See examples below. |

Key Tracking and RELMOD Release 2 Modulation

The TIME and RELMOD parameters modulate the stage time settings (as set in the TIME page) by the Note Number that triggered the envelope. If you refer back to page 54 when we covered Keyboard Properties, each key of the A6's keyboard as well as any received MIDI Note is assigned a number. This number is used by the A6 to determine what musical note or notes to play.

The KEYTRK Key Tracking setting affects Decay 1, Decay 2, Release 1 and Release 2 stage times. The RELMOD Release 2 Mod setting affects Release 2 only. For our discussion, let's use Middle C (C5) as the KTBASE note.

At Middle C, the selected envelope's stages are not affected and will proceed according to the times as set in the TIME page. Consider Middle C (or any other note selected as the KTBASE) as the "neutral note".

Positive Values: If `KEYTRK` and `RELMOD` are set to 100, the envelope stage times will double in speed with each octave above Middle C, and halve in speed with each octave below Middle C.

Negative Values: If `KEYTRK` and `RELMOD` are set to -100, the envelope will double in speed with each octave **below** Middle C, and halve in speed with each octave **above** Middle C. Negative values have reverse effect of positive settings.

LOOP Page Parameters

Each of the three envelopes has the ability to *loop* – repeat selected stages over and over. The parameters in the Loop page allow you specify how the loop behaves:

- **When** it starts: as the envelope proceeds through its stages – according to the settings in the `TIME`, `LEVEL`, `TRIG` and `DYN` pages – you select the stage of the envelope when looping starts. As an example, you can set the envelope to start looping when the **DECAY 2** stage is complete, as shown in the illustration below.
- **Where** it starts looping: once the loop is instructed to start, you specify the stage of the envelope where the loop begins. As an example, you can set the loop's start point to be the **ATTACK** stage, as shown in the illustration below.
- **How** the looping continues: you can instruct the loop to repeat a specific number of times (from 1 to 240), repeat until you release the key (or a MIDI Note Off is received), repeat as long as the Sustain Pedal is down, or cycle infinitely.

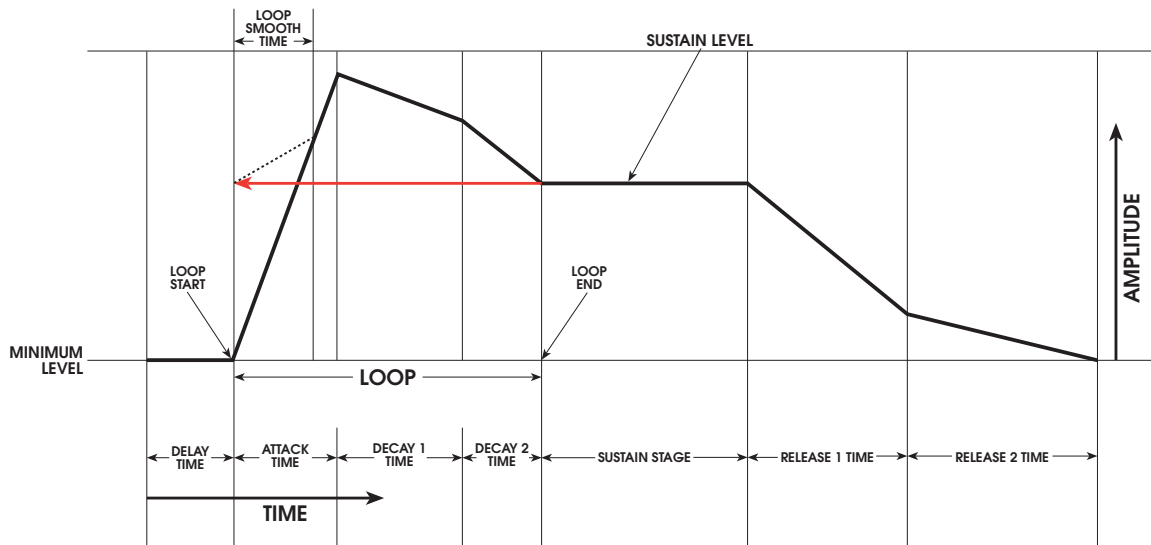

This example shows the loop path for the following parameters:

```

Loop END      = DECAY 2
Loop START   = ATTACK
SMOOTH Time  = user selectable, shown above as about 2/3 of the Attack time.
SSHAPE      = LINEAR
    
```

Envelope looping simply instructs an envelope to repeat a certain stage or stages. You can set up a loop to repeat only one stage – for example **DECAY 1** – or up to all available stages – **DELAY** through **RELEASE 1**. The keywords here are **available** stages: **RELEASE 2** cannot be selected as a loop end stage.

In the following table of loop parameter descriptions, it's important to understand

how we use the the term *stage*. It refers to the same envelope parameters as before, but when describing the loop start function, the loop starts at the **beginning** of the selected stage only. For example, you cannot start a loop during the Attack stage's rise time, only at the point where the Attack stage starts.

By the same token, for a loop's end functions, the loop finishes at the **completion** of the last stage before the loop end stage. For example, you cannot end a loop at some point during the Decay 2 stage's fall time, only at the point where the Decay 2 stage is completed.

| DISPLAY PAGE | PANEL LABEL | PARAMETER DISPLAY | OPTIONS or RANGE | DESCRIPTION |
|--------------|-------------|---|------------------|--|
| LOOP | LOOP button | As you select and adjust the Loop parameters below, note how the display changes to reflect your settings. The box will change size and position with new START and END points and will display a representation of the selected curve. | | |
| — | START | DEL Delay ATK Attack D1 Decay 1 D2 Decay 2 SUS Sustain | | <p>This parameter is used to select the stage in the envelope where the loop begins.</p> <p>The loop will cycle through the envelope's stages that are between what you select as the START and END stages. For example, if you set the START stage to be ATK and the END stage to be D2, the envelope will repeat</p> <p style="text-align: center;">ATK → D1 → D2</p> <p>The number times the loop cycles or repeats is selected by the COUNT parameter, described on the next page.</p> |
| — | END | ATK Attack D1 Decay 1 D2 Decay 2 SUS Sustain R1 Release 1 | | <p>This parameter actually performs two functions:</p> <ol style="list-style-type: none"> 1. As its name implies, this is the stage in the envelope where the loop ends. If the loop repeats, this is also the stage where the loop returns to the loop's START stage. 2. This is also the stage in the envelope where the loop gets its initial instruction to start looping and begins a smoothed transition to the Loop Start stage. The transition is an amount of time that is set by the SMOOTH and SSHAPE parameters. <p>So when setting this parameter, keep in mind that this is the stage in the envelope where the loop receives both its command to start and its command to return to the first stage in the loop after each loop cycle.</p> |
| — | COUNT | | 1 ... 240 | <p>This parameter determines how many times the selected envelope will loop.</p> <p>This selects a specific number of loop cycles up to 240. After the last cycle is completed, the envelope is released.</p> |

| DISPLAY PAGE | PANEL LABEL | PARAMETER DISPLAY | OPTIONS or RANGE | DESCRIPTION |
|-------------------|-------------|------------------------|--|--|
| LOOP Continued | — | COUNT Continued | SUSTAIN INFINITE | <p>The loop will continue to cycle until the key is let go (or the A6 receives a MIDI Note Off). If you're using a sustain pedal, the loop will cycle as long as the pedal is down.</p> <p>The loop will cycle infinitely. There are, however, differences between infinite looping of ENV 3 and ENVs 1 and 2. ENV 3, which is dedicated to the amplitude of the voice, will literally loop forever or until you change to another Program or power the A6 off.</p> <p>If ENV 1 and ENV 2 are set to an infinite loop, they will loop until the Release 2 time of ENV 3 reaches its 0 level.</p> |
| | — | TYPE | FORWARD REVERSE ROKROL | <p>This parameter determines how the loop cycles.</p> <p>FORWARD The loop cycles normally in a forward direction. Smoothing and Count settings will be in effect.</p> <p>REVERSE The loop cycles backward through the stages. Smoothing and Count settings will be in effect.</p> <p>ROKROL "Rock-n-Roll": The loop cycles backward and forward through the stages. Count settings will be in effect but Smoothing is ignored as it is not needed.</p> |
| | — | SMOOTH Smooth Time | 2M ... 131.055 | <p>When a loop repeats, it is quite possible that the level of the start stage will be different than the level of end stage. This may cause the envelope to sound uneven or choppy each time the loop cycle starts over.</p> <p>While this may be desirable in some cases (just set SMOOTH to 0), you can adjust the transition into the level of the start stage to be gradual, accomplished by a function called <i>smoothing</i>.</p> <p>This parameter sets the amount of time smoothing will take where 0 is instantly and 65535 is maximum, approximately 32 seconds.</p> |
| | | SSHAPE Smooth Shape | LINEAR EXP 1, 2 & 3 LOG 1, 2 & 3 SCURV1 & 2 | <p>Selects the slope that the Smooth Time will follow during the smoothing transition.</p> <p>These curves are the same as the envelopes' Stage Slopes – see page 139.</p> |

Some Important Notes About Envelope Looping

- You can think of the Smooth parameter as another envelope “stage”. It has Time (the SMOOTH parameter) and Slope (the SSHAPE parameter) properties just like the other stages. Just keep in mind that smoothing is used strictly for the purpose of linking two of the standard stages in order to form a loop. If SMOOTH is set to 2M, the Smoothing “stage” executes so quickly, it has the effect of linking the selected START and END stages to each other directly.

But you should keep in mind that if the levels of the START and END stages are different – as they are likely to be – you may hear a jump in levels every time the loop cycles back to the START stage.

- When adjusting loop points, if a loop END value is selected that would be **equal to or before** the loop START, the loop START will continue to step back to accommodate the new loop end. The same would be true of adjusting the loop START to be equal or greater than the END point.
- An envelope will start looping at the **beginning** of the stage you select for the END parameter. As an example, if D2 is selected in the END parameter, the envelope starts looping the moment D2 starts. Another way of looking at this is that the envelope starts looping the moment D1 **ends**. Either way, once the envelope starts looping, the remaining stages will not be available until looping is completed as set by the COUNT parameter.

So when selecting START and END stages, the setting of the envelope’s MODE on the TRIG page (see the description on page 144) must be taken into consideration.

Using the example above, if NORM 1 is the mode, the envelope will transition to RELEASE 1 when the loop ends, bypassing the D2 and SUSTAIN. This is identical to the response of NORM 1 mode when playing the keyboard: if a key is released prior to the SUSTAIN stage, the envelope transitions immediately to R1.

If the mode is set to FRERUN, the envelope proceeds through the remaining stages when looping ends. This is identical to the response of FRERUN mode when playing the keyboard: if a key is released prior to the SUSTAIN stage, the envelope proceeds through the remaining stages.

- If you select R1 to be the Loop END stage, **the envelope will not begin looping until the Sustain portion of the envelope is complete**. Since an envelope’s Sustain stage ends when a Note Off occurs, the envelope will not start looping until it gets a Note Off.

MOD Pages

In addition to the modifications offered by the TRIG and DYN pages, each envelope can be modulated by any of the A6's 71 mod sources. In fact, three separate mod paths can be created per envelope from the three MOD 1, MOD 2 and MOD 3 pages. This provides outstanding versatility in customizing the envelopes to a particular need.

MOD 1, MOD 2 and MOD 3 are identical, so the following table applies to all three:

| PAGE | PARAMETER | OPTIONS or RANGE | DESCRIPTION |
|-------------------------|---------------------|---|--|
| MOD 1 MOD 2 MOD 3 | SOURCE | Any of the A6's 71 modulation sources. See Appendix B. | Use soft knob 1 to scroll through the list of possible modulation sources. |
| | LEVEL | -100 ... +100 | This parameter sets the amount of modulation that will affect the selected destination. Keep in mind that negative values invert the action of the selected source. For example, if Velocity is the source and a negative value for LEVEL is used, playing harder will reduce the level of the destination. |
| | OFFSET | -100 ... +100 | This parameter sets the <i>offset</i> or fine adjustment for the selected modulation level. |
| | ENABLE | OFF, ON | This parameter is used to turn the selected modulation on or off. Use soft knob 5 or the panel buttons along the upper edge of the ENV 1 , ENV 2 and ENV 3 sections. |
| | DEST Destination | DELAY TIME ATTACK TIME DECAY 1 TIME DECAY 2 TIME REL 1 TIME REL 2 TIME ENV LEVEL SUS LEVEL | Use soft knob 2 to scroll through the list of possible modulation destinations. These destinations are eight envelope parameters described earlier in this Chapter. |

ENVELOPE EXAMPLES

Now that we've covered envelope functions in detail, let's take a look at a few envelopes that can be created in the A6. The envelope depicted on page 135 represents the most basic envelope contour: all stages are used, they're all linear and all levels have positive values.

The following five examples are just a few of the endless variations that can be accomplished on the A6, but illustrate the flexibility of these powerful modulations.

EXAMPLE 1: BI-POLAR

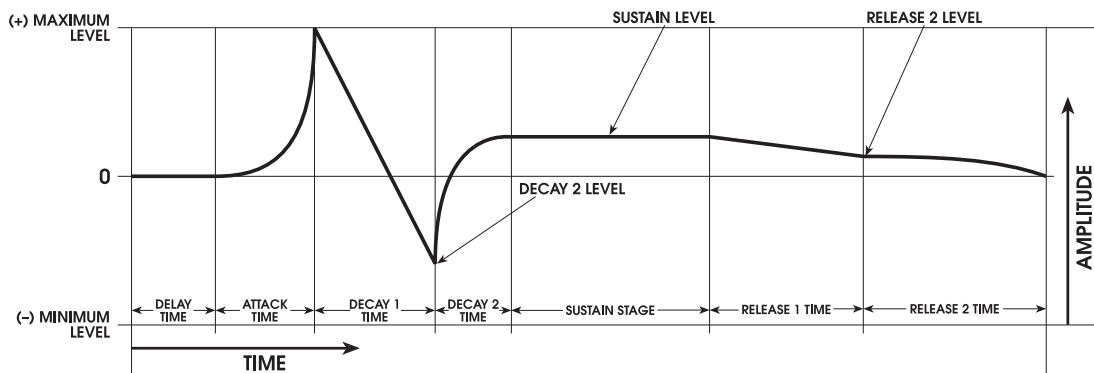

```

DELAY Time      5.99 S
ATTACK Time    16.50 S
Attack SHAPE   EXP 1
D1TIME        15.90 S
Decay1 SHAPE   LINEAR
D2LEVEL       -45
D2TIME        7.95 S
Decay2 SHAPE   LOG 2
SUSTAIN Level  25
R1TIME        12.50 S
Release1 SHAPE LINEAR
R2LEVEL        9
R2TIME        16.06 S
Release2 SHAPE EXP 1

Envelope OFFSET 0
Envelope LEVEL  100
Envelope POLAR  POSWAV

```

Bi-Polar envelopes like this one are only available for **ENV1** and **ENV2**. Also, this envelope can be inverted by switching **POLAR** from **POSWAV** to **NEGWAV**.

EXAMPLE 2: BI-POLAR with OFFSET plus LEVEL Changes

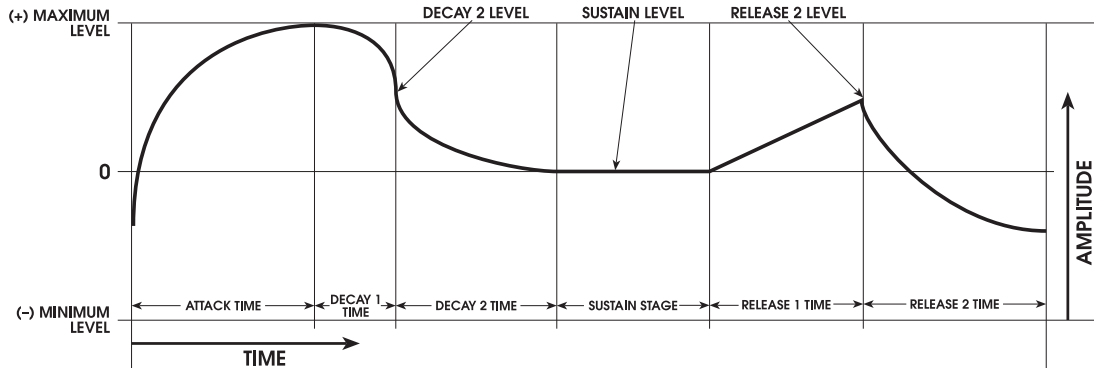

```

DELAY Time           OFF (no Delay stage)
ATTACK Time          4.82 S
Attack SHAPE         LOG 1
D1TIME               2.34 S
Decay1 SHAPE         EXP 2
D2LEVEL              Set to 79 but is effectively 60 after adjusting for Offset
D2TIME               4.50 S
Decay2 SHAPE         EXP 1
SUSTAIN Level        23
R1TIME               2.92 S
Release1 SHAPE       LINEAR
R2LEVEL              Set to 72 but is effectively 50 after adjusting for Offset
R2TIME               3.92 S
Release2 SHAPE       LOG 1

Envelope OFFSET      -35
Envelope LEVEL        100
Envelope POLAR        POSWAV
    
```

This example shows the relationship between the Offset and the envelope's Attack and Release2 stages. Notice that the envelope **will always begin** from the "0-plus-Offset" level. Likewise, Release 2 **will always end at the same level where the envelope started**. In this example, Offset is -35, shifting the envelope downward. Thus the envelope starts below 0 and rises from there during Attack.

This example also shows how the envelope's Level is used to increase the amplitude of the envelope when Offset is used. Since the Offset is set to -35 and the envelope Level is set to 100, the Attack Stage actually reaches its maximum point at +65, and no stages above the 0 line can exceed that value.

The stage Levels do not behave **exactly** as they appear in the illustration. This is because the envelope Level is set to 100 and the Offset to -35. For example, Decay 2 Level is set to 79 (more than 3/4 between 0 and the maximum). But because it is Offset by -35 and amplified by 100 the the resulting level (internally calculated) is about 60 where it appears in the illustration.

EXAMPLE 3: BI-POLAR with Output LEVEL Clipping and RELEASE HOLD

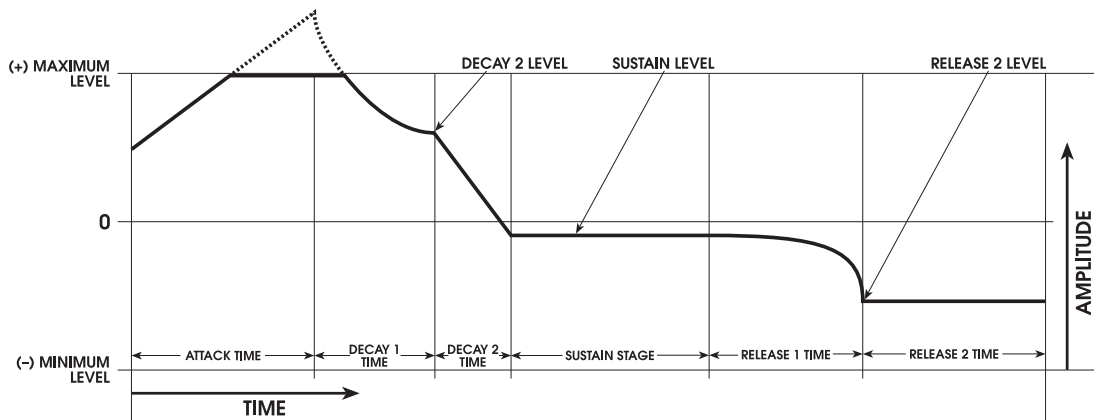

| | |
|-----------------|---|
| DELAY Time | OFF (no Delay stage) |
| ATTACK Time | 8.67 S |
| Attack SHAPE | LINEAR |
| D1TIME | 7.58 S |
| Decay1 SHAPE | LOG 1 |
| D2LEVEL | Set to 0 but is effectively 60 after adjusting for Offset |
| D2TIME | 3.70 S |
| Decay2 SHAPE | LINEAR |
| SUSTAIN Level | Set to -59 but is effectively -9 after adjusting for Offset |
| R1TIME | 2.92 S |
| Release1 SHAPE | EXPO 2 |
| R2LEVEL | Set to -100 but is effectively -50 after adjusting for Offset |
| R2TIME | 131.07 S (Maximum, causing the HOLD LED to light.) |
| Release2 SHAPE | Can be set to anything but is ignored |
| Envelope OFFSET | +50 |
| Envelope LEVEL | 100 |
| Envelope POLAR | POSWAV |

This example shows another relationship between the Offset and the envelope Level. Since the envelope Level is set to 100, the level from the start of the envelope to the maximum Output Level is 100. After the Offset is adjusted to +50, this pushes the top half of the Attack segment beyond the maximum Output Level. The envelope levels are **calculated** beyond the maximum, but are **clipped** at the maximum.

The HOLD function for the Release stage is also shown here. When the R2TIME is set to its maximum value, it is set to HOLD mode. In this mode, when the envelope reaches the Release2 Level, it holds at that Level infinitely until the Voice is released.

EXAMPLE 4: Classic “ADSR” – Positive Amplitude Envelope with Bypassed Stages

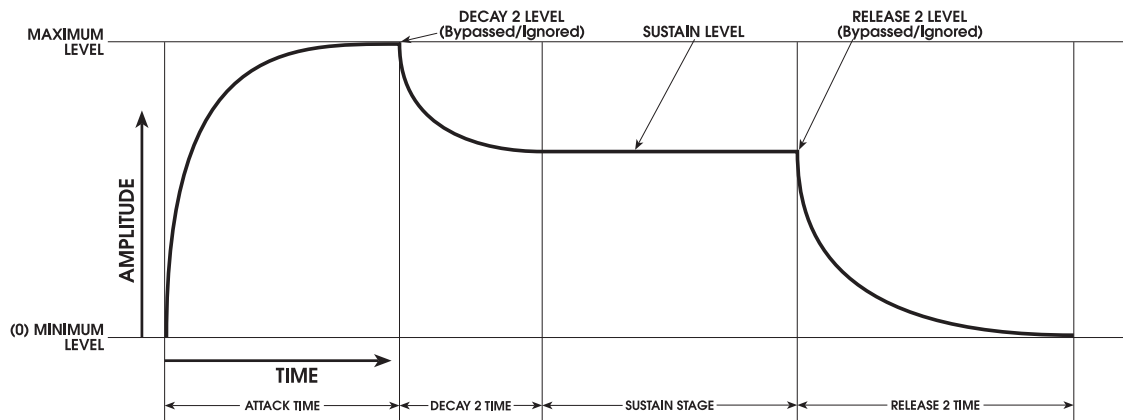

| | |
|-----------------|---|
| DELAY Time | OFF (no Delay stage) |
| ATTACK Time | 2.60 S |
| Attack SHAPE | LOG 3 |
| D1TIME | Set to 0 which bypasses this stage |
| Decay1 SHAPE | Bypassed: can be set to anything but is ignored |
| D2LEVEL | Bypassed: can be set to anything but is ignored |
| D2TIME | 1.46 S |
| Decay2 SHAPE | LOG 1 |
| SUSTAIN Level | Set to 75 but is effectively -9 after scaling |
| R1TIME | Set to 0 which bypasses this stage |
| Release1 SHAPE | Bypassed: can be set to anything but is ignored |
| R2LEVEL | Bypassed: can be set to anything but is ignored |
| R2TIME | 3.29 S |
| Release2 SHAPE | LOG 2 |
| Envelope OFFSET | 0 |
| Envelope LEVEL | 100 |
| Envelope POLAR | POSMAV |

This example illustrates bypassing stages to create new envelope functionality. Notice that Decay2 Level and Release2 Level are ignored. This is because Attack always rises to the maximum Output Level – set by the LEVEL parameter in the LEVEL page – at which time the envelope decays (via Decay2 Time) to the next stage level Sustain.

EXAMPLE 5: A(S)R – Positive Amplitude Envelope with Additional Bypassed Stages

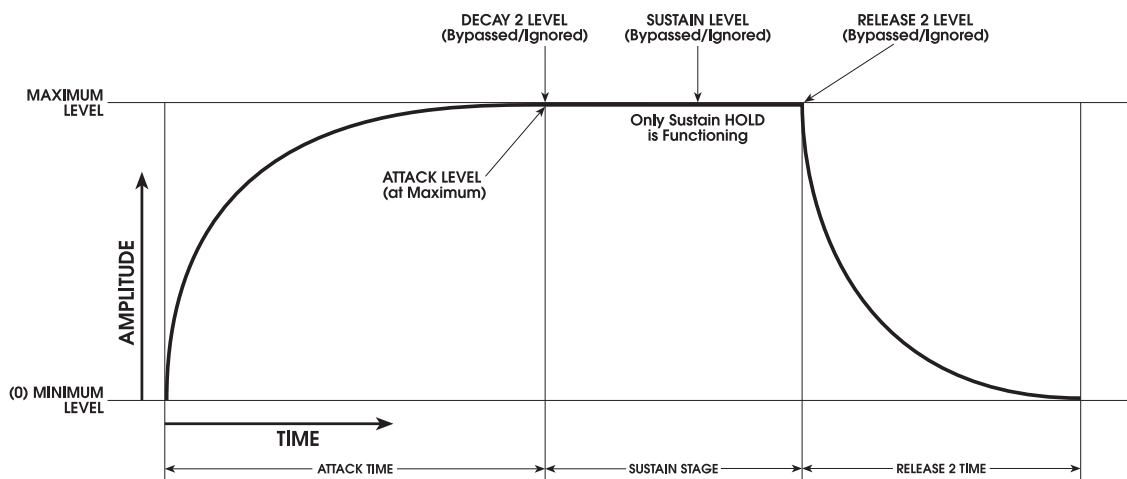

```

DELAY Time          OFF (no Delay stage)
ATTACK Time         3.20 S
Attack SHAPE        LOG 3
D1TIME              Set to 0 which bypasses this stage
Decay1 SHAPE        Bypassed: can be set to anything but is ignored
D2LEVEL             Bypassed: can be set to anything but is ignored
D2TIME              Set to 0 which bypasses this stage
Decay2 SHAPE        Bypassed: can be set to anything but is ignored
SUSTAIN Level       Bypassed: superceded by the ATTACK stage
R1TIME              Set to 0 which bypasses this stage
Release1 SHAPE      Bypassed: can be set to anything but is ignored
R2LEVEL             Bypassed: can be set to anything but is ignored
R2TIME              2.50 S
Release2 SHAPE      LOG 2

Envelope OFFSET     0
Envelope LEVEL      100
Envelope POLAR      POSWAV
    
```

This example shows the functionality of an A(S)R envelope. As always, the Attack stage rises to maximum, and proceeds to the next available Decay stage. In this case, since D1TIME and D2TIME are set to 0, the “next available Decay stage” does not exist, and the envelope proceeds to the Sustain stage.

As the Sustain stage is encountered, maximum level is held if a key is being held down or a sustain pedal is depressed. When the key or pedal is let go, the envelope proceeds from its current level (maximum, in this case) to Release2. Because Release2 is our exit stage and always decays to zero (plus Offset, if any), this functions exactly as an A(S)R envelope.

With this same method, a simple Attack/HOLD envelope could be created by setting the Release2 Time to HOLD (maximum).

CHAPTER 7

PROGRAM FUNCTIONS PART 3: LFOs, SAMPLE & HOLD AND PROCESS

LOW FREQUENCY OSCILLATORS

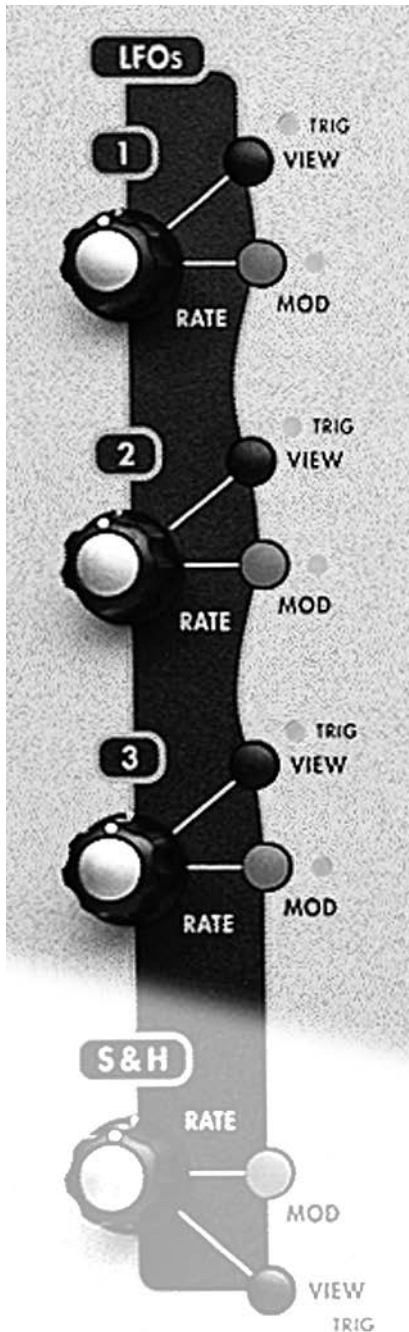

As mentioned earlier in this manual, a Low Frequency Oscillator (LFO) primarily provides periodic (repeating pattern) modulation to its assigned destination. But an LFO can also produce aperiodic (non-repeating) modulation based on a randomly-generated waveform and a noise source.

Although they are somewhat similar in design to the VCOs, LFOs are **not** intended to be used as audio sources. Therefore, their outputs are not routed to any of the A6's audio paths. Instead, LFOs are routed to other elements of the sound as a mod source, so while you can't hear them directly, you can hear their effect on other elements of the sound in a modulation path.

In addition, the description of LFO waves bear a striking resemblance to VCO waves. So you may notice that you've seen many of this chapter's diagrams in previous parts of the manual. This is not a *deja vu*, and we'll try to keep the confusion to a minimum.

The most common use of an LFO is for vibrato (VCO frequency or pitch modulation). The mod wheel on the A6 is a perfect example of this as it controls the amplitude (amount) of an LFO that is routed to the frequency of the VCOs. An LFO is often routed to modulate the filter frequency (harmonic modulation) or the any of the amplifiers in the audio path (amplitude modulation, or tremolo): the **PRE FILTER MIX**, **POST FILTER MIX** or the **VOICE MIX** stages.

The LFO section of the A6 also contains a special aperiodic mod source called sample-and-hold – **S & H** on the front panel – which we'll get into shortly.

LFO PARAMETER DESCRIPTIONS

The parameters of the LFOs are described below. Parameters marked with a ✪ are also mod destinations – they can be modulated by another source. You can experiment with any of the parameters by pressing the **VIEW** button or turning the **RATE** knob on any of the three LFOs. Then use the soft knobs and buttons below the display to select a specific parameter.

Tip: *Tabbing* feature: You can select any parameter simply by turning its corresponding soft knob, but this action also changes the parameter's value which isn't always desirable. If you just want to review the current settings of the LFO parameters without changing anything, you can select a parameter **without** changing its value by pressing its page's soft button. For LFO pages (like the Envelopes) pressing a soft button once selects the page, pressing it again selects the parameter to the right of the active parameter in the Parameter Row. Repeated pressings cycle through all parameters from left to right.

WAVE Page

➔ RATE Frequency Select

The speed of the LFO is set with this parameter. This is another LFO parameter that you will use often.

Range: .0076Hz – 25 Hz (131.6 seconds per cycle – 40 milliseconds per cycle)

SHAPE Shape Select

Of the nine LFO parameters, the Shape select is one of the parameters you'll use most often when editing an LFO. You have the option of selecting from among four periodic waves (sine, triangle, square/pulse and sawtooth) and two aperiodic waves (random and noise).

BASIC LFO WAVESHAPES

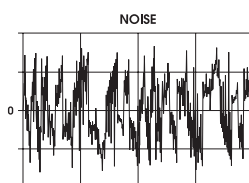
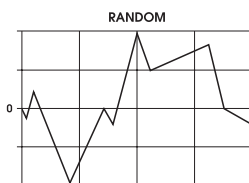
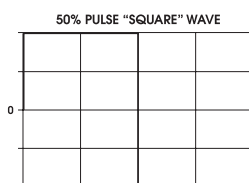
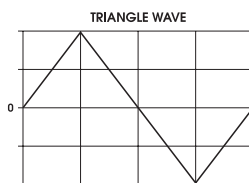
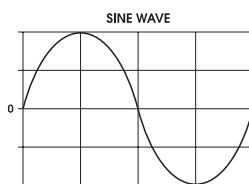

When depicted graphically, these waveforms appear very much like their names imply, and you select a particular waveform based on the type of modulation required.

SINE and TRI

The sine wave produces a smooth rise and fall which is well-suited for most vibrato applications. The triangle has a similar smooth rise and fall but with a sharp "peak" (on the positive side of the wave) and sharp "trough" (on the negative side). Triangle waves are also adequate for vibrato, especially at low amplitude settings where the effect of sharp peaks and troughs aren't as noticeable.

SAW

The sawtooth wave combines the characteristics of the triangle and pulse waves. An "up" or positive sawtooth wave has a smooth rise with a sharp peak that immediately drops and starts its rise cycle again. A "down" or negative sawtooth falls, then immediately rises up to the start level. Unlike the oscillators which have positive/negative sawtooth waves to select from, in the LFOs the up/down characteristic of the wave is set by the **PWIDTH** parameter explained on the next page.

PULSE

In contrast, the pulse wave is characterized by abrupt or instantaneous rise and fall, producing a "push-pull" or "high-low" effect. When its width is set to a square wave (50%) and routed to the VCOs, for example, it is well-suited for trills. Careful adjustments to its amplitude actually allow you to "tune" the wave's high-low movement to specific musical intervals.

RANDOM or NOISE

The random wave can be characterized as a wave that sounds like it's jumping all over the place, especially at high amplitude levels. The noise wave is an "ultra-random" wave that has a much higher frequency than the random wave, sounding like hiss.

➔ **DELAY Delay Time**

This parameter sets time that elapses before the LFO begins its oscillation. During this time delay, the LFO is inactive.

Range: 0 – 131.075 seconds, adjustable in increments of 2 to 10 milliseconds.

➔ **PHASE Initial Phase**

This parameter sets the *initial phase portion* where the LFO waveform starts. Here's how an LFO's wave phase is described and adjusted:

One cycle of an LFO's wave equals a 360° "phase" (cycle). Under normal circumstances, an LFO's wave will rise at the start of its oscillation (the initial phase) at the neutral point of 0°. This parameter allows you to instruct the A6 to start the LFO – its initial phase – at later points of the waveform. For example, if you wanted to start at the peak of the wave, set this to 90 degrees.

Range: 0.00 – 360.00 degrees in increments of .01.

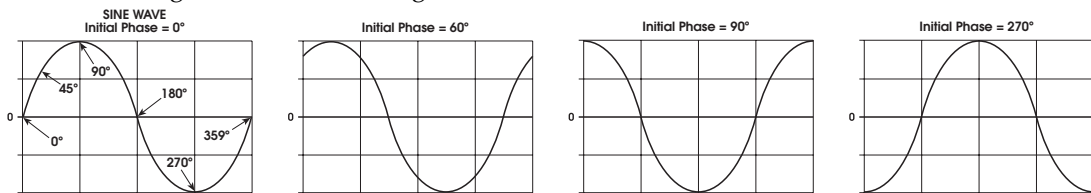

➔ **WIDTH Wave Width**

You can alter the width of the triangle and pulse waves which allows for variations in the way these waveshape rise and fall. A width adjustment alters the duty cycle – the positive portion of the wave – relative to the negative side and gives the wave a significantly different property when modulating a destination.

Range: 0.00 – 100.00% in increments of .01%

Pulse wave with adjustment range:

50% duty cycle (square wave) to 5% (narrow pulse)

LFO PULSE WAVES

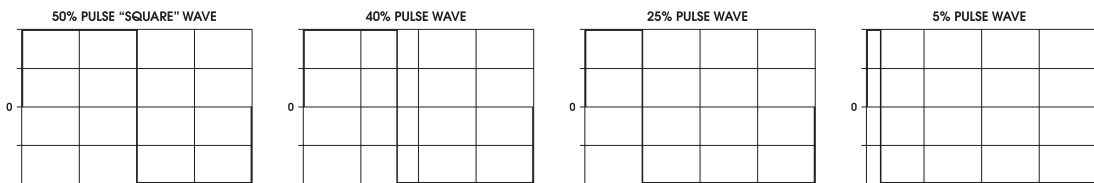

Triangle wave width adjustment range:

100% duty cycle produces an UpSaw wave, 50% duty cycle produces a symmetric or triangle wave, 0% duty cycle produces an DownSaw wave.

If the wave type is **SAW**, below 50% produces a DownSaw, above 50% an UpSaw.

LFO TRIANGLE, UP SAWTOOTH and DOWN SAWTOOTH WAVEFORMS

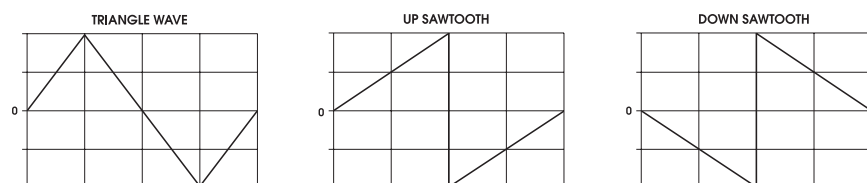

➤ **OFFSET DC Offset**

This parameter allows you to shift (“offset”) the zero amplitude reference for the LFO wave. This means that, as depicted in the graphs below, you can move the zero line – the point of a wave where it is neither positive or negative – up or down. This is the equivalent of adding a fixed direct current voltage to an alternating wave.

This parameter gives you the ability to add a pitch bend to a vibrato (if the LFO is modulating an oscillator) or add a volume increase to a tremolo (if the LFO is modulating a VCA).

Range: -100.00 – +100.00 in increments of .01

LFO OFFSET

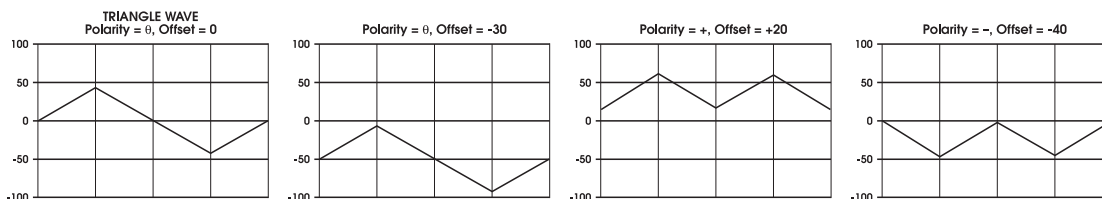

➤ **LEVEL Amplitude Select**

This is the initial amplitude of the LFO. The term *initial* is used because this parameter can be modulated by another mod source. Therefore, this parameter sets the LFO’s amplitude before modulation occurs, if any. If no mod source is routed to this parameter, its initial level is also its final level. (Note in the illustration at right that levels above 50 produce clipping.)

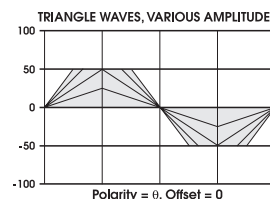

Range: 0 – 100.00 in increments of .01.

Note that the LEVEL of the LFO itself and the LEVEL on a receiver's MOD page are separate, and interact with each other. Think of this as the "send" and the level on the oscillator or filter as the "receive".

➤ **POLAR Polarity**

Where the DC Offset parameter (OFFSET, above) allows you to shift the zero amplitude reference for the LFO wave, this parameter defines which side of zero the wave will stay on. It simply sets the LFO’s *polarity* – does it produce a positive voltage, a negative one or both?

- BI-POL = center zero: this is a standard “bi-polar” wave – the LFO’s voltage oscillates both positively and negatively around the zero reference
- POS- = positive: LFO voltage oscillates above the zero reference only
- NEG- = negative: LFO voltage oscillates below the zero reference only

LFO POLARITY

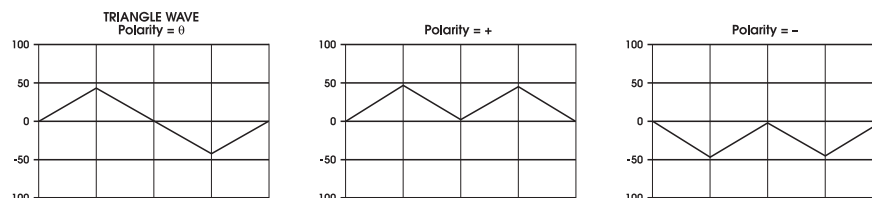

TRIG Page

As important as **how** an LFO operates is **when** it begins to oscillate. It is usually assumed that an LFO starts when a key is played or MIDI Note is received, or at the end of the Delay stage. All three of these scenarios are correct, but more accurately, it is the **trigger** that originates from the keyboard or MIDI that starts the LFOs' oscillation. This page allows you to do more than that.

The TRIG page in the LFO section is mostly about allowing you to start the LFO's oscillation from something other than a key hit. None of the variables on this page will take effect until the VOXTRG parameter is set to ON TRIG. Its default setting is ON VOX which initiates the LFO when a voice is activated from the keyboard or MIDI, as is customary.

SOURCE Trigger Source

This menu is probably familiar to you by now—it contains the 79 Mod Sources covered in Appendix B.

Depending on the source, you may set an LFO to start only above or below certain key ranges, or when a particular envelope stage is set, or in response to a MIDI message. The possibilities are huge.

LEVEL Trigger Input Level

This sets the threshold level for the trigger, up or down. A setting of zero is in the middle. For many trigger sources, the level must be positive to achieve a trigger. But for others, you may need to reduce it so that the LFO is triggered only when you want it to be.

Range: ± 100.00 in increments of .01.

TYPE Trigger Type

This sets the conditions or rules under which a trigger will occur as the input source crosses the threshold level. See page 143, the POLAR parameter, for explanations of the values for Trigger Type. The illustrations on pages 155-157 in the Modulation section will also help you understand the meaning of NEGATIVE, POSITIVE, BIPOLAR, ABS NEGATIVE, ABS BIPOLAR, and ABS POSITIVE.

ENABLE Trigger Enable (ON or OFF)

Soft Knob #6 of this page turns the whole Trigger source for the LFO on or off. When it is ON, the TRIG LED on the top panel (next to the LFO's VIEW button) will light.

Even if TRIG ENABLE is ON, the LFO will not be triggered from the selected trigger SOURCE unless VOXTRG is set to ON TRG. The TRIG LED doesn't have to be on for the LFO to be triggered by the standard voice/key on trigger path.

VOXTRG LFO Trigger from Voice (ON VOX or ON TRG)

Soft Knob #7 of this page determines whether the LFO will start from its default source (ON VOX, meaning when a key or MIDI input triggers the voice) or from the trigger source chosen by Soft Knob #1 on this page.

FREERN LFO Freerun (ON or OFF)

Soft Knob #8 of this page determines whether the LFO will always start at the beginning of its cycle when it receives a trigger (Freerun OFF), or simply keep oscillating and not restart when it receives a trigger.

SYNC Page

This page allows you to synchronize the LFO's frequency with the A6's Master Clock, or with an external MIDI clock. This is a very useful function when you need the LFO to be in sync with the arpeggiator, the sequencer or received MIDI Timing Clock signals.

SYNSRC Synchronization Source

| | |
|-------|--|
| LOCAL | the selected LFO runs independently of the Master Clock at a speed determined by its RATE control. |
| CLOCK | the selected LFO is slaved to the A6's Master Clock, at a multiple determined by the PRDSIZ parameter (see below) |
| MIDI | the selected LFO is slaved to the incoming MIDI Clock, also at a multiple determined by the PRDSIZ parameter |

PRDSIZ Period Size

In order to allow different LFOs to run at different multiples of the incoming clock, **PRDSIZ** allows you to designate the number of clock ticks per period of the LFO. Higher values of this will make the LFO run slower (to the point where you may not notice the LFO moving at all); low values are common for most applications.

Note: The A6's internal clock and MIDI are both based on a 24 ticks-per-quarter note. So, if you select a period size of 24, the LFO will repeat once per quarter note.

Range: 2 – 11904 ticks (31 bars).

MOD Page

This page and its parameters should be very familiar to you by now. You choose a **SOURCE** from the list of 71 possibilities, set its **LEVEL** and **OFFSET** if desired, **ENABLE** it (which can be done from the LFO's top-panel MOD button or from Soft Knob # 5) and send it to its destination:

| | |
|-------------|---|
| FREQUENCY | if you want to change the LFO's speed or rate |
| DELAY | if you want to change the delay before the LFO starts |
| AMPLITUDE | if you want to change the LFO's level |
| PHASE | if you want to change the place in the wave where the LFO will start |
| PULSE WIDTH | if the LFO's WAVE is a square or triangle want to change its width (this variable will do nothing if the WAVE is set to Sine, Sawtooth, Random or Noise). |
| OFFSET | if you want to change the DC offset of the LFO. |

Tip: To have an LFO send controlled by the Mod Wheel, note that it's usually better to assign the Mod Wheel to the **receiver** (for example, MOD 1 of OSC 1) than it is to assign it to control the **AMPLITUDE** of the LFO on this MOD page. This is because the **CROUTES** section pre-routes certain controllers to certain modulation destinations. See Chapter 9 for more details.

USING LFOs AS A TRIGGER SOURCE

While LFOs rely on a trigger source to start (unless they're in Freerun mode), they themselves can also be trigger **sources**. Chapter 6 on envelopes covered some of the triggering capabilities of the LFOs' parameters. As an example, an LFO can be configured so that a trigger is generated every time its wave reaches a certain level. This can be used to trigger an envelope, another LFO, the sequencer or

arpeggiator, and many more. We'll cover more about this in Chapter 9, **The A6 Modulation Matrix**.

SAMPLE AND HOLD

Sample and Hold is a specialty mod source that generates its modulation by "sampling an input". This means that a sine wave, as an example of the input, is *sampled* – a reading of the sine wave's **current amplitude** is taken at regular intervals, the amplitude is *held* for a period of time – and the result is output as a mod source. So, the output of the S & H module, instead of a sine wave, would be a series of "steps". The amplitude of those steps at any given time depends on the relationship between the sampling clock speed and the rate of change of the wave being sampled.

The sampling is usually accomplished by an LFO whose speed is controlled by the **S & H RATE** knob. This LFO only produces a pulse that is used to sample the waveform or other input you select as a source in the display.

Each **sample** represents an amplitude value that the **RATE** LFO will **hold** until the next sample is taken. Depending on the **RATE** setting, this "hold time" could be just a few milliseconds to several seconds in duration.

In the following illustrations, the same sample rate is used to sample two different inputs, a periodic sine wave and an aperiodic noise source. Notice that the resulting output from the sine wave is *symmetrical*: it has an even or regular rise and fall pattern that imitates the uniform shape of the sine wave. The noise input, on the other hand, is a random input and produces a corresponding random output. The latter is what most people think of as a classic sample and hold modulation source.

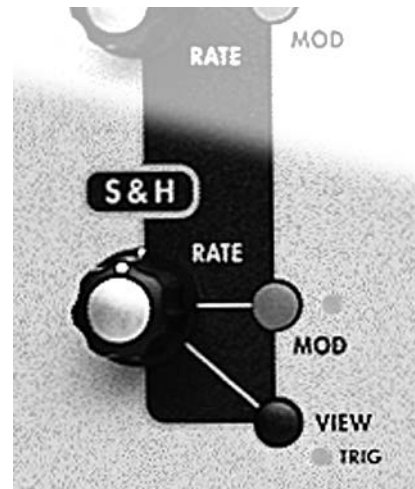

SAMPLE and HOLD

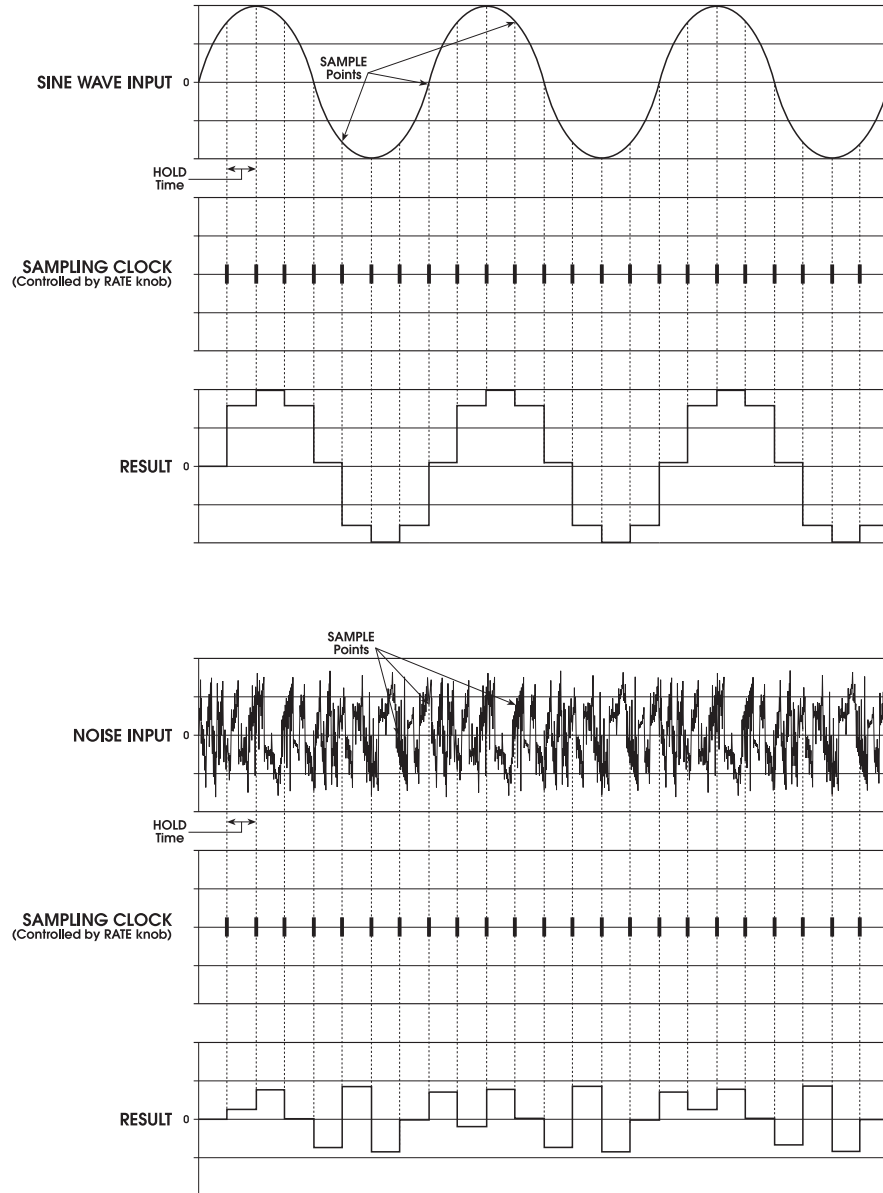

In both examples, the **RESULT** is the output of the Sample and Hold generator and will modulate the selected destination when **S & H LEVEL** is used as a mod source.

PROCESS MODULE



The **PROCESS** module contains the Tracking Generator and the Engine Optimizer.

TRACKING GENERATOR (TGEN)

The Tracking Generator is used to scale a modulation source. It allows you to "redraw" any modulation source to your own custom curves. For example, normally you could modulate the level of a sound using velocity; the harder you play, the louder the sound gets. If the amount of change in volume is equal to the change in velocity, this would be called linear control (and you wouldn't need the

Tracking Generator). However, if you set the Tracking Generator's input to **VOX KEY ON VELOCITY**, and then routed the output of the Tracking generator to **Envelope 3's LEVEL**, you can make your own customized "map" of the control velocity has over the sound level. You could even make it turn back on itself—for example, make it loud at both very high and very low velocities, and softest at average velocities.

When you look at the **TGEN** display, you're looking at a classic "X-Y" axis. The input is on the X axis, from left to right, low values to high values. The output of **TGEN** will be according to the Y axis, from up to down. The Tracking Generator divides the range of the input into a maximum of 16 points or *stages*, each of which can be set to a value between +120 and -120. If you boost the value of one of the lower points, you can make the input more sensitive in its lower register. By creating a non-linear curve, or using one of the preset curves available in the Tracking Generator, you can scale the velocity's control over the sound's volume just the way you want.

Track Gen Level and Track Gen Step



TRACK GEN LEVEL appears as one of the modulation sources in every **MOD** menu. As the input to the tracking generator rises and falls, it scales its output linearly between stages according to the level you set for each stage. For example, if the Pitch Bend wheel is the TrackGen source, and stage 15 is set to +90 and stage 16 is set to +120, at the top 1/16th of the Pitch Bend range the output of the Tracking Generator will rise smoothly, from 90 to 120.

When **TRACK GEN STEP** is chosen as a mod source, the Tracking Generator's output is stepped. This means that instead of scaling the input linearly from stage to stage, the input is kept at each stage's value setting until it goes beyond the following stage's value setting, at which point it jumps to that setting. In the example above, as you raise the Pitch Bend wheel to the top, it would jump suddenly from 90 to 120 with no interpolations in-between as it would with **TRACK GEN LEVEL**. This feature is useful in creating "mini-sequences" if the modulation destination is an oscillator frequency and the Tracking Generator's input is an LFO using an "up sawtooth" as its waveform.

Tip: The Tracking Generator can be used to turn a variable control, such as the Mod Wheel or velocity, into a switch by setting all of the points to 0 except the highest one. Only near the maximum input will anything other than 0 come out of the Tracking Generator. Note that this doesn't keep you from using the Mod Wheel directly at the same time for more gradual functions. For example, the Mod Wheel could be used to gradually bring in vibrato from an LFO, and at the very top of its travel the Analog Distortion could suddenly be switched on.

TRACKING GENERATOR PARAMETER DESCRIPTIONS

The A6 has a 16-stage (maximum) Tracking Generator for each voice. The parameters are described in detail below.

| SOFT KNOB  | 1 | 2 | 3 | 4 | 5 | 6 | 7 | 8 |
|---|--------|-------|--------|--------|--------|-------|--------|----|
|  PAGE TAB | | | | | | | | |
| OUTPUT | INLVL | STAGE | QUANTZ | SIZE | ENABLE | CURVE | OUTLVL | -- |
| INPUT | SOURCE | | LEVEL | OFFSET | ENABLE | | | |

| DISPLAY PAGE | PARAMETER DISPLAY | OPTIONS or RANGE | DESCRIPTION | |
|--------------|-----------------------------|--|---|---|
| OUTPUT | INLVL Input Level | -100 ... +100 | This "sets the X point" of the Tracking Generator. It defines what input level will be affected by the current STAGE (see below). Note that the bar in the display moves from left to right as this is changed, but an Input Level of a stage cannot be moved lower than the stage below it or higher than the stage above. | |
| | STAGE Stage selection | 1 ... 16 | This is effectively the "cursor" of the display, allowing you to select any of the 16 stages for editing. The number of the currently-selected stage will be shown above STAGE and its bar will blink on and off. | |
| | QUANTZ Quantize | OFF ... ON | This determines whether the output of the tracking generator will be quantized to a specific multiple or fraction of the input (-120 S to +120 S), or output a particular value (-100.00 to +100.00) | |
| | SIZE TGen Size | 2 ... 16 | Sets the number of stages in the Tracking Generator. More stages give more detail, but are also more complex to program. | |
| | ENABLE | OFF ... ON | Turns the output of TGEN on or off. | |
| | CURVE | LINEAR EXP 1,2,3 LOG 1,2,3 SCURV1,2 | | This recalls several preset curves for you to use as starting points for editing. |
| | OUTLVL TGen Output Level | -120S - +120S (if quantized) -100 ...+100 (if not) | | Sets the output level of the currently-selected stage of the tracking generator. |

| DISPLAY PAGE | PANEL LABEL | PARAMETER DISPLAY | OPTIONS or RANGE | DESCRIPTION |
|--------------|-------------|-------------------|--|---|
| INPUT | — | MOD SOURCE LIST | Any of the A6's 79 modulation sources. | Use soft knob 1 to scroll through the list of possible sources as input for the Tracking Generator. |
| | — | LEVEL | -100 ... +100 | This parameter sets the amount of input that will go into the Tracking Generator. Keep in mind that negative values invert the action of the selected source. For example, if Velocity is the source and a negative value for LEVEL is used, playing harder will send to lower stages of the Tracking Generator. |
| | — | OFFSET | -100 ... +100 | This parameter sets the offset for the selected modulation. |
| | — | ENABLE | OFF, ON | This parameter is used to turn the Tracking Generator outputs on or off. |

ENGINE OPTIMIZER

The Engine Optimizer can improve how your patch responds to changes in amplitude, filter or pitch. In the vast majority of cases, the patch will sound best if the Optimizer is left at the `NORMAL` setting. This parameter is stored separately per program.

To get to the Engine Optimizer, press the **PROCESS** button and select the `ENGINE OPTIMIZER` from the menu and hit soft button 1 (or just hit the **PROCESS** button again). From here you can select optimization options for the Oscillator and Filter chips.

The Optimizer can be used to improve how certain patches sound with respect to transients. For example, for a kick drum, the filter optimizer set to `FAST PERCUSSION` should make it sound punchier, with a snappier attack. For a pad-type sound, the `WARM PADS DARK BASS` setting should make it sound warmer and cleaner.

The `NORMAL DEFAULT` settings should be just fine for most patches. Unless you see some improvement using the optimizer, just leave it on `NORMAL DEFAULT`.

ENGINE OPTIMIZER PARAMETERS

| DISPLAY PAGE | PARAMETER DISPLAY | OPTIONS or RANGE | DESCRIPTION |
|--------------|--|----------------------------|---|
| ENGINE | OSC Oscillator Engine Optimizer | | Selects Engine Optimizer settings for the Oscillators. |
| | | NORMAL | This is the default setting. It is suitable for the vast majority of sounds that the A6 produces. |
| | | FAST PITCH CHANGES | This setting is suitable for programs that require extremely fast changes in Oscillator frequency. |
| | | SMOOTH PITCH CHANGES | This setting is suitable for programs that require extremely smooth Oscillator pitch or PWM changes. For example, it can be used to smooth out a sine or triangle wave LFO applied to the Oscillators. |
| | | SUPER SMOOTH | This is an even smoother setting for the Oscillators. This setting should only be used in cases where extremely smooth Oscillator pitch or PWM changes are required. This setting should not be used for percussive sounds. |
| FILTER | Filter Engine Optimizer | | Selects Engine Optimizer settings for the Filters. |
| | | NORMAL | This is the default setting, suitable for the vast majority of sounds that the A6 produces. |
| | | FAST PERCUSSIVE | This setting is suitable for programs that require extremely fast filter sweeps. For example, many bass drum sounds are made by quickly sweeping a self-resonant filter. This setting is ideal for that case. |
| | | WARM PADS DARK BASS | This setting is suitable for programs where an extremely smooth filter transition is required. Examples of this include warm pads and dark basses. |
| | | MEDIUM PERCUSSIVE | This is an intermediate setting between NORMAL and FAST. |

PROGRAM FUNCTIONS PART 4: THE ANDROMEDA'S MIXING SYSTEM

One of the most useful and exciting features of the A6 is its ability to mix sound signals in a multitude of ways. Having a wide choice of *audio paths* – routes that the oscillators and other sound sources can take as they make their way through the A6 – provides another set of power tools that you can use to create sounds.

The **PRE FILTER MIX**, **POST FILTER MIX** and **VOICE MIX** are modules used to blend the A6's sound for the Programs. **VOICE MIX** is also important when setting the levels of different Mix Channels in Mix Mode. But for now, we'll focus our efforts on Program functions.

PRE FILTER MIX/POST FILTER MIX

The **PRE FILTER MIX** and **POST FILTER MIX** modules are used **in conjunction** to mix the levels of the A6's sound sources, the Ring Modulator of each voice, and the two Filters. **PRE FILTER MIX** controls the A6's sound sources going into the Filters and **POST FILTER MIX** handles the Filter outputs plus several unfiltered signals going into the VCA controlled by Envelope 3.

PRE FILTER MIX OVERVIEW

The **PRE FILTER MIX** module contains six knobs that control the **initial output levels** of their respective sound sources before they are processed by the Filters and then have their **final output levels** set in **VOICE MIX**. It is the **PRE FILTER MIX** module that you use to mix the relative output levels of the VCOs (and add in their sub-oscillators if desired), select and mix in a noise source or external audio (but not both), mix in Filter Feedback, and set the level of the Ring Modulator. All of these sound elements can be mixed into a Program at the same time.

You can route the "output" of **PRE FILTER MIX** – any combination of the VCOs (**OSC 1** and **OSC 2**) plus their sub-oscillators (**SUB OSC**), the Ring Modulator (**RING MOD**), Noise/External Audio (**NOISE EXT**) and **FILTER FEEDBACK** from the **POST FILTER MIX** – in a number of different ways:

- into **FILTER 1** only
- into **FILTER 2** only
- into both Filters in **parallel** – each Filter processes the **PRE FILTER MIX** signal independently and at the same time
- into both Filters in **series** – the output of **PRE FILTER MIX** goes first into **FILTER 1**, then into **FILTER 2**, effectively permitting the "filtering of a filter"

The Ring Modulator is especially interesting in that you can route it into the Filters as above, bypass the Filters altogether (it has a direct route into **POST FILTER MIX**) or have both the Filtered and unfiltered signals at once. See the topic on the following page for the complete story.

Note that **all audio sources are available at the same time**, with the exception of Noise or External audio – you must select one or the other.

In addition, each level control in the **PRE FILTER MIX** has its own **MOD** button for controlling levels from any of the modulation sources. You can modulate the levels of the VCOs and their sub-oscillators, the level of the Ring Modulator and the level of the Noise Generator/External Inputs.

PRE FILTER MIX OPERATION

OSC and SUB OSC Controls

The output levels of both VCOs going to the Filters are controlled by their respective **OSC 1** and **OSC 2** knobs. Each VCO also provides a sub-oscillator output and its level is controlled by the **SUB OSC** knob. Each sub-oscillator outputs a square wave from its respective VCO, tuned one octave below its **SEMITONE** setting.

RING MOD Control

Each voice's Ring Modulator is simple in its operation but provides a wealth of new timbres and textures that can be used on their own or mixed in with the VCOs' unmodified waves.

The **RING MOD** knob controls the output level of the Ring Modulator into **FILTER 1**, **FILTER 2** or both. The Ring Modulator's output is also routed directly to the **POST FILTER MIX**, bypassing the Filters. This dual audio path allows you to filter the Ring Modulator's output, feed it directly to the outputs with no filtering, or both. We'll detail how to use this feature of the A6 on the following page.

RING MOD Operation

The A6's Ring Modulator takes the waveforms of the two VCOs and multiplies them by each other. The keyword here is **multiplies**: notice that we didn't say **modulate**. The A6 does allow you to FM-modulate one VCO by the other – covered on page 109 – which produces different results.

When two waveforms are multiplied together, the result is a new waveform that is composed of two frequencies: the **sum** of the two original waveforms' frequencies and the **difference** of their frequencies. In the following illustration, we start with two sine waves, one at 300Hz and one at 1,200Hz. When multiplied, the resultant waveform is composed of a 1,500Hz wave (300 + 1,200) and a 900Hz wave (1,200 - 300).

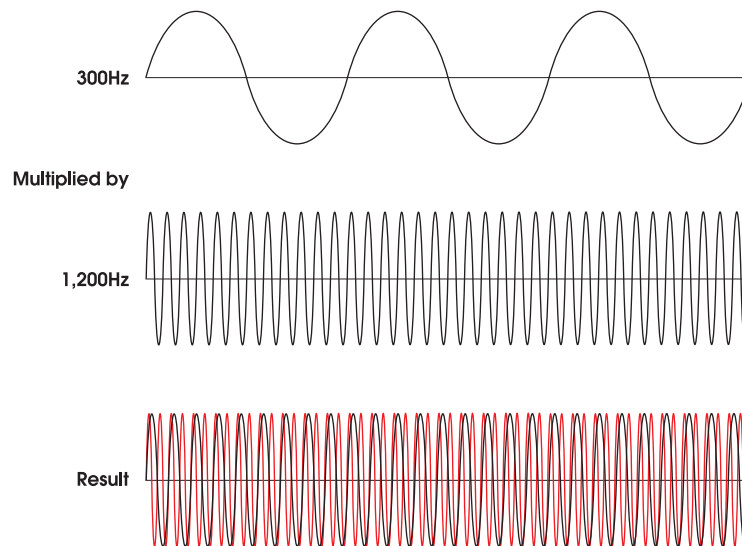

Note that this example uses two **sine** waves. When experimenting with the Ring

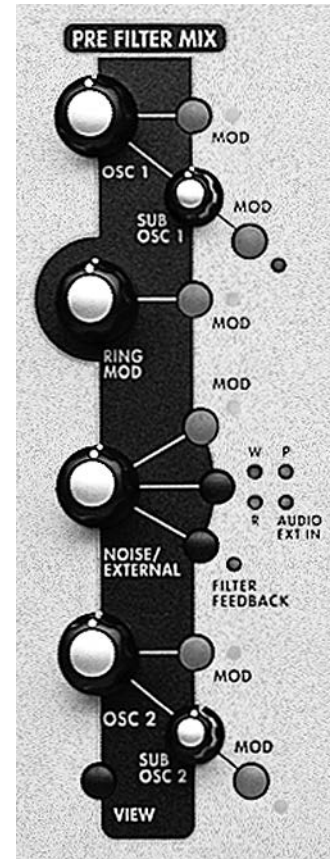

Modulator, using the sine waves of **OSC 1** and **OSC 2** is a good place to start because sine waves have no harmonics. This will allow you to hear the Ring Modulator produce a waveform with the least complexity.

Different results are obtained by using two square waves or two sawtooth waves as these waveforms contain **numerous harmonics** which are also multiplied together. Next try multiple waveforms in each VCO: **SAW** plus **TRI**, **SQR** plus **TRI**, **SQR** plus **SAW** or two square waves with different pulse widths. While you're testing out different pulse widths, you may also want to add pulse width modulation (press the **PWM** button and make changes to the assigned LFO's square wave) to hear what happens.

You may also want to experiment with different VCO tunings – experiment with the **SEMITONE**, **CENTS** and **FINE** knobs. Try modulating the frequency of a VCO (or both of them) with a slow LFO or **ENV 1 (PITCH)**.

NOISE/EXTERNAL Control

The **NOISE/EXTERNAL** knob controls the initial level of three varieties of **NOISE**, the level of the external **FILTER AUDIO INPUTS** and the internal **FILTER FEEDBACK**. Each of the four audio sources are selected in turn (or turned off) by repeatedly pressing the input button; the current Noise/External source is shown by LEDs on the top panel and in the display. Only one source can be selected at a time. But Filter Feedback is on its own switch, and when this switch is on Feedback is added at a fixed amount to the **NOISE/EXTERNAL** input amplifier controlled by the **NOISE/EXT** knob.

NOISE

The A6 provides a single noise generator that is available to all voices. Noise is produced by circuit that outputs nearly all audible frequencies at once, called *wideband* audio. The result is an unpitched signal that sounds similar to the "static" you hear on a radio when it's tuned between two stations.

Noise is often used to simulate wind, thunder and explosions. When used subtly, noise can embellish musical sounds created with the VCOs by adding breath effects to brass and woodwinds, for example.

Noise is generated in three "colors": white, pink and red. These are names that refer to the frequency range of the noise signal. White noise (indicated by the **W** LED on the front panel) selects the **entire range** of noise at identical levels regardless of frequency. White noise sounds the brightest and fullest of the three. Pink noise (indicated by the **P** LED) reduces the high frequencies and sounds less bright than white noise. Red noise (the **R** LED) has even more high end removed and sounds the least bright of the three noise sources.

Pressing the button to the left of these LEDs switches among the three noise sources plus **AUDIO EXT IN**, described next.

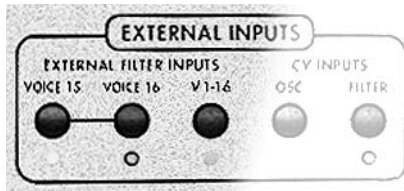

AUDIO EXT IN

You can process external audio sources through the A6. Examples of audio sources you can use include an electric guitar, a high-impedance microphone, a digital sampler, an audio CD player or cassette player, just to name a few.

You may want to process your external audio by the A6's Filters. And since the Filters can be modulated, you can also shape the external source by an envelope and add a host of other mod sources if needed.

EXT FILTER INPUTS/ V 1-16 Jack

V 1-16 Button

The **V 1-16** jack on the Andromeda's back panel is a high-impedance input that routes a *mono* or single-channel external audio source to all 16 of the A6's Voices. This means that you can process a mono signal **polyphonically** through the A6's filters, complete with all of the modulation normally available to the Filters: envelope shaping, LFOs and the rest of the A6's 79 mod sources.

To activate this function, press the **V 1-16** button on the **EXTERNAL INPUTS** module. When you do this, a number of parameters will be automatically set to enable the audio path. The **AUDIO EXT IN** input will be selected, the **AUD IN** switch will be turned on, and the **NOISE** level will be set to 100 in **PRE FILTER MIX** (since this is the path that the External Input uses). Use the **NOISE/EXTERNAL** knob to adjust the level of this signal.

EXT FILTER INPUTS/VOICE 15 and VOICE 16 Jacks

VOICE 15 and VOICE 16 Buttons

The **VOICE 15** and **VOICE 16** jacks are high-impedance inputs that route a stereo or two single-channel external audio sources to Voice 15 and Voice 16. These inputs differ from the **V 1-16** jack in that, when activated, the Voice 15 and Voice 16 circuitry inside the A6 are reserved for external audio processing and are not affected by the keyboard, received MIDI Notes or any other trigger sources.

To activate this function press the **VOICE 15** and/or the **VOICE 16** buttons on the **EXTERNAL INPUTS** module. When you do this a number of parameters will be automatically adjusted so you can immediately hear the audio path. The **KBD MODE** will be set to **MONO**, (voice 15 or 16), and **UNISON X** will be turned off.

FILTER FEEDBACK

A little trick that was used in the days of modular synthesizers to achieve a gritty, nasty sound was to connect the output of the filter module back into the mix module. Since the mix module is normally routed to the filters to begin with, a feedback loop was created. (MiniMoog users might remember this capability by connecting the Mini's headphone output to the auxiliary audio input).

The A6 pre-wires this circuit for you internally: no patch cords required. Press the **FILTER FEEDBACK** button to enable this function and use the **NOISE EXT** knob to control the feedback level. Please note that the level settings of the Filters – **FILT1 LP**, **FILT1 HP**, **FILT1 BP** and **FILT2 LP** – also affect the feedback. Use these five knobs in conjunction to obtain the feedback you want.

Signal Routing through the Filters

The **PRE FILTER MIX** outputs of **OSC 1** and **OSC 2** (along with their respective **SUB OSC** signals), the **RING MOD** and **NOISE EXT** can be routed through the A6 using the following procedures.

Please note that the **PRE FILTER MIX** output **always** goes to **FILTER 1** unless, of course, **FILTER BYPASS** is on. The following procedures will inform you how to turn the Filters on or off using their respective level knobs, as well as other Filter “mixing” methods you’ll find useful.

Tip: For these examples, you can experiment with any of the components in **PRE FILTER MIX**: the procedures are applicable for any of them or **all** of them, should you need to mix in levels of all four knobs.

For the component you select, turn its knob to its 2 o’clock position. This will give you a moderate output level to work with. If you are trying out the VCOs, you can also mix in their **SUB OSCs** if you like by turning the knobs clockwise.

Check that the **LEVEL** knob in **VOICE MIX** is turned up and adjusted to provide a comfortable listening level.

Last, turn down all the knobs in **POST FILTER MIX** as a starting point. The examples that follow will tell you what knob to use when appropriate.

- To process external audio through **FILTER 1** only, turn up the **FILT1 LP** knob. This causes **FILTER 1** to output its lowpass-filtered signal. To have the Filter output other filtered signals – highpass, bandpass or notch – turn up their respective knobs. (We’ll provide details on these controls under the **Filter Output Controls** topic on the following page.)
To be certain that you’re only hearing **FILTER 1**, make sure that the **FILT2 LP** knob is turned fully counter-clockwise. This shuts off the output of **FILTER 2**.
- To process external audio through **FILTER 2** only, press the **F2 INPUT** button located on the front panel between the two Filters until the **MIX LED** lights. This routes the output of **PRE FILTER MIX** into **FILTER 2**. Then turn up the **FILT2 LP** knob and make sure that all the other knobs in this module are turned down.
- To process external audio through filters in **parallel**, use the first two methods together: when the **MIX** function is active, the output of **PRE FILTER MIX** flows into **FILTER 2** independently of **FILTER 1**. Use the **FILT2 LP** knob to control the level. And since the output of **PRE FILTER MIX** is normally routed to **FILTER 1**, use any (or all) of the **FILT1** knobs to mix in the output of **FILTER 1**.
This functionality of the A6 mixing system provides enormous flexibility: you can independently mix the levels of two Filters complete with their own **RESONANCE** levels, **KEY TRACK** amounts and modulation. You can even assign a different envelope to one of the Filters for independent harmonic shaping.
- To process external audio through filters in **series**, press the **F2 INPUT** button until either the **NOTCH LED** lights or the **BP** (bandpass) LED lights. When either of these two LEDs are on, that means that the respective output of **FILTER 1** will flow into **FILTER 2**. Here are the details:
 - When using **NOTCH** as the input, remember from Chapter 5 that the notch in the **FILTER 1**’s harmonic spectrum is created by using **both** lowpass and highpass filtering together (page 118). The input to Filter 2 is post-fader, meaning that you can turn up the **FILT1 LP** and turn **down** the **FILT1 HP** knob which effectively gives you a “**LOWPASS**” input instead of **NOTCH** as it is labeled on the front panel. Conversely, you can turn down **FILT1 LP** and

turn up **FILT 1 HP**, effectively giving you a “**HIGHPASS**” input to **FILTER 2** instead of a notch.

- When using **BP** as the input to **FILTER 2**, you can invert the bandpass filtering by pressing the **BP INVERT** button in the **POST FILTER MIX** module.

RING MOD Signal Routing

The signal routing of the Ring Modulator has a unique feature that allows you to bypass the Filters while still routing the **RING MOD** signal as in the above examples. This allows you to hear the filtered and unfiltered Ring Modulator simultaneously. You can't do that with the other components of **PRE FILTER MIX**.

- To hear the Ring Modulator in its purest form, turn all four knobs in **PRE FILTER MIX** fully counter-clockwise. This turns off all of the **PRE FILTER MIX** components going to the Filters.

In **POST FILTER MIX**, press the **RING MOD** button located near the bottom of this module until the LED is off. (If the **OSC 1 SINE** or **OSC 2 SINE** LEDs are lit, press those buttons to turn them off.) This connects the Ring Modulator's output to the **PRE FILTER** knob, bypassing the Filters. Use this knob to control the level of the unfiltered Ring Modulator signal.

Try pressing the **MOD** button and assigning **ENV 1 (PITCH)** to shape the loudness of the Ring Modulator's signal, especially if the Filter Envelope is being used to control the other signals.

- To hear this unfiltered Ring Modulator signal along with filtering, raise the **RING MOD** control in the **PRE FILTER MIX**. Then follow one of the procedures on the previous page to route the **RING MOD** signal, in parallel, through one or both of the Filters.

POST FILTER MIX OVERVIEW

The **POST FILTER MIX** module contains five knobs that control the output of the Filters going to the **VOICE MIX** plus the unfiltered signal levels of **OSC 1** and **OSC 2 SINE** waves and the **RING MOD** signal.

POST FILTER MIX, like the **PRE FILTER MIX** module, includes a number of **MOD** buttons that are used to route mod sources to their respective destinations. You can modulate the levels of the **FILTER 1**'s lowpass, highpass and bandpass (as well as the inverted bandpass) outputs, and the level of **FILTER 2**'s lowpass output. The **PRE FILTER** knob, which controls the unfiltered levels of **OSC 1/OSC 2 SINE** waves and **RING MOD** outputs, can also be modulated.

POST FILTER MIX OPERATION

The first four knobs in **POST FILTER MIX** are all level controls for the Filters' outputs routed to the **VOICE MIX** as shaped by **ENV 3 (AMP)**. We've already covered the principles of these Filter functions earlier in Chapter 5 under the topics **How Filters Are Designed** (refer to page 117 if you need a review) and **Signal Routing** (see the previous page). We're providing a summary here.

FILTER 1 Controls

The **FILT1 LP** knob controls the level of **FILTER 1**'s low pass filtered signal while the **FILT2 HP** knob controls the level of **FILTER 1**'s high pass filtered signal. Both of these knobs can be used at the same time. When they are, a **NOTCH** filter is produced.

The **FILT1 BP** knob controls the level of **FILTER 1**'s band pass filtered signal. The band of frequencies can be inverted by pressing the **BP INVERT** button.

FILTER 2 Control

The **FILT2 LP** knob controls the level of **FILTER 2**'s low pass filtered signal.

PRE FILTER Output Control

This knob controls the level of three signals – **OSC 1 SINE** (the sine wave output of **OSC 1**), **OSC 2 SINE** (the sine wave output of **OSC 2**) and **RING MOD** (the output of the Ring Modulator) – that are routed directly from the sources to the **POST FILTER MIX**, bypassing the Filters. This direct signal flow provides several distinct advantages when editing Programs, covered in detail earlier in this manual on page 126.

To select any or all of these signals, press the respective button or buttons – all three signals can be selected at the same time. Use the **PRE FILTER** knob to set the initial level. If you want independent envelope shaping of the loudness of these **PRE FILTER** signals, press the **MOD** button and assign an envelope at this point in the mix.

FILTER BYPASS Button

Normally, all audio flowing through the **A6** is routed to **FILTER 1**. And depending on the settings of the **LP INPUT** button and the **POST FILTER MIX** level knobs, **FILTER 2** becomes part of the mix as well. You can, however, bypass both Filters if necessary. Pressing the **FILTER BYPASS** button disconnects both Filters from the audio path: any sound going through the **A6** is untouched. You **must**, however, shape the signal's loudness by **ENV 3 (AMP)** as all audio is hardwired to this envelope.

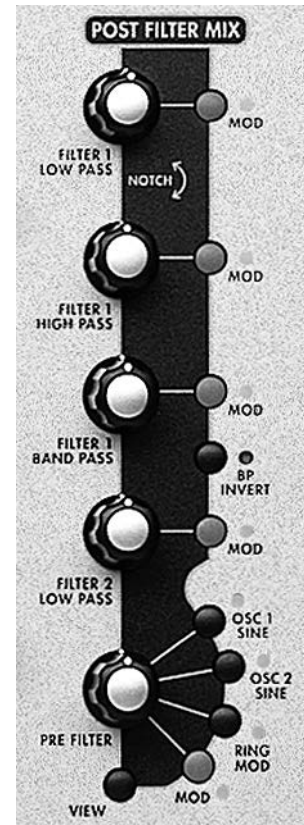

VOICE MIX

The **VOICE MIX** module contains the final mixing stages of the A6. The mixed output of this module feeds the instrument's **MASTER VOLUME** knob on the left of the instrument that controls the final output of the A6.

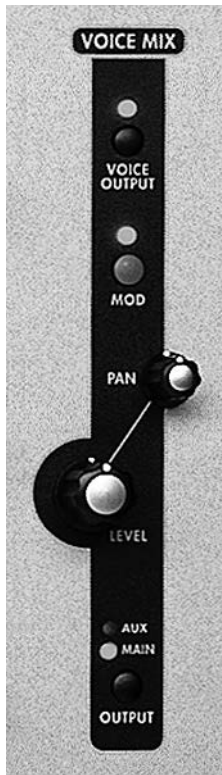

VOICE MIX is where the relative levels and *panning* – the placement of voices left-to-right in the stereo image – are set as part of a Program or Mix. You have a **LEVEL** knob and a **PAN** knob for the back panel outputs: **MAIN (LEFT and RIGHT stereo pair)**, and alternatively an **AUX 1-2** pair. The important concept to understand here is that you are panning the final outputs of the A6's 16 **voices**.

MAIN and AUX outputs

The **LEVEL** knob controls the level of the A6's stereo mix sent to either the **MAIN RIGHT and LEFT** (via the Master Volume control) or **AUX** back panel jacks. An **OUTPUT** switch toggles the output of the current Program or Mix Channel between the **MAIN** and **AUX** jacks. The most important difference between the Main and Aux jacks is that the **EFFECTS** outputs are only routed to the **MAIN** outputs, and the headphones only monitor the **MAIN** outputs. Aux jacks can serve as a separate "dry" stereo output in case you need them. Examples include a send to a stereo monitor mix, a stereo send to an external effects device (EQ, compressor and so forth) or outputs to additional tape tracks, just to name a few.

Note that you can pan the voices hard left or hard right in **MAIN, AUX** or **OFF** and use the corresponding jack for a **mono** signal output.

These settings are **programmable** for each Program and Mix. Just remember that the **MASTER VOLUME** control (on the far left side of the front panel) affects only the Main Output, and it is **NOT** programmable.

Last, the **MOD** button is used to route a mod source to modulate the **PAN** of the Main and Aux outputs. Any of the A6's 79 modulation sources can

be assigned.

Setting Levels in Mix Mode

The ability to set different output assignments, pans, and levels is most useful when the Andromeda is in Mix Mode. For example, you can send Mix Channels with bass programs to the **AUX** outputs, and layer different Mix Channels' outputs in stereo for dramatic effects.

The settings for each Mix Channel's **VOICE MIX** can be set either directly on the Voice Mix controls, or on the **PROG** page in Mix Edit mode using the soft knobs. Level, Pan, and Main/Aux selections made on either display will be shown automatically on the other.

To set the Voice Mix parameters for different Mix Channels, simply use the **MIX CHANNEL SELECT 1/9-8/16** buttons to select the channels you want.

Individual VOICE OUTPUT

The **VOICE OUTPUT** button at the top of the module turns the feed to the individual **VOICE OUTPUT** jacks on and off. It has no effect on the feed to the Main or Aux outputs. Although it may not be obvious from the display, the **VOICE OUTPUT** jacks are affected by the **LEVEL** knob, though not by the **PAN**, since they are monophonic. They are the direct outputs of each of the sixteen hardware voices.

CHAPTER 9:

CUSTOM MODULATIONS

Chapter 5: Program Functions just presented us with a detailed look at the main programmable functions of the A6's modules that comprise a Program: **OSC 1** and **OSC 2**, **FILTER 1** and **FILTER 2**, the **PRE FILTER MIX**, **POST FILTER MIX** and **VOICE MIX** audio mixing modules, plus the modulation source modules of the **LFOs**, **ENV 1**, **ENV 2** and **ENV 3**.

Referring back to **Chapter 2: Playing the A6**, we also covered the performance functions of the A6: how to use the Display, the **CLOCK** module (**SEQUENCER** and **ARPEGGIATOR**), the **MASTER** module (**VOLUME** and **TUNE**), the **KBD MODE** and **PORTA** modules, and the performance wheels, ribbon controller and pedals.

As far as modulation is concerned, **Chapter 6: Modulation and Envelopes**, and **Chapter 7: LFOs, Sample and Hold and Process** covered the most important modulation sources.

So looking at the A6's front panel, it would be easy to conclude that we've covered just about all there is to know about the A6.

Well, not quite. Now we'll explain how the modulation sources can be routed and controlled within a program.

MOD FUNCTIONS OVERVIEW

We've already covered much in the way of modulation when we presented the LFOs and Envelopes topics in Chapter 6. There were also many instances where a **MOD** button was mentioned, if only briefly, as a way to route additional mod sources to the function being discussed. In this Chapter, we'll detail one of the most flexible features of the A6 called the Modulation Matrix. This technology expands the modulation capabilities of the A6 by leaps and bounds.

Where the default and hardwired modulations in the A6 provide the standard, most-used modulations, you can think of the Mod Matrix as a "system of custom mod paths". There will be times that the default mod paths won't be able to offer the kind of modulation you really need to do the job. The Modulation Matrix, which is the engine underneath the **MOD** buttons, permits taking any one of the A6's 79 modulation sources and routing it to any one of 175 destinations. That's 13,825 possible new mod paths. In addition to the standard "hardwired" modulations, there's almost no route you can imagine that can't be implemented if you're creative about it.

Between the many "hardwired" and the 45 custom mod paths available, you have thousands of potential modulations per Program – and they're all programmable.

AVOID DUPLICATION WITH HARD-WIRED MODS

The **MOD** functions are so flexible, they may fool you into using them when one of the pre-wired modulations would be a wiser choice. For example, in Oscillator 1's **MOD** buttons, you can choose **PITCH WHEEL** as the source and **FREQUENCY** as the destination...but you don't need to do that to get pitch bend, because that's already handled by the **PITCH ASSIGN** system above the wheel itself. Similarly, the Mod

Wheel is assigned by default to control the level of **MOD 1** in each oscillator; you don't have to program that. In both cases, you can turn the hard-wired routes off if you wish, but why use up a custom MOD for something that's already there?

PERFORMANCE CONTROL OF MODS

Once you've set up a modulation, you have two options:

1. Have the modulation exist constantly (for example, if you always want vibrato on) or
2. Control the modulation from a performance controller, such as the Mod Wheel, the Ribbon, or a footswitch.

You need to know which option you will use in order to set the parameters correctly. If you choose Option 2, you'll need to learn about the Control Routes section, on page 198.

USING THE MODULATION MATRIX

Conceptually, you can think of the Mod Matrix as a rather large table with the sources listed down the left-hand column and the destinations listed across the top row. This table forms a "matrix" (sometimes called an *array*) of the available sources and destinations. Any source can be paired with any destination, or with multiple destinations. The following illustration shows just a small representation of the entire table of sources and destinations:

| SOURCES | DESTINATIONS | | | | |
|-----------------|-----------------|-------------------|-------------------------|------------------------------|-----------|
| | OSC 1 Frequency | OSC 1 Pulse Width | OSC 1 Square Wave Level | OSC 1 FM from OSC 2 (Linear) | FM fr (Ex |
| LFO 1 Level | | | | ● | |
| LFO 2 Level | ● | | | | |
| LFO 3 Level | | | ● | | |
| Env 1 Level | | ● | | | |
| Env 2 Level | | | | | |
| Env 3 Level | | | | | |
| Env 1 Attack | | | | | |
| Env 1 Decay 1 | | | | | |
| Env 1 Decay 2 | | | | | |
| Env 1 Release 1 | | | | | |

The bullets indicate the intersection of the source/destination pairs that form the mod paths:

- LFO 1 modulates the OSC 2 Linear FM of OSC 1
- LFO 2 modulates the Frequency of OSC 1
- LFO 3 modulates the Level of OSC 1's Square Wave
- Envelope 1 modulates the Pulse Width of OSC 1

Note that this Matrix doesn't appear directly in the display; instead, you have a *target-based* system that shows an individual matrix element when you press a **MOD** button within a module. The MOD displays are all similar to this:

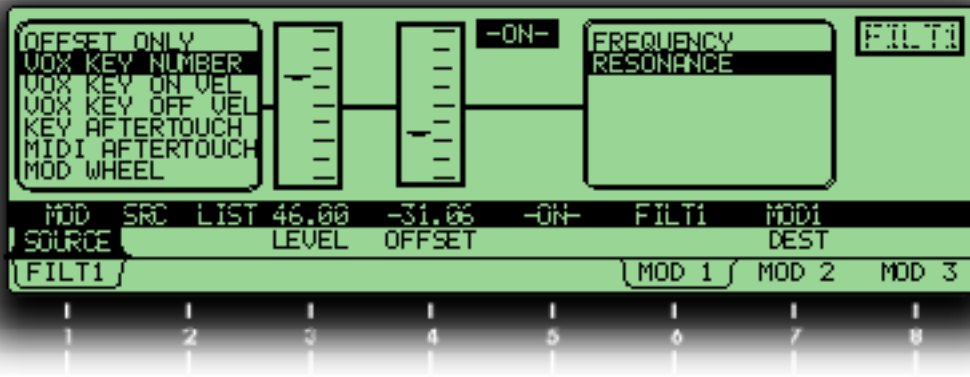

What the MOD display means

The upper right hand corner shows that this is a mod page for Filter 1. By looking at the page tabs and the legend above it, we know we're looking at Mod 1 of that filter. Moving from left to right, we can see:

- the **SOURCE** is **VOX KEY NUMBER**, which means the modulation will rise and fall as you play higher and lower on the keyboard.
- the **LEVEL** is **+46.00**. If it were **0.00**, there would be no modulation unless some other modulator has this level as its target. If **LEVEL** were a negative value, it would invert the modulation (in this case, higher key values would give **LESS** modulation).
- **OFFSET** is **-31.06**. The programmer wanted the "home value" of the modulation to start lower on the keyboard in this case.
- the **MOD** path is **ON**; you can enable and disable this path by pressing the **MOD** key in the module, or by turning soft knob **5**.
- the destination (**DEST**) is **RESONANCE**.

Looking at these elements, you can see that in this program, Mod 1 of Filter 1 is designed to increase the resonance of the filter the higher you play on the keyboard, and decrease it on lower notes. Since the level is positive, this mod path is probably intended to be on constantly...but it's still possible that the amount of resonance could be increased or decreased by still another modulator via **MOD2** or **MOD3**. You'll find out when you check them. The flexibility of the Modulation Matrix may lead to some confusion when you're editing a complicated program, but when you're writing your own program you'll be very glad it's there.

The different ways to modulate a parameter

There are four “levels” of operation that are used to control mod paths in the A6’s Mod Matrix system:

Hardware Mods: The first level uses dedicated front panel controls to control the level of a particular modulation source and is the most visible of the three. First level mods such as PWM and OSC2 FM are commonly used and are easily accessed from the front panel. Other “hardwired” mods include:

ENV 1 AMOUNT which can modulate the frequency of either or both oscillators, **PITCH WHEEL**, also sending to the frequency of either or both oscillators, and **ENV 2 AMOUNT** which can modulate the frequency of either or both filters.

While hardware modulators can be turned off or changed at any time, you don’t have to use a custom mod path for these functions.

Custom Mods (Mod Matrix): Second-level mod paths are the custom paths found in the display only after a **MOD** button is pressed and are not related to a particular source. Instead they can draw on up to 79 Mod Sources which are listed in Appendix B. These “hidden” mod paths involve a large number of sources and destinations that are not that common but are quite useful nonetheless. Examples include using the parameters of a mod **source** as a mod **destination**. You can modulate an envelope – typically a mod source – by selecting many of its parameters as destinations: **LEVEL**, **DELAY** time, **ATTACK** time, **DECAY 1** time, and so on. Another example would be **EFFECTS** parameters: Distortion **SEND** or reverb **SEND**.

Fixed software Mods: Third-level mod paths are also found in the display only. These mods involve **triggers** that are generated by a wide variety of sources including the keyboard, sequencer, arpeggiator and MIDI triggers. Certain other mod sources, such as **CV IN** in the Filter displays, go from a fixed source to a fixed destination, and have no top-panel control.

Control of Custom Mods: “Control Routes” (CROUTES) In addition, control of certain modulation paths can be established in the background using the **CROUTES** (control routes) screen, which essentially “reaches in” to the mod path to modulate its level from a controller or another modulation source. For example, you can control the amount of **MOD 1** modulating Oscillator 2 from the Mod Wheel and/or the Ribbon simultaneously. But if the Ribbon was in the **mod** route and the Wheel was in the **control** route, the Wheel would control how much the Ribbon controlled the modulation of VCO 2.

About the custom MOD paths

A quick look at the A6’s front panel reveals 45 **MOD** buttons strategically placed around the modules. The important concept to understand here is that the function that each **MOD** button is linked to is a **destination**. So when you press a **MOD** button, the function or module where the button is located will be the destination (“what’s being modulated”).

Pressing a **MOD** button causes the screen to display the current mod path along with its current values, as shown on the previous page. If a modulation has not been assigned to this destination, the display will inform you of that (the **SOURCE** will say **OFFSET ONLY**). Either way, use the soft controls to edit the source and adjust the modulation level.

The **MOD** buttons fall into two categories: those linked to a single parameter and those linked to a particular module with several destination parameters to choose from. The following tables will clarify this distinction:

MOD BUTTONS WITH SINGLE DESTINATIONS

| MODULE | BUTTON TITLE | DESTINATION PARAMETER | DESCRIPTION |
|-----------------|------------------------------|-----------------------|--|
| ARPEGGIATOR | SYNC/MOD | TEMPO | modulates the clock rate of the arpeggiator |
| SEQUENCER | SYNC/MOD | TEMPO | modulates the clock rate of the sequencer |
| PORTA | MOD | PORTA RATE | modulates the portamento rate |
| S&H | MOD | SAMPHOLD RATE | modulates the RATE of the Sample & Hold |
| OSC 1 | PWM (Pulse Width Modulation) | OSC 1 Pulse Width | modulates the pulse width of OSC 1's square wave |
| OSC 2 | PWM (Pulse Width Modulation) | OSC 2 Pulse Width | modulates the pulse width of OSC 2's square wave |
| PRE FILTER MIX | MOD | OSC 1 LVL | modulates the output level of OSC 1 |
| | MOD | SUB OSC 1 LVL | modulates the output level of OSC 1's sub oscillator |
| | MOD | RING MOD LVL | modulates the output level of the Ring Modulator |
| | MOD | NOISE/EXT LVL | modulates the output level of the noise module and external input |
| | MOD | OSC 2 LVL | modulates the output level of OSC 2 |
| | MOD | SUB OSC 2 LVL | modulates the output level of OSC 2's sub oscillator |
| EFFECTS | MOD (Analog Distortion) | DISTORT SEND | modulates the level of the Analog Distortion SEND control |
| POST FILTER MIX | MOD | FILT1 LP LVL | modulates the level of FILTER 1's low pass output |
| | MOD | FILT1 HP LVL | modulates the level of FILTER 1's high pass output |
| | MOD | FILT1 BP LVL | modulates the level of FILTER 1's band pass or inverted band pass output |
| | MOD | FILT2 LP LVL | modulates the level of FILTER 2's low pass output |
| | MOD | SIN/RING VOL | modulates the level of the unfiltered signals from OSC 1 and OSC 2's sine waves plus the Ring Mod |

MOD BUTTONS WITH MULTIPLE DESTINATIONS

| MODULE | BUTTON TITLE | DESTINATION PARAMETER | DESCRIPTION |
|------------|-----------------------|---|---|
| LFO1 | MOD | PHASE PULSE WIDTH OFFSET | modulates the PHASE, PULSE WIDTH or OFFSET of LFO 1 |
| LFO2 and 3 | MOD | FREQUENCY DELAY AMPLITUDE PHASE PULSE WIDTH OFFSET | modulates the FREQUENCY, DELAY, AMPLITUDE, PHASE, PULSE WIDTH or OFFSET of each LFO |
| EFFECTS | MOD (Digital Effects) | DFX SEND LEFT, RIGHT, L&R, | modulates the level of the Sends to the left and right side of the Digital Effects module |
| | | PAN | modulates the input pan of any Digital Effect that has a Pan control (parallel configurations) |
| OSC 1 | MOD 1, 2 and 3 | FREQUENCY | modulates the frequency of the oscillator |
| | | SQR WAVE LVL | modulates the level of the square wave output from the oscillator |
| | | PULSE WIDTH | modulates the pulse width of the oscillator |
| | | OSC2->PWM | modulates the amount of pulse width modulation from Oscillator 2 |

| MOD BUTTONS WITH MULTIPLE DESTINATIONS (continued) | | | |
|--|----------------|---|---|
| OSC 1 (cont.) | | OSC2->LIN FM | modulates the amount of linear FM modulation from Oscillator 2 |
| | | OSC2->EXP FM | modulates the amount of exponential FM modulation from Oscillator 2 |
| | | EXT->PWIDTH | modulates the amount of pulse width modulation from the Noise/External module |
| | | EXT->LIN FM | modulates the amount of linear FM modulation from the Noise/External module |
| | | EXT->EXP FM | modulates the amount of exponential FM modulation from the Noise/External module |
| | MOD (OSC 2 FM) | LIN FM | modulates the level of OSC 2 modulating OSC 1's frequency in two different ways |
| | EXP FM | | |
| | | Pulse Width | modulates the level of OSC 2 modulating OSC 1's square wave pulse width |
| OSC 2 | MOD 1, 2 and 3 | FREQUENCY | modulates the frequency of the oscillator |
| | | SQR WAVE LVL | modulates the level of the square wave output from the oscillator |
| | | PULSE WIDTH | modulates the pulse width of the oscillator |
| | | EXT->PWIDTH | modulates the amount of pulse width modulation from the Noise/External module |
| | | EXT->EXP FM | modulates the amount of exponential FM modulation from the Noise/External module |
| FILTER 1 and FILTER 2 | MOD 1, 2 and 3 | FREQUENCY | modulates the frequency of the filter |
| | | RESONANCE | modulates the resonance of the filter |
| ENV 1 ENV 2 and ENV 3 | MOD 1, 2 and 3 | DELAY, ATTACK, DECAY 1, DECAY 2, RELEASE 1, RELEASE 2 | modulates the time of these filter segments |
| | | ENVELOPE LEVEL, SUSTAIN LEVEL | modulates the level of the entire envelope, or the sustain segment |
| | TRIGGER | TRIGGER and RETRIGGER | triggers the envelope in response to the modulation source |
| VOICE MIX | MOD | MAIN OUT PAN AUX OUT PAN | modulates the pan of the Main or Aux stereo outputs |

A FEW GROUND RULES

- The mod paths created from the Mod Matrix are programmable per Program. This means that each of the A6's 128 Programs can have a unique set of custom mod paths, or none at all.
- Therefore, all Mod Routes routings must be written into memory with the **STORE** button, just like any other Program or Mix parameter.
- When there are multiple **MOD** buttons in a module, you can actually assign multiple sources to the same destination. You can also take the same source and route it to different destinations simultaneously.
When a destination is being modulated by two or more sources, their effects on the destination are summed together. This means that the effect of one source used alone may be added to, subtracted from or even interfered with by the introduction of another source. This situation may be further enhanced (or aggravated) when positive amounts are used on some of the sources and negative amounts are used on the others. Keep experimenting!
- The range of a modulation may not be enough to do the job in some cases. No problem. Since mod sources assigned to the same destination are summed, just add the same Source again in another Mod path and adjust **LEVEL** until the required range is achieved. If you still need more just do it again. Also, since the same Source can be used several times, each **LEVEL** can be used for "fine tuning": a Source can be used to provide very fine increments of change if necessary. Try it.
- When modulating a destination that already has a high initial value (above 50 or so) by a positive source value, it is recommended that the initial value be set to a lower amount. This is suggested so that the modulation has enough "headroom" to be effective.
If, for example, the destination's initial setting is near its maximum, in many cases the effect of positive modulation may not be heard because the destination's amount is already near maximum to begin with. Envelope 3 Level is a good example of this—if the VCA is already wide open, adding positive modulation from another source will have no effect. Some experimentation is required depending greatly on the nature of the Modulation Page you've created.
- Conversely, when modulating a Destination that has an initial setting of a lower (below 20 or so) value by a negative **LEVEL** value, it is recommended that this initial setting be set to a higher amount. If, for example, the Destination's initial **LEVEL** is 10, in many cases the effect of negative modulation may not be heard because the Destination's amount is already near its minimum to begin with. Again, some experimentation is required.
- As you audition new MODs you've created, you may experience some results that you didn't expect. This may be due to the fact that many of the modulations are inter-related and editing one parameter could possibly affect another indirectly.

Infinite feedback loops: It is possible to program sources and destinations that result in infinite loops. For example, the frequency of LFO 1 can be modulated by LFO 1 itself. Sometimes this is useful, other times you may need to turn the MOD off to get the program to work correctly.

THE CONTROL ROUTES SECTION

As we said earlier in this chapter, modulators can be constant at the level set on the Mod page, or they can be controlled from still more modulation sources. This “modulating the modulator” control panel is called the Control Routes display. The CRoutes are Mod Route scaling control assignments. Think of them as a sort of “behind the scenes” modulation route. For example, if you’ve ever wondered why the MW appears to be hardwired to control LFO 1 modulation for both Osc 1 and 2 when you enable their respective Mod 1’s, the CRoutes are the reason why. And the CRoutes are what you would use to undo that, as well.

You reach the Control Routes display by pressing the **MOD ASSIGN, PITCH WHEEL** or **RIBBON** buttons twice. The first press of the button shows you the variables of the controller itself, but a second displays the Control Routes section, or **CROUTES** for short. There are two pages in the Control Routes display: **CROUTE** and **GRID**.

Unlike the custom modulators, in the CRoutes display a Mod Route can be assigned only one controller at any time (in the CRoutes screen, mod sources are assigned to Mod Routes). Also, only 35 of the Mod Routes can be controlled from here.

TO CHANGE MODULATION AMOUNTS USING THE CROUTES PAGE:

The easiest way to understand this section is to use it to change the most common modulation route in a program.

1. Call up a program for which the Mod Wheel brings in vibrato.
2. Double-press the Mod Assign button. This will take you to the Control Routes section and call up the Grid page showing a list of the mods that are being controlled by the Mod Wheel.

Note that the Mod Wheel is highlighted in the box to the left of the LCD. That means the destinations listed in the Grid to the right belong to the Mod Wheel.

3. Turn soft knob **1** (**SOURCE**) and watch the list in the box on the left. If it looks suspiciously like the Source list for every other modulation path on the A6, you’re right! That’s because it is the same list. Any modulation source can be used as a source for a Control Route.
*As you change sources, you’ll see what destinations they control, if any. Any destinations that aren’t controlled by a modulator will be displayed when the source is set to **OFFSET**.*
4. Double-press the Mod Assign button again to return to the Mod Wheel’s Grid page. Notice the list in the Grid on the right. Depending on the program, it probably has Osc 1 Mod 1 and Osc 2 Mod 1 listed in the farthest column on the right. The next column over to the left has the words **ON** or **OFF**, and the leftmost column shows numbers. These numbers show the amount of control the Mod Wheel currently exerts over the Mod 1 paths of each oscillator.
5. Move the Mod Wheel up and down while playing a note. You should hear vibrato on the note. Now turn soft knob **4**, which is directly under the word **ENABLE** in the display. You should see the word **ON** change to **OFF** in the first row of the Grid.
6. Carefully turn soft knob **6**, the one under the word **SCROLL**, until you have selected the next row of the Grid and highlighted the words Osc 2 Mod 1. Now turn soft knob **4** again until you see the word **ON** change to **OFF** in the second row of the Grid.

If you've done this, try the Mod Wheel again. You'll notice that it didn't bring in the vibrato this time. But notice that the LEDs for each Oscillator's Mod 1 are still on. This means the mod route itself is still active; it's just that the Mod Wheel is no longer available to increase the level of the mod.

Note that Control Sources only affect mod routes which are linked to hardware destinations such as Oscillators, Pulse Width, Filters, Pre Filter Mix, Post Filter Mix, FX sends, and the Voice Mix Pan mod. They do not control software-generated destinations like Envelope stages or LFOs.

To change the source of a control route:

The next thing to do might be to assign some other Control Source (like Aftertouch) to control vibrato via Osc 1 Mod 1 and Osc 2 Mod 1. Or we could add some other mods to be controlled by the Mod Wheel.

1. Press the **MOD ASSIGN** button next to the Mod Wheel twice.
2. Press soft button **1** (CROUTE).
You'll now see a list of SOURCES on the left, going through a LEVEL and ENABLE control, to a list of ROUTEs.
3. Turn soft knob **5** (ROUTE), (or press the up or down keys when ROUTE is highlighted), to display the destination `OSC1 MOD1`.
As you go through the list, the SOURCE being aimed at that destination will show in the display, as will its level and whether it's enabled. If the ENABLE parameter reads `HARD` instead of `ON` or `OFF`, that particular pathway is hard-wired and cannot be disabled.
4. Turn soft knob **1** (SOURCE) to select the source you want (for example, `KEY AFTERTOUCH`).
Note that the Mod Wheel no longer controls OSC1's vibrato; aftertouch will. Since there can be only one Control Route per destination, aftertouch has replaced the mod wheel.

Sometimes when programming, you may hear a modulation you want to eliminate, but you're not sure of the source. The CROUTE page offers you a way to find out what's going where and eliminate or change the level of these modulators. Simply go through steps 1-3 above to display the route you think you want to eliminate or edit.

ABOUT SIGNAL FLOW IN A MOD PATH

When you're programming a modulation, keep in mind that there are many possible level controls between the mod source and its destination. As in a mixing console, there are many places in the MOD signal path where the signal may be turned up, turned down, or switched off. In the Andromeda, this flexibility allows you to do things that are difficult or impossible on other synths.

There is no "right" way to control the levels; they simply have different consequences depending on what you want to achieve.

Below is a sample drawing/flow chart of the controls typical in the path from LFO 1 to Osc 1. At any one of these points, the amount of modulation can be affected.

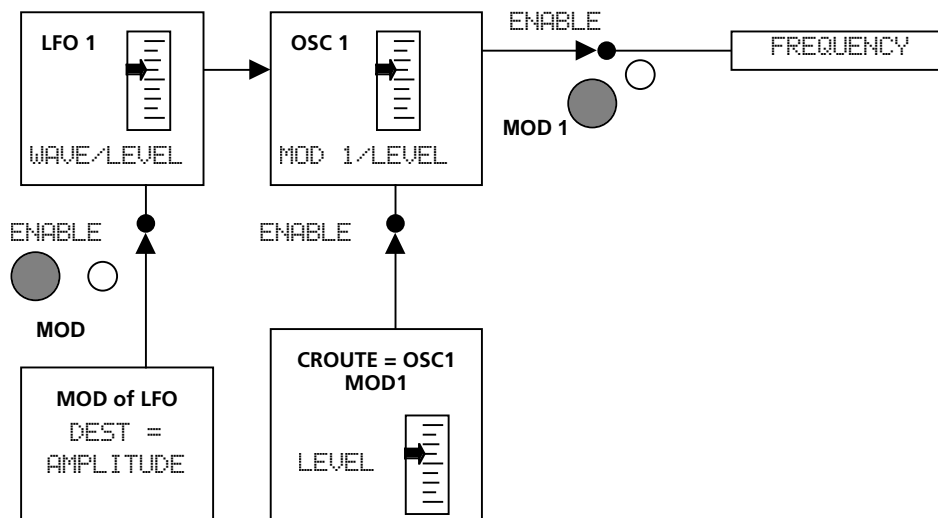

The top part of this diagram represents the basic modulation path: LFO through **MOD 1** of Oscillator 1, aimed at its frequency. To get a basic, constant vibrato, the level of the LFO module itself must be up, LFO 1 must be the source of **MOD 1**, the level of **MOD 1** must be up, **MOD 1** must be enabled, and Frequency must be the mod's destination.

The lower blocks of the diagram show the "modulators of the modulators": LFO 1 has its own **MOD** button, which may be set to control the amplitude of the LFO itself from any of the 79 Modulation Sources. If this is enabled (the LED next to the button is on), the output of LFO 1 (to all destinations, not just Oscillator 1) will be affected. Another potential level control comes from the Control Route section, which affects how much of Mod 1 will be sent on to the frequency of the oscillator. In many programs, the source of this route is the Mod Wheel; other programs may not enable this route at all.

So why have two different ways of doing the same thing? What's the difference between controlling the level of the source and controlling the level at the destination? The difference is that the diagram above doesn't show the many other possible modules that may be using LFO 1 for some purpose. It's perfectly OK to use LFO 1's **MOD** button to raise and lower the output level, but if you do, keep in mind that every other **MOD** in the Andromeda that may be using LFO 1 for some purpose will be affected at the same time.

ABOUT MODULATION SOURCES

The Mod Sources list in Appendix B near the end of the manual carries a description of each source, although they're fairly self-explanatory. But there are three categories that you should consider:

- Sources with a **VOX** prefix are per Voice, and are per-note functions.
- Sources with a **PGM** prefix, later in the list, are per Program, or are 'global' and will affect all voices at once in the same way.
- At the end of the list are Clock and Gate Sources. The clocks should be self-explanatory in name; they can be used to fire or reset modules which accommodate such (Envelopes, Seq/Arp, S/H, LFOs, etc.) The Envelope stage names at the end of the list are Gates that go high when the indicated stage is reached during the associated Envelope's cycle. You can start the Sequencer when Envelope 2 reaches Release 2, for example, or start the S/H running upon reaching the Sustain of Env 3. The End stage is provided to allow cascading Envelopes or to fire modules when an Envelope reaches zero at the end of its cycle.

Obviously, certain modulation sources are more appropriate for some destinations than others. In most cases, you won't assign a gate source to control the frequency of the oscillator. But you may get some interesting results by going beyond the standard concepts.

CHAPTER 10:

USING EFFECTS

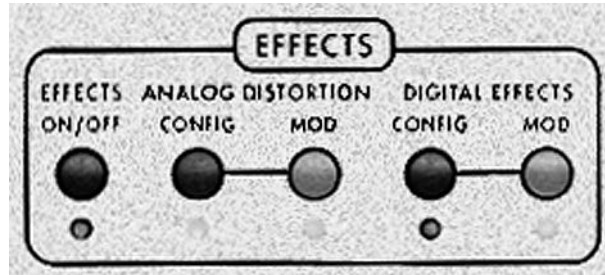

INTRODUCTION

The A6 features two complete systems of effects: one that produces a variety of **analog-generated** distortions (overdrive, classic fuzz box and more) and the other for producing an array of studio-quality **digital** effects (reverbs, delays, chorus, flanging, pitch-shifting and rotating speaker). This entire arsenal is fully programmable for each Program and Mix.

The digital effects contain a number of single effects plus some very useful multi-effects where two or more single effect generators are linked. In addition, the output of the analog system can be input to the digital effects for further processing, or fed directly to the **VOICE MIX** (in parallel to the digital effects) for a “dry” distorted output.

SIGNAL FLOW

In the Andromeda, the effects processors receive signal from the **VOICE MIX LEVEL** control (on the far right hand side of the unit). This is after the post-filter mix and the VCA controlled by **ENV 3**. The Digital Effects section can also receive signal from the Analog Distortion section if desired. The effects processors send their output directly to the **MAIN OUT** jacks only—not to the **AUX OUTS** or the individual **VOICE OUTS**.

Think of the effects section as a dedicated signal processor attached in stereo to the main stereo outputs, whose effects program changes every time you select another Program or Mix. You set the balance between the “wet” (effected) and “dry” (uneffected) sounds using the output levels of the effects pages in the display—unlike most other controls in the A6 there are no dedicated top-panel controls for effects besides the buttons shown above.

BASIC CONTROLS

The **EFFECTS** area above the display is a simple set of five buttons. The LED below each button informs you of that function’s current status. When selecting Programs or Mixes, if an LED in this section is lighted, you know that the current Program has that function enabled. By the same token, if any one of these LEDs is off, you know that its associated function is not part of the current program.

EFFECTS ON/OFF – Both the Analog Distortion and the Digital Effects systems are turned on or off by pressing this button. Although fully programmable for each

Program and each Mix, any and all distortions/effects stored with a Program or Mix can be disabled with this button. The on/off status is programmable.

CONFIG – There are two Configuration buttons, one for the Analog Distortion system and one for the Digital Effects system. A *configuration* is an arrangement of one or more effects. Each Analog Distortion and each Digital Effect in the A6 use one configuration at a time. Pressing either **CONFIG** button enters either Analog Distortion Edit or Digital Effects Edit mode and displays the current Distortion or Effects settings for the selected Program or Mix.

MOD – Like many other functions in the A6, several parameters in the Distortion and Effects systems may be modulated by envelopes, LFO's and many other sources. Pressing either **MOD** button enters Modulation Edit mode for that system. The A6 displays the available mod destinations and allows the user to select any of the 79 modulation sources.

ANALOG DISTORTION

Analog Distortion has one simple configuration, with four different types of distortion available: **EASY**, **LIGHT**, **HEAVY**, and **KILLER**. It has three outputs, any or all of which can be switched on or off: **MAIN**, **DFX1** and **DFX2**. The latter are two separate inputs to the digital effects section, which are useful in multieffect (stereo-input) configurations only. For example, you can have the left side of a chorus distorted, while the right side is clean.

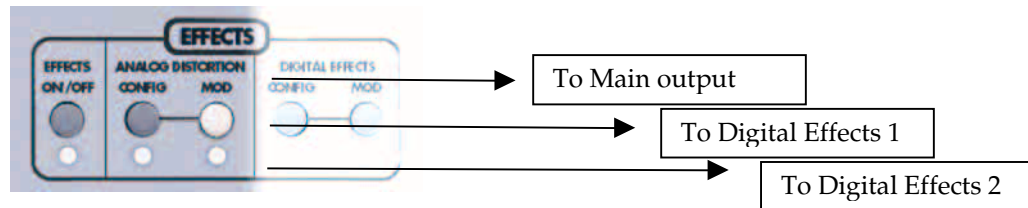

There's only one page when you press Analog Distortion's **CONFIG** button: the **ANAFX** page which allows you to set the **SEND** (input) level, select the **TYPE** of effect, the **OUTPUT** level, and turn the three outputs on and off.

Digital Effects

The **CONFIG** page

Soft button 1 is always the **CONFIG** page, which is the "home page" of the digital effect in use. Here's where you set the input and output levels, and if it's a multieffect of any kind, the mix between them. But most importantly, this page lets you select the Digital Effects Type. There are 28 different configuration types available, each of which fall into one of four categories: Single, Dual Stereo, Dual Mono and Multi Chain.

The Configuration page displays a graphic of the effect block or blocks being used. If a multi-effect is used, the display will also show you the **order** of the multi-effects that the audio will pass through and whether this is a Stereo or Dual configuration (more about specific configurations later in this Chapter).

Parameter pages

Soft buttons 2 through 6 are reserved for selecting the current configuration's Edit Pages: each configuration can have up to five pages of editable parameters. Here's where you make the effects sound different—long or short decays, fast or slow speed, etc. The parameter pages are labeled differently depending on the type of effect.

MOD page

Soft button **8** brings you to the **MOD** page. As with any of the other modulation options on the A6, you can use any of the 79 modulation sources to increase or decrease the level of the destinations, which are the inputs to the digital effects:

```
DFX SEND LEFT
DFX SEND RIGHT
DFX SEND L&R
DFX PAN
```

Note that modulating these will have no effect if that parameter doesn't exist in the particular configuration. For example, there is no PAN in the Large Hall configuration. Single Configurations are fed by a mix of the Left and Right digital effects busses, so their input level may be controlled by modulating DFX SEND L&R; there will be little effect if you modulate only the Left or Right send.

Note that if you've edited an effect, changing to a new Program or Mix without first pressing the **STORE** button will result in the loss of changes. If you want to hear what the effect sounded like before your changes, the **COMPARE** button will work for Distortions and Effects as well.

EDITING DIGITAL EFFECTS

A Configuration is made up of one or more effects. Each of the Programs and Mixes of the Andromeda contains its own Digital Effects Configuration. When you want to create your own effect from scratch, the first thing you must decide is which Configuration Type you wish to use.

TO SELECT A DIGITAL EFFECTS CONFIGURATION TYPE:

1. Enter Digital Effects Edit mode by pressing the **DIGITAL EFFECTS CONFIG** button on the top panel. The **CONFIG** page will be displayed.
2. Turn soft knob **8** to select one of the 28 types with the **TYPE** parameter.
The abbreviated name of the effects will show in the display above the knob; when you stop on one for a moment, the entire configuration will be displayed with its full name.

After you've adjusted the send and output levels of the effect, you can then change the parameters of each effect block, just as you can on any external effect processor. That's all there is to it. Now you can start editing the effect's parameters, and having some real fun!

For information on the individual configurations, see page 211.

Remember: If you decide you want to select a different Program, you can always do so by pressing one of the Program keys. However, if you select another Program after making changes and without storing the Program back into memory, the changes you have made will be lost.

EDITING EFFECT PARAMETERS

CHOOSING A PARAMETER PAGE

To select an effects edit page, press a soft button under the page “tab” on the bottom row of the display. In single effects, these pages are named PARAM1, PARAM2, etc. In a multieffect each parameter page is named after the effect “block” it controls: PLATE1 PLATE2 etc. The total number of Parameter pages depends on which Effect Type the Program uses. The currently-selected page tab will have a box around it like this:

PARAM1

Once you’ve entered a parameter page, the display shows up to six parameters at once. Each parameter is displayed as a bar graph of its current value, relative to its minimum and maximum values. The current value of a parameter is shown numerically just under the bar graph. If the parameter is turned off, OFF will display in that section instead. Below the Parameter Value Row is the Parameter Name Row, with the abbreviated names of the parameter (which are explained individually later in this chapter). The complete name of the currently-selected parameter is shown on the right side of the display, under the effect type.

CHANGING AN INDIVIDUAL PARAMETER

Selection of a parameter (such as DECAY, BOOST or LPF on the middle row of the display) happens automatically when you touch the soft knob for that parameter. As you adjust a parameter, both its numerical value and bargraph will change in relation to the slider’s position.

Tip: To make a small change to a parameter, you can repeatedly press the page’s soft button, and each parameter on the page will be selected in turn. Its name will be displayed in reverse type like this:

DECAY

Then, you can use the ▲ or ▼ buttons to change the value by small amounts.

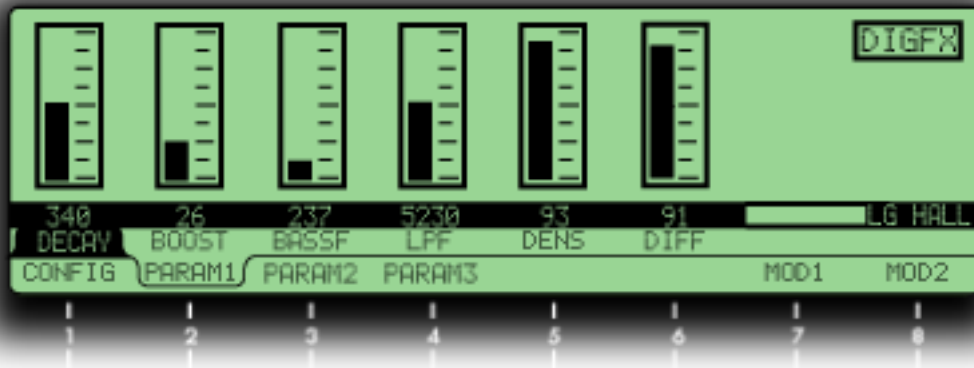

MOD: MODULATING EFFECTS SEND/OUTPUT

Pressing an effect's **MOD** button on the top panel, or pressing soft button **8 (MOD)** while on any Effects Edit page displays a Modulation page for the Analog Distortion or Digital Effects systems. Here you are able to select up to two sources that can be used to modulate output levels of the Analog Distortion or Digital Effects sections.

The Modulation page will display the modulation destination(s) and its sources, along with **LEVEL**, **OFFSET** and **ENABLE** controls. Pressing the **MOD** key on the top panel of the Analog Distortion or Digital Effects section has the same effect as turning **ENABLE** on and off on the display. Turn soft knob **1** to set the **SOURCE** for the mod from among the 79 possible choices.

When a mod source is selected, its effect on the destination is heard instantly while scrolling through the list. Any changes made will remain active so long as you do not switch Programs or Mixes. They will only be saved when you press the **STORE** button and save the entire Program or Mix.

TUTORIAL: HOW TO EDIT A REVERB

The best way to learn a new piece of gear is to start using it in your studio. This section is designed to teach you how to edit your own effects using normal day-to-day examples. Remember that programs are subjective and these are just guidelines. If the program sounds weird when you're all done, change it - that's what the soft knobs are for!

You can use the following section to edit any Program or Mix in the Andromeda. But to get started, use a basic bass or pad patch that doesn't have many effects to begin with. Whatever its effect type is, we're going to change it to a simple reverb. This will be a typical large, warm hall program, with a lot of space to swim around.

SET THE TYPE AND AUDIO LEVELS

1. If it's not on already, press the **EFFECTS ON/OFF** switch to turn the LED on.
2. Enter Digital Effects Edit mode by pressing the **DIGITAL EFFECTS CONFIG** button on the top panel. The **CONFIG** page will be displayed.
3. Turn soft knob **8** (the **TYPE** parameter) fully counter-clockwise to select **LG HALL** (Large Hall).
4. Increase the **SEND** level to about **80** using soft knob **1**, and the **OUT** level to **80** using soft knob **7**.
At this point, you will probably be able to hear reverb when you play the keyboard.
5. Press soft button **2** (**FARAM1**).
You'll now see six different parameters in the display.

SET THE REVERB'S DECAY AND TONE

The quickest way to change the sound of any reverb program is to change the Decay and LPF (Low Pass Filter) parameters. The Decay time (soft knob **1** on this page) dictates the size of the room, and the LPF (soft knob **4**) emulates the wall surfaces. To simulate a large castle chamber with a few tapestries and other soft surfaces, we'll set the decay fairly long and the LPF relatively low. Don't worry if the decay time seems long, we can do other things to trim it down later.

6. Set the **DECAY** to around 4.638 (seconds) using soft knob **1**.
7. Set the **LPF** to 5.650 (kHz) using soft knob **4**.

Our next step is editing the Density (**DENS**) and Diffusion (**DIFF**) parameters. These are less obvious to hear, but can make a big difference on your sound. Density (soft knob **5**) affects how smooth the attack will be, and can approximate different surface textures. A very high density would be good for simulating a polished marble room, for example, and lower densities would simulate a rougher surface with more discrete echoes. A Program with a very fast Attack and Decay can be a big help when programming Density and Diffusion; it's much easier to hear than on a sustained sound—but don't change Programs now or you'll lose your changes so far! Play the keyboard while moving the Density up and down with soft knob **5** to hear its effect on the hall.

8. Set the Density (**DENS**) to 74% for this room - not too rough, but not too glassy either.

The Diffusion parameter (soft knob 6) sets how smooth the decay will be. Used in conjunction with the Density parameter, it can be used to approximate hundreds of room textures. Again, use the keyboard to check if the room is getting too ripply or too glassy.

- Set the Diffusion (DIFF) to 78%.

SET THE REVERB PREDELAY

Our next step is editing the Pre-delay parameters on PARAM2. (We'll come back to the Bass Boost parameters once the program is structured better.)

- Press soft button 3 (PARAM2)

Pre-delay was originally used to simulate the delay before hearing reverberation in a large hall. However, in modern reverb program it is used more for effect. You can use pre-delay on a bass sound to make the initial attack clearer. You can also leak some non-predelayed reverb using the Pre-delay Mix (PDMIX) if you want. For this program, let's try a Pre-delay Time (PDTIME) of 32ms with 100% mix for a splash of reverb.

- Turn soft knob 1 until the value of PDTIME is 32.
- Turn soft knob 2 (PDMIX) all the way up (100).

CHANGE THE TONE OF THE REVERB DECAY

The Low and High Frequency Damping parameters are controlled by soft knobs 4 and 5 on this page (LDAMP and HDAMP). The damping parameters interact with the Decay time according to frequency. In a hall with no high frequency damping, the high frequencies will "sizzle" with a long decay. With no low frequency damping, the low frequencies will boom with a long decay, as in a large cement parking garage. Raising the frequency of the Low damping will cut the decays below that frequency (like adding bass traps to the hall), and lowering the frequency of the High Damping will cut the decays above the frequency (like adding drapes and couches to the hall).

For this room, leave Low Damping off and set High Damping for 2.14kHz as follows:

- Turn soft knob 4 all the way off (LDAMP = OFF).
- Turn soft knob 5 to set the High Frequency Damping (HDAMP = 2.140).

Remember that if you set the High Damping higher than the input LPF, it will do almost nothing. Notice how the apparent decay drops off when you do this, and that the room starts to sound more natural.

Press soft button 4 (PARAM3) to see the last parameters of the Large Hall Reverb program. Swirl (soft knob 1 of this page) is an effect which simulates moving walls. Set to a low value, it can add subtle movement to your reverb sound. Set high, it adds chorusing to the room. We'll leave it off in this example. We're not looking for a gated reverb sound, so we'll leave Gate set to zero (otherwise, it will "chop off" the reverb sound once it reaches a certain point).

```

  0    60%    0    0    0
SWIRL DEPTH  GATE  HOLD  RELEAS

```

Now we're ready to go back to the `PARAM1` page, parameters 2 and 3. Bass Boost can be useful for adding a little warmth to a hall program. By setting the frequency to 237Hz and the Level to 100, we can add a touch of warmth to our hall program.

15. Press soft button **2** (`PARAM1`) to return to that page.

16. Using the soft knobs, set `BOOST` to 100 and `BASSF` to 0.237.

ADJUST THE MIX

Now, you can go back to the `CONFIG` page and adjust the `SEND` and `OUTPUT` levels for whatever balance of "wet and dry" you want.

Setting Input Levels

For quietest operation, it's best in most cases to leave the input level high, and if you want less reverb, to turn the output level down. The input level should be high enough to be well above the noise floor to get the best dynamic range, but not so high that it clips the digital effects engine itself. If you see the word **CLIP** appear in the lower right side of an effects page, lower the `SEND` level on the `CONFIG` page.

Setting Output Levels

On the other hand, it is possible to set the Output so high that it can clip the final summing amps of the Andromeda. If this happens, you'll hear it. Turn off the **EFFECTS ON/OFF** switch to make sure it's the effect, and not something in the program. If it's the effect, restructure your gain. Sometimes this means going all the way back to the levels of the `PRE FILTER MIX`.

To "SOLO" the Effects

To hear the reverb and only the reverb while you're listening to the Main Outputs, simply press the **OUTPUT** switch on the far right of the top panel to remove the program audio from the Main Output. The effects will still be feeding the output, without any "dry" signal mixed in.

DIGITAL EFFECTS ARCHITECTURE



This section describes the 28 configuration categories for the Digital Effects system.

THE SIGNAL FLOW THROUGH THE EFFECTS SECTION

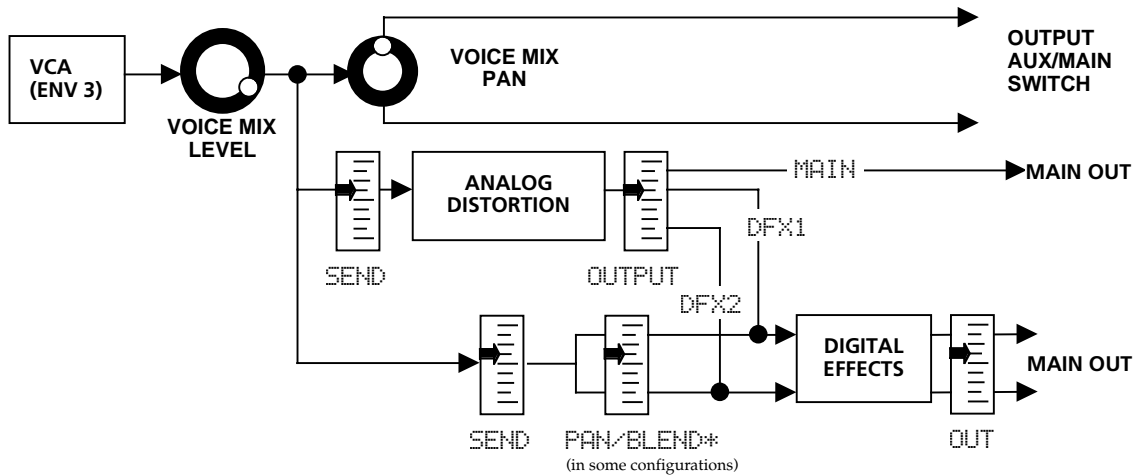

As you can see in the flow chart above, the effects section gets its input from the Voice Mix Level pot. At this point, the signal is mono. This signal appears at the SEND controls of both effects units. The Digital Effects unit can receive signal from its own SEND control, but even if this is all the way down, it can still receive signal from the Analog Distortion section's output. Now that you understand where the input to the Digital Effects comes from, let's look at what goes on inside the Digital Effects system:

SINGLE

A Single configuration consists of one effect. These configurations utilize complex, processor-intensive effect algorithms providing the best quality possible for each effect type supported.

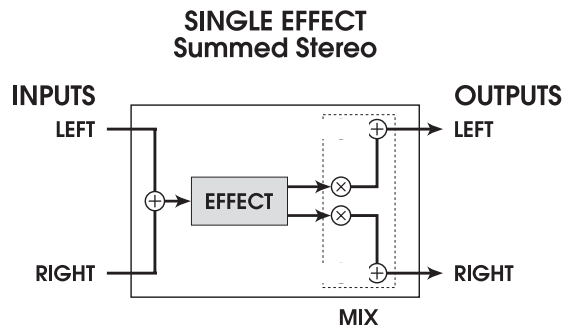

Effects that use this configuration:

- | | | |
|-----------------|--------------|------------------|
| Large Hall | Chamber | Large Plate |
| Hall Reverb | Ambience | Mono Delay |
| Room Reverb | Plate Reverb | Nonlinear Reverb |
| Ping Pong Delay | | |

STEREO

The Stereo Room, Quad Pitch Shifter and Quad Chorus configurations are special single algorithms that treat the incoming left and right signals differently, but still create a synthesized stereo image from each side, depending on the setting of the Width control. If the width is set to 99%, a signal appearing at the left input (as set by the PAN control inside the effect display—NOT the control on the Voice Mix output section) will be processed and sent to only the left output; if the width is set to 00%, the processed signal will appear in stereo at both outputs. Stereo Chorus/Flanger has two separate mono signal paths that are controlled by **synchronized parameters** to give a total stereo effect.

Stereo Chorus/Flanger is not always a Stereo Effect, because each side of the chorus feeds only one side of the output. Depending on its input PAN setting, it can assign the chorus to either or both channels. Unlike the Dual Mono configurations, however, it doesn't have independent control of the parameters for each side, or left and right output level controls.

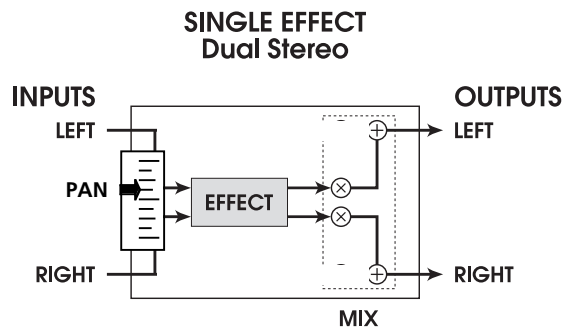

Effects that use this configuration:

- Stereo Room
- Quad Chorus
- Quad Pitch Shifter
- Stereo Chorus/Flanger

DUAL EFFECTS: PARALLEL

Parallel configurations consist of two discrete “side-by-side” **mono-in/stereo-out** effects. These configurations are identified by the presence of a “+” in their name, and by a **BLEND** control between the input and the effect. In each case, the left output of the Blend control is routed to one effect, while the right output is routed to the other. The stereo outputs of both effects are then summed together to the outputs.

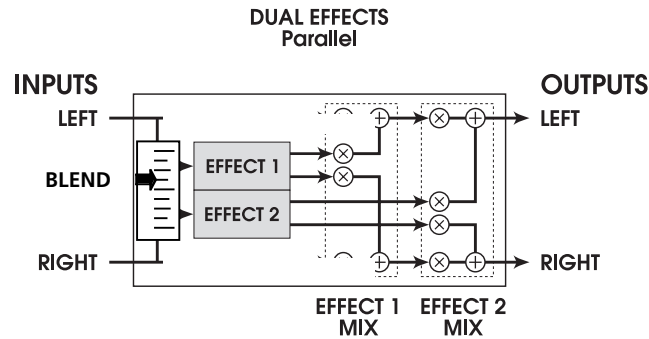

Effects that use this configuration:

| | |
|-------------|-------------|
| Room+Hall | Room+Plate |
| Plate+Hall | Room+Delay |
| Room+Chorus | Room+Flange |

DUAL EFFECTS: MONO

Dual Mono configurations consist of two discrete “side-by-side” **mono-in/mono-out** effects. These configurations are identified by the presence of a “:” in their name, and by separate left and right output controls, one for each effect. In each case, a **PAN** control allows you to set how much of each effect you want on each side. Left input is routed to one effect, while the right input is routed to the other. Unlike the parallel effects, in these mono effects the left signal only feeds the left output, and the right signal only feeds the right output. **Chorus:Chorus** and **Delay:Delay** have **independent control of the two effects**.

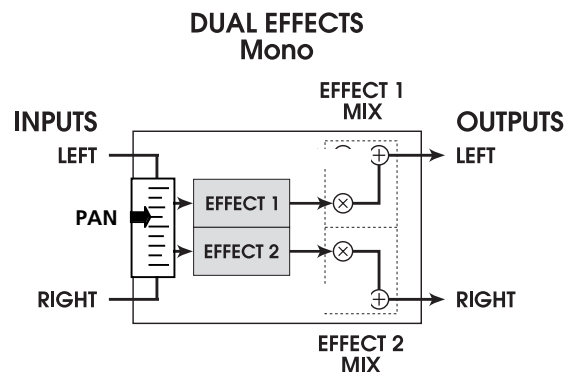

Effects that use this configuration:

| |
|---------------|
| Chorus:Chorus |
| Delay:Delay |

MULTI CHAIN

The Multi Chain configurations provide two or three stereo effects, which are connected in series: one feeding the next in the chain. These configurations are identified by a ">" symbol in their name, for example CHRS > RM (Chorus->Room).

These individual effect types provide excellent sound quality but are less processor-intensive than their Single configuration equivalents, since the Digital Signal Processor is accommodating more than one effect at a time. In other words, the reverb effect in the "Delay → Room" configuration is not as "dense" as the Single configuration called "Room Reverb".

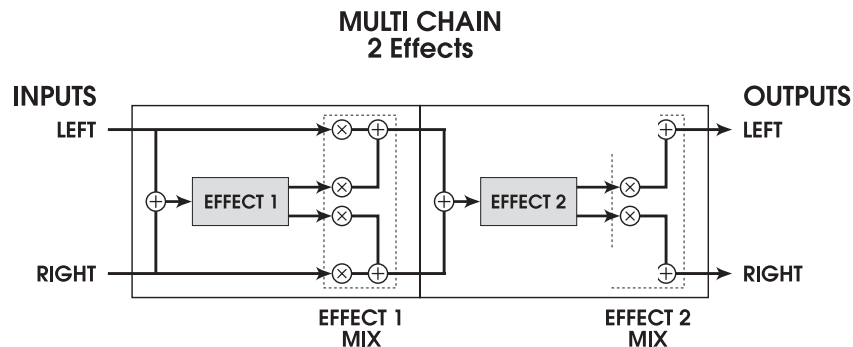

Effects that use this configuration:

| | | |
|---------------|---------------|--------------|
| Lezlie → Room | Delay → Room | Room → Delay |
| Chorus → Room | Room → Flange | |

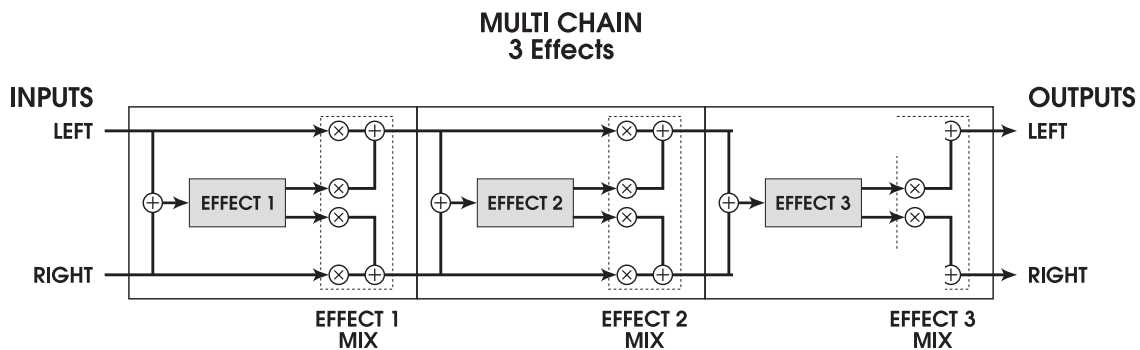

Effects that use this configuration:

MULTI 3 (Flange>Delay>Room)

In the case of Multi Chain configurations, the MIX parameter of each effect determines what the following effect receives at its input(s). For example, it is possible to use the "Delay → Room" configuration (where Effect 1 is a mono delay and Effect 2 is a reverb), and have only the dry, undelayed signal going to the reverb. This is done by setting the first effect's MIX parameter to 0.00. This means that the previous effect chain is bypassed and all the signal is coming directly from the effects SEND control. A setting of 100.00 (full up) means that the input comes entirely from the previous effect block—in this case, that the entire signal to the reverb is delayed.

CONFIGURATIONS & PARAMETER DESCRIPTIONS

This section provides detailed descriptions of the available Digital Effects and their related parameters. A comprehensive Table of Parameters is provided at the end of this section.

REVERBS

Reverb Configurations

Reverb is made up of a large number of distinct echoes, called reflections. In a natural acoustic space, each reflection's amplitude and brightness decays over time. This decaying action is influenced by the room size, the location of the sound source in the room, the hardness of the walls, and other factors. The A6's Digital Effects system offers the following types of reverberation:

Large Hall

This is a simulation of a large concert hall. Halls tend to be large rooms with lots of reflective surfaces, where sounds can swim around, changing timbre over time. This is a classic reverb which sounds good on just about anything.

Hall Reverb

This algorithm is similar to the one above, but the sound is not as "thick" and there are programmable early reflections. You might use this configuration instead of the Large Hall to get different hall characters or shapes. This configuration also has twice the predelay time of the Large Hall, 500ms instead of 250ms.

Room Reverb

Room Reverb gives you the sound of a medium-size studio room. It has a quick attack and programmable reflections. It's a good, tight, instrumental sound.

Chamber

Similar to the Room Reverb, this algorithm simulates a polished live reverb chamber. It differs from the Room in character; the chamber is smoother and more transparent. It sounds great on many programs, especially if you're looking for a non-obtrusive sound.

Ambience

This algorithm simulates a very small room. It can be used when just a slight amount of ambient character is needed to augment a sound. This works great for percussive programs or anywhere you want to add space without a lot of long reverb.

Stereo Room

This algorithm is a true stereo room for use with stereo sources. The width is programmable and simulates the space between two microphones in a large room. The higher the width value gets, the closer the room gets to being two mono rooms with no bleed to each other.

Large Plate

This is a simulation of a classic echo plate, a 4' by 8' suspended sheet of metal with transducers at either end used to produce reverb. Popular in the 1970's, it still prized for its transparent sound. This algorithm uses the most processing available for a truly realistic reverb plate simulation. It works well for a lush, classic rock and roll sound.

Plate

Plate is a variation on Large Plate. This version is not as "thick" and can sound better on shorter, more percussive patches.

Nonlinear

This reverb effect's direction can be set either forwards or backwards. Selecting the forward direction provides a classic "Gated" digital reverb sound. Selecting the reverse direction gives you a backwards reverb sound. A popular trick in the 80's was to record the reverb with the tape flipped over, so it would play backwards in the mix. The reverse reverb is a useful effect for percussive sounds -adding space without washing out the instrument.

Reverb Parameters

Most of the reverb effects in the A6 operate under the same set of control parameters, which are listed and described in this section. However, reverbs which use more processing power (i.e. the Single configuration reverbs) provide more parameters which take advantage of their extra processing power; parameters which are not found in the other, smaller reverb algorithms. For example, Reverberation Swirl is a parameter found only in the Single configuration reverb types. Here is a list of all reverb parameters found in the Digital Effects system:

Decay

The Reverb Decay determines how long the Reverb will sound before it dies away. When using the Reverse Reverb effect type, the Reverb Decay parameter controls the Reverse Time. This parameter dictates the size of the space you are emulating: small rooms have a short decay (500ms-2 Sec) while large halls have a long decay (2-6 Sec).

Low Pass Filter (LPF)

The lowpass filter can be set between 029 Hz and 41.3 kHz, and attenuates all frequencies above this value by 6dB per octave. The lower the setting, the less high frequencies are allowed to pass thru to the reverb effect.

The LPF simulates the reflectivity of the space you're emulating. A tiled room may roll off around 12kHz, where a living room or a warm church might roll off at 6kHz. An instrument may also dictate how "bright" the reverb should be. If you want to add sustain to a program without cluttering up the mix with reverb from the initial filter attack and initial transients, set the LPF around 2 or 4kHz.

High Pass Filter/Low Shelf (LSHELF/HPF--Plates only)

Classic plate reverbs often have a midrangy twang to them. Since this frequency bump is part of the character of a plate reverb, the A6 allows you to roll off the highs (see above) and low frequencies on Plate reverbs. The High Pass Filter (HPF) parameter controls the frequency where the low end will begin to roll off (at a rate of 6dB per octave). The Low Shelf controls how deep the cut will be - from barely noticeable (high value) to completely cut (low value).

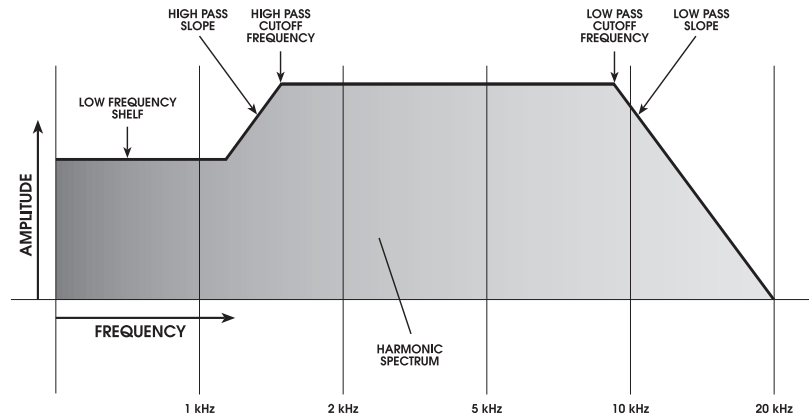

Bass Boost (Halls only)

The Hall reverb type allows you to add bass to the input signal before processing. This can make the halls sound “warmer”, or even add rumble at extreme settings. The **BASSF** parameter selects the highest frequency which will be boosted, and the **BOOST** parameter sets the amount of boost, up to 6 dB.

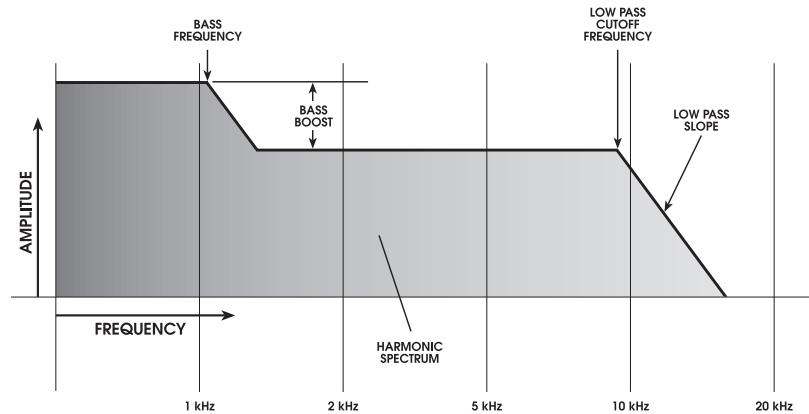

Pre-delay (PDTIME)

All the reverb effects have pre-delay parameters. Pre-delay slightly delays the reverb itself up to 500 ms, so that the dry signal more easily stands out from the reverb. A bit of pre-delay can make certain instruments sound bigger. It is also useful when simulating big spaces, where the echoes may take a moment to build up. You can also use pre-delay in conjunction with early reflections to dictate various room shapes.

Pre-delay Mix (PDMIX)

This allows you to balance the amount of Pre-delay to Direct Signal as a percentage of each. This gives you the ability to hear a bit of the Reverb before the Pre-Delayed Reverb sounds, making the delay less apparent.

Density (DENS)

Density controls how smooth the reverb decay and early reflections sound. When set for very low values, the decay is “bumpier” and simulates a large room with lots of distinct echoes. If the density is set high, the reverb will be very smooth, like a chamber or tiled room. Try using lower density settings on sustained sounds, and higher density for percussive sounds.

Diffusion (DIFF)

Diffusion determines the “thickness” of the reverb sound by adding more reflections to the reverb’s decay. With lower diffusion settings, you may be able to hear the individual echoes that make up the overall reverb sound. With higher diffusion settings, the echoes increase in number and blend together, washing out the reverb’s decay.

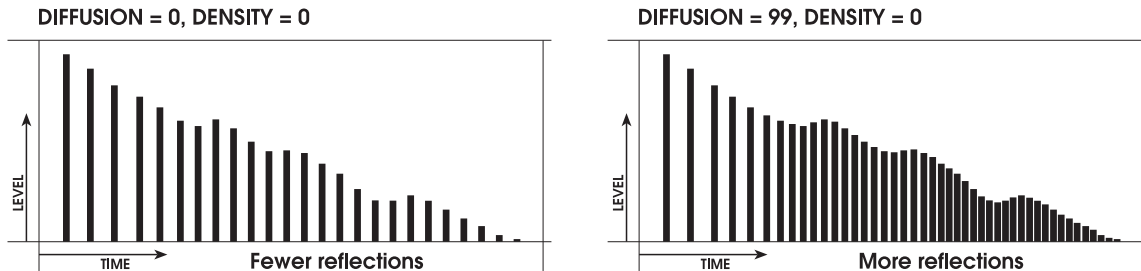

Frequency Damping - Low & High (LDAMP and HDAMP)

These two parameters allow you to control the equalization of the reverb’s decay separately for both the low and high frequencies. This means that you have control over the tonal shape of the Reverb itself over time, being able to cut the high frequencies if the effect is too bright, and being able to cut the lows if the effect is too boomy. These parameters allow you to simulate different surfaces of a room or hall, with softer surfaces absorbing high frequencies and harder rooms (parking garages, tiled rooms) diffusing low frequencies. Example: If a room has lots of hanging drapes, the high frequencies will decay faster than the lower frequencies.

Note that the Low Pass Frequency and High Damping parameters are related. If your LPF is set for 8kHz, and the High Damping parameter is set above 8kHz, you won’t hear much of a change from this parameter. This is because the high frequencies have already been rolled off, so there’s nothing left to dampen. In most cases, make sure that the LPF is set above the high damping frequency to get the most out of this effect. However, since reverb is a random function, some high frequencies can be generated over the course of a long decay which are higher than the LPF. In these cases, setting the High Damping at the same frequency or higher than the LPF will attain audible results. In either case, by using the LPF and High Damping in conjunction, you can yield a more authentic room sound.

ER: Early Reflections - SPREAD, SHAPE and ELEVEL

The Early Reflections of a reverb add attack to the room and dictate the room’s size.

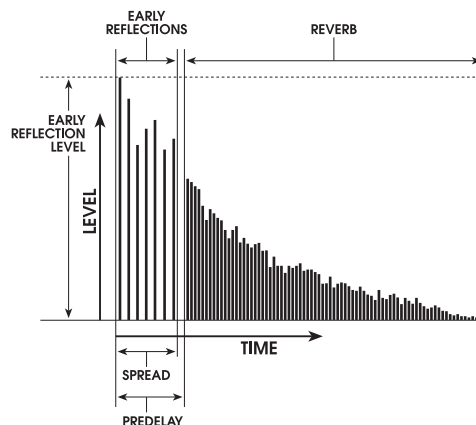

The Shape parameter controls how the reflections fade out over time. Different shapes will dictate the shape of the room and the intensity of the attack. The Early Reflection shapes are diagramed below:

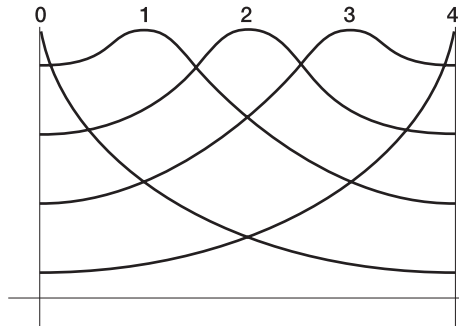

These shapes range from 0, which fades immediately and is good for small rooms, to 2, which builds and then falls to approximate a hall, to 4, which builds up slowly for a long “bloom” reverb. These shapes can then be scaled using the Spread parameter, explained below, to better emulate various spaces.

The ELevel parameter controls how loud the early reflections will be compared to the reverb’s “body”. The Spread parameter scales how close the reflections are to each other. If Spread is set for 500ms, the last reflection will be 500ms away from the first and the room will seem larger. Use Spread in conjunction with Shape to define the character of your reverberant spaces.

Depth

The Depth parameter makes the reverb sound wider and deeper. At 0%, the reverb sounds like it’s coming from the speakers and slightly behind. At settings of 60% and above, the reverb sounds like it’s around you and farther behind the speakers. Use a low setting for better mono or surround encoding compatibility and higher values for a huge stereo sound.

Width (Stereo Room only)

This setting simulates the distance between two microphones in a stereo room. When set to 100%, you get two mono rooms. When set to 0%, you get a mono in, stereo out room. When set anywhere between these values, a sound which starts on one side reverberates there then bleeds over to the other side.

Swirl

This parameter is very useful for adding randomness to the decay of a reverb when set to a low value. When set to a high value, it creates a more dramatic chorusing effect as the reverb decays.

TIME and DIRECTION (Nonlinear only)

Gating is the process which abruptly cuts off the reverb’s decay for a more “choppy” sound. This effect was very popular on drums in the ‘80s because it makes them sound HUGE. It is achieved by dropping the level of the signal very rapidly after the initial attack making a short, sharp sound. The Nonlinear configuration is permanently in a gated mode, with the TIME parameter in place of the more typical DECAY time; other reverbs may be gated using the GATE parameter (typically on the last parameter page).

The DIR parameter (soft knob 1 of the PARAM2 page) can be set to FORWARD or REVERSE. In Forward, it’s a classic gated sound; in Reverse, it’s reversed as if the reverb were coming from a backwards tape of the input. The Hold Time determines

how long the gate will be held open before it begins to turn off; this can be set from 100 to 600 ms.

GATE (Reverb Gate Level Damping)

This parameter creates the effect of plugging an expander/gate on the output of a reverb, giving the famous gated reverb effect. GATE essentially sets the threshold of the expander. When set to zero, there is no cutoff by the gate and the reverb decays normally; higher values of GATE will "chop off" the reverb at earlier and earlier points. The GATE parameter interacts with the following two parameters:

HOLD (Gate Hold Time)

This sets the amount of time the signal will be "held open" after the gate threshold is crossed. If the signal remains below the threshold level and the hold time is completed, the release segment will begin:

RELEAS (Gate Release Time)

When the gate closes, this sets the curve of how abruptly the effect will be closed down: almost immediately, or fading away gradually.

DELAYS

Delay Configurations

Delay provides a discrete repetition of a signal. By adding feedback within the effect, the delayed signal can repeat many times, with each successive decay softer than its predecessor. Each of the Delay types allow you to adjust their delay time in milliseconds (1/1000 of a second). The A6 offers the following types of delay:

Mono Delay

This Single configuration provides delay of signal up to 5499 ms (5 1/2 seconds). The delay time can be adjusted separately by 100ms, 10ms and 1 ms increments. Feedback is also available to increase the complexity of the signal. You also have high and low frequency cutting, which gives you the ability to equalize the effect's decay. This can help emulate an old tape-style echo where each successive echo is darker than the previous one. Also available are Density, Modulation (chorusing), Tremolo and Autopan.

Delay:Delay

This Single configuration provides two separate right and left channel delays which can be individually adjusted for delay time, feedback and high and low cutting. The delay time can be adjusted separately by 100ms, 10ms and 1 ms increments.

Ping Pong Delay

So called because the output bounces from left to right in stereo with the speed determined by the delay time. Again, low and high frequency cut is available. The delay time can be adjusted separately by 100ms, 10ms and 1 ms increments.

MultiTap Delay

This is like having five delays at once. Each of the "taps" have individual delay, level, panning and feedback controls. By adjusting the delay time of each tap, you can create sophisticated rhythms.

Delay Parameters

Some of these parameters (Feedback, etc.) are found in all of the Delay configurations, where others are found only on the single delays. Following is a list of all Delay parameters found in the A6:

Delay Time (100MS, 10MS, and 1MS)

In most cases, the delay time is separated into three parameters for fine-tuning the time: 100mS (milliseconds), 10mS, and 1mS. Maximum delay time depends on the configuration; the Mono Delay offers up to 5499mS of delay while the Ping Pong delay offers only 2499mS.

Feedback (FDBK)

The Feedback parameter controls the regeneration of the delay. If feedback is set for 0, you will only hear one delay. If it is set for 99, the delay will continue to repeat for days. The feedback can also be set for negative values (-1 to -99). Negative values produce out-of-phase delays for a thinner sound.

Low Cut/High Cut (LOCUT/HICUT)

These parameters filter the input and feedback of the delay. They can be used to make a “warmer” or “thinner” delay sound. The filters can each be set for Off or 29Hz to 41.3kHz and they roll off at 6dB per octave.

Density (DENS)

Similar to the Density parameter on the reverb programs, this adds several quick delays to the initial delay time. This effect “smears” the delayed sound, so the result is more like a small room than a discrete echo.

Rate/Depth

These parameters work like the pitch modulation parameters on the Chorus/Flange configurations (see next section). This allows you to add chorusing to a delay for a richer effect. Used in conjunction to the tremolo and autopan parameters, you can even create unique panning chorus effects. To bypass this effect, simply set the Depth to 000.

Tremolo Rate/Depth (TREM, TREMD)

This effect adds a tremolo effect to the delay return. You can use it as a simple tremolo by setting the delay time to 000mS and the Tremolo depth and Delay Mix to 100%. Or, you can use it in conjunction with the delay to produce delays which fade in and out. Rate controls the speed and Depth controls the intensity of the effect.

Pan Rate/Depth (PANR, PAND)

These parameters control an autopanner which effects the delayed signal. Like the Tremolo effect, you can set the delay time to 000mS for a simple autopan effect or use it with the delay for panning delays. Rate controls the speed and Depth controls the intensity of the effect. Make sure you have the OUT level set high enough to hear the effect of the pan or tremolo.

Tip: Note that all of the modulation effects have similar Rate scales. By setting the rates to the same values (or multiples of each other; double, quadruple, ...) you can “sync” them to each other. Use this trick to create swirling, panning choruses, flanges which fade in and out every cycle, or anything else you can come up with.

PITCH EFFECTS

Pitch Configurations

The Pitch effects alter the pitch of a signal in various ways to produce “layered” timbres that are more complex than the original signal. Although some of these effects can sound similar to one another depending on the parameter settings, each is achieved differently and can be quite dramatic under the right circumstances. Pitch effects are achieved by splitting the signal into at least two parts, affecting the pitch of one of the parts, then mixing them back together. This eventual mixing is essential since the overall sound of the effect is achieved by the actual difference between the dry, unaffected signal and the effects signal. The various types of Pitch change are:

Chorus/Flange

Chorus and Flange are combined into one configuration, since the only difference between these effects is the time range of delay the effect “scans”, so they sound slightly different. A predelay of 0-14 will produce a flanger, and a delay of 15 or more will chorus. Note that on Choruses and Flangers, the “Wet” and “Dry” signals need to be mixed in order to hear the effect—in other words, if the Program/Mix is not assigned to the **MAIN OUTPUT**, you’ll hear a vibrato instead of a chorus or flange.

The Chorus/Flange effect is achieved by splitting the signal into three parts with a dry signal and a separate Detuning section for both left and right channels, offset from one another. The detuning is further effected by being modulated by an LFO (low frequency oscillator) which causes the detuning to vary. Many variables are available in this scheme: the Predelay can be varied, the LFO depth can be varied, the LFO speed can be varied, and a portion of the detuned signal can be fed back to the input to increase the effect. Finally, the waveform shape of the LFO can be changed from a smooth sinewave, to a more abrupt triangle wave to make the pitch detuning more pronounced.

Flanging is similar to chorusing, but modulates the delayed signal over a much shorter delay range (typically 0-12 ms). This produces a “jet airplane”-like sound because of the high-frequency comb filtering that sweeps across the frequency range as the delay varies. The flange modulation sweep can be triggered by the audio input in order to sync up with the rhythm of your playing. You can adjust the attack and release threshold of this audio triggering function.

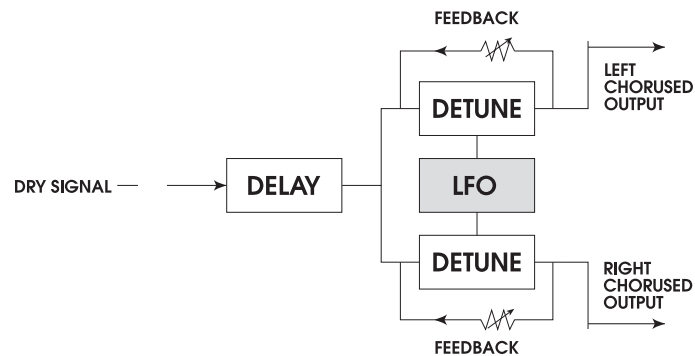

The A6 has filters on the input and the feedback loop to tailor the frequency sweep of the effect.

Quad Chorus

Quad Chorus modulates four delayed signals, each with independent rate and depth controls. Each of the four signals has a separate Predelay variable, allowing you to change the “rhythm” of the phasing.

Quad Pitch Shifter (4 PITCH)

The Pitch Shifter effect transposes the pitch of the incoming signal by a fixed amount. It is useful for creating parallel harmonies, detuning, chorusing, and special effects. The Semi parameter shifts the pitch in increments of one half step, with a range of up or down one octave. The Fine parameter detunes the signal in very fine increments, with a range of up or down one half step. Also available are Delay and Feedback parameters. The Delay parameter delays the shifted signal up to 250 ms, or can be used with the Feedback parameter to produce decaying arpeggio effects. There are also Low Cut and High Cut filters in the feedback loop which can be used to alter the timbre of the sound as it repeats. The Quad Pitch Shift configuration provides two discrete pitch shifters, each with their own Pan and Level control.

Both the Quad Chorus and Quad Pitch Shifter have stereo Input and stereo Output routing. The Left Input feeds Voice 1 and the Right Input feeds Voice 4. Voices 2 and 3 are fed by a mix of the Left and Right Input. These Voices are similarly panned in the Outputs: Voices 1,2,3 and 4 are panned from hard Left to Hard Right.

Chorus:Chorus

This is a dual mono configuration with two independent mono Chorus/Flangers. Even though the configuration is called Chorus:Chorus, you can use it as a dual Flanger, or even a Chorus and a Flange. Both the controls and the I/O are separate, so stereo imaging will be maintained. By setting the left and right sides to slightly different settings, you can achieve a wide stereo image.

Chorus

This is a mono, less processor-intensive version of the Stereo Chorus effect, used in Multi Chain configurations (Chorus → Room, Room → Flange, Flange → Delay → Room) and Dual configurations (Room+Chorus).

Lezlie

With the Lezlie effect (found in the Lezlie → Room configuration), the pitch change block becomes a rotating speaker simulator. This effect was extremely popular during the 1960's and was achieved by mechanically rotating the speakers to produce complex timbral changes. The Lezlie speaker system is most often used with rock organs, but is occasionally used on other kinds of programs as well. Parameters include: Motor on/off, Speed, which can be slow or fast; and High Rotor Level, which lets you attenuate the volume of the high frequencies. When switching the Lezlie effect on and off, or when changing the speed between fast and slow, the effect will ramp rather than change abruptly, just as a true Lezlie speaker system would do. By raising the High Rotor Level, you can really make this effect scream.

Pitch Parameters

Rate

This is the rate that the delay time is modulated. It is adjustable from 0.00 to 6.47Hz.

Depth

This controls how deep the flange or chorusing will be. It affects how wide a range of delay time is swept, and is adjustable from 0-250.

Feedback (FDBK)

This is the amount of regeneration (output fed back to the input) in the Chorus/Flanger, from -99 to 99%. Negative values produce out-of-phase feedback, which has a thinner, hollow sound.

Rate, Depth and Feedback are always related, and you will probably find yourself adjusting all of them at the same time. In general, slower rates sound better with high depth settings than faster ones, and lots of feedback will sound better with lower depth settings.

THRU0 ("Thru Zero")

This control delays the input signal to better simulate tape flanging. When flanging was done using two tape machines, it was possible for one to be behind the other, catch up and then go past the other. This is called passing "through zero". The "zero" point is when both signals were in perfect synchronization.

Since the A6 is digitally simulating the flanging effect, it normally cannot provide the through zero effect. The "Thru0" parameter found in the A6's flanging effects lets you create the appearance of the effected signal passing through the zero point. It does this by actually delaying the unaffected signal by as much as 12 milliseconds (an amount virtually undetectable to the human ear). This allows the wet signal to move "behind" the dry signal as it cycles. To hear this effect properly, the **MAIN OUT** of the program must be off.

Low Pass Filter (LPF)

This filter allows you to roll off any high frequencies going into the Chorus/Flanger. This allows you to get a "warmer" flanger sound, or to simulate vintage effects.

Feedback Highpass and Lowpass Filters (FBHPF and FBLPF)

These controls filter out the high and low frequencies in the feedback loop only. By rolling off the lowest and highest frequencies, you can add lots of feedback without getting a metallic ring or low frequency thump to the sound.

Predelay

Depending on the type of effect, predelays may appear on the Parameter Strip as 1PDTIM (first predelay time of the 4-element Quad Chorus), LPDLY or RPDLY (left and right predelay in a stereo chorus), and similar variables. In any case, this controls the amount of delay before the modulation effect. If you set it below 15mS, you get a Flanger. If you set it for 15 mS or more, you get a Chorus. The Predelay range is typically up to 250mS.

Wave

The Wave parameter sets the waveform of the Chorus/Flanger's sweep, either Sine or Triangle.

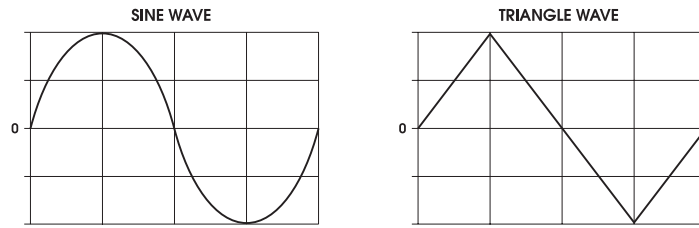

Triggered Flange

The Flanger effects can be Triggered by the input audio signal. This allows you to start the flanger at the top of the measure and other rhythmic effects. It starts the "sweep" of a flanger from the same point whenever it is triggered, and then runs until the next time you trigger it.

FLANGER SHAPE

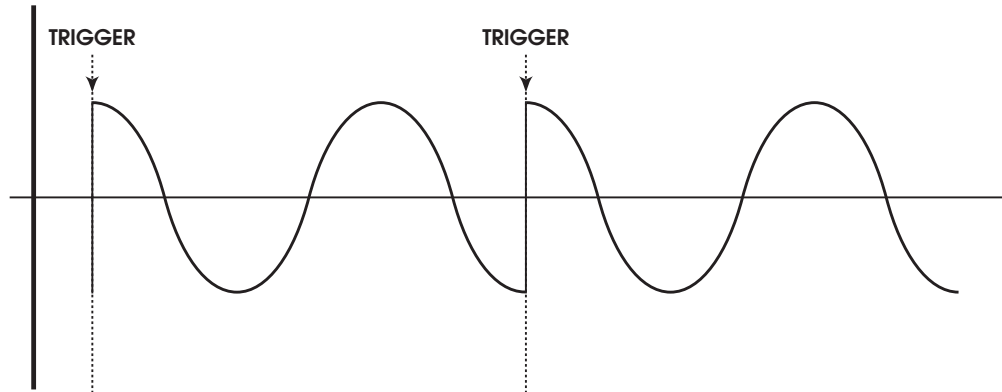

INPUT SIGNAL

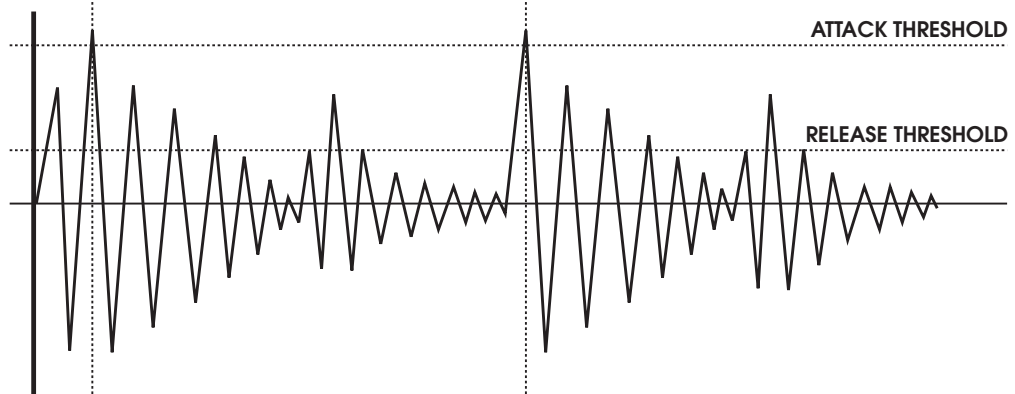

This function is controlled by three parameters:

- TRIG** This selects which input to monitor to begin triggering. The choices are OFF, Left, Right, or L&R.
- ATTACK** This parameter sets the level where the flange will “trigger” or reset. When the audio goes above this level, the flanger will begin its sweep.
- RELEASE** This is the level where the flanger stops listening to the input. When the flanger is triggered, it won’t trigger again until the input signal falls below the Release level then goes above the Attack level.

Width (Quad Chorus only)

The Width parameter adjusts the stereo width of the Quad Chorus output. A setting of 99% is full stereo, 0% is mono, and -99% is reverse stereo (The left input feeding voice 1 will be panned right).

Level (2LEVEL and 3LEVEL, Quad Chorus only)

The level of Voices 2 and 3. 1 and 4 are always set to 100%.

Motor, Speed, High Rotor Level (Lezlie only)

These three parameters control the sound of the rotary speaker simulation. Motor turns the spinning effect on or off, but does not bypass the effect - it will still be phased and filtered with the rotor on, frozen in its pan position. Speed toggles between Fast and Slow. On true rotary speakers, an organ player often switches between these speeds during a performance. High Rotor Level affects the tone of the effect. A rotary speaker usually has two segments: a spinning horn for high frequencies and a woofer firing into a spinning “scoop” for low frequencies. This parameter simulates moving a microphone closer to the high rotor.

TABLE OF DIGITAL EFFECTS PARAMETERS

The following chart lists the parameters found on each page of each configuration. Use this as a road map to locate a specific parameter you want to edit.

| CONFIG NAME | DISPLAY | | PARAMETER DISPLAY | PARAMETER NAME | RANGE |
|-------------|---------|--------|-------------------|-------------------------------|----------------------|
| | MOD | PAGE | | | |
| Large Hall | → | CONFIG | SEND | Send (Input Level from Voice) | 0.00-100.00 |
| | | | | OUT | Effects Output Level |
| | | PARAM1 | DECAY | Reverb Decay Time | 1.33 - 229 sec |
| | | | BOOST | Bass Boost | 0 - 255 |
| | | | BASSF | Bass Boost Frequency | off, 29Hz - 41.3KHz |
| | | | LPF | Input Low Pass Filter | off, 29Hz - 41.3KHz |
| | | | DENS | Reverb Density | 0 - 100% |
| | | | DIFF | Reverb Diffusion | 0 - 100% |
| | | PARAM2 | PDTIME | Pre-Delay Time | 0 - 250 msec |
| | | | PDMIX | Pre-Delay Mix | 0 - 100% |
| | | | LDAMP | Low Frequency Damping | off, 29Hz - 41.3KHz |
| | | | HDAMP | High Frequency Damping | off, 29 Hz - 41.3KHz |
| | | PARAM3 | SWIRL | Reverb Swirl | 0 - 50 |
| | | | DEPTH | Reverb Depth | 0 - 100% |
| | | | GATE | Gate Level | 0 - 100 |
| | | | HOLD | Gate Hold Time | 0 - 500 msec |
| | | | RELEAS | Gate Release Time | 0 - 500 msec |
| Hall Reverb | → | CONFIG | SEND | Send (Input Level from Voice) | 0.00-100.00 |
| | | | | OUT | Effects Output Level |
| | | PARAM1 | DECAY | Reverb Decay Time | 1.33 - 229 sec |
| | | | BOOST | Bass Boost | 0 - 255 |
| | | | BASSF | Bass Boost Frequency | off, 29Hz - 41.3KHz |
| | | | LPF | Input Low Pass Filter | off, 29Hz - 41.3KHz |
| | | | DENS | Reverb Density | 0 - 100% |
| | | | DIFF | Reverb Diffusion | 0 - 100% |
| | | PARAM2 | PDTIME | Pre-Delay Time | 0 - 250 msec |
| | | | PDMIX | Pre-Delay Mix | 0 - 100% |
| | | | LDAMP | Low Frequency Damping | off, 29Hz - 41.3KHz |
| | | | HDAMP | High Frequency Damping | off, 29 Hz - 41.3KHz |
| | | | SWIRL | Reverb Swirl | 0 - 50 |
| | | | DEPTH | Reverb Depth | 0 - 100% |
| | | PARAM3 | SPREAD | Early Reflection Spread | 0 - 500 msec |
| | | | SHAPE | Early Reflection Shape | 0 - 4 |
| | | | ELEVEL | Early Reflection Level | 0 - 99 |
| | | GATE | Gate Level | 0 - 100 | |
| | | HOLD | Gate Hold Time | 0 - 500 msec | |
| | | RELEAS | Gate Release Time | 0 - 500 msec | |

Table of Digital Effects Parameters (continued)

| CONFIG NAME | DISPLAY | | PARAMETER DISPLAY | PARAMETER NAME | RANGE |
|-------------|---------|--------|-------------------|-------------------------------|---------------------|
| | MOD | PAGE | | | |
| Stereo Room | → | CONFIG | SEND | Send (Input Level from Voice) | 0.00-100.00 |
| | | | PAN | Input Pan | -100.0- +100.00 |
| | | | OUT | Effects Output Level | 0 - 100% |
| | | PARAM1 | DECAY | Reverb Decay Time | 1.33 - 229 sec |
| | | | LPF | Input Low Pass Filter | off, 29Hz - 41.3KHz |
| | | | PDTIME | Pre-Delay Time | 0 - 250 msec |
| | | | PDMIX | Pre-Delay Mix | 0 - 100% |
| | | PARAM2 | DENS | Reverb Density | 0 - 100% |
| | | | DIFF | Reverb Diffusion | 0 - 100% |
| | | | LDAMP | Low Frequency Damping | off, 29Hz - 41.3KHz |
| | | | HDAMP | High Frequency Damping | off, 29Hz - 41.3KHz |
| | | PARAM3 | SWIRL | Reverb Swirl | 0 - 50 |
| | | | WIDTH | Stereo Image Width | 0 - 99% |
| | | | GATE | Gate Level | 0 - 100 |
| | | | HOLD | Gate Hold Time | 0 - 500 msec |
| | | | RELEAS | Gate Release Time | 0 - 500 msec |
| Room Reverb | → | CONFIG | SEND | Send (Input Level from Voice) | 0.00-100.00 |
| | | | OUT | Effects Output Level | 0 - 100% |
| | | PARAM1 | DECAY | Reverb Decay Time | 1.33 - 229 sec |
| | | | LPF | Input Low Pass Filter | off, 29Hz - 41.3KHz |
| | | | PDTIME | Pre-Delay Time | 0 - 250 msec |
| | | | PDMIX | Pre-Delay Mix | 0 - 100% |
| | | | DENS | Reverb Density | 0 - 100% |
| | | | DIFF | Reverb Diffusion | 0 - 100% |
| | | PARAM2 | LDAMP | Low Frequency Damping | off, 29Hz - 41.3KHz |
| | | | HDAMP | High Frequency Damping | off, 29Hz - 41.3KHz |
| | | | SPREAD | Early Reflection Spread | 0 - 500 msec |
| | | | SHAPE | Early Reflection Shape | 0 - 4 |
| | | | ELEVEL | Early Reflection Level | 0 - 99 |
| | | PARAM3 | SWIRL | Reverb Swirl | 0 - 50 |
| | | | DEPTH | Reverb Depth | 0 - 100% |
| | | | GATE | Gate Level | 0 - 100 |
| | | HOLD | Gate Hold Time | 0 - 500 msec | |
| | | RELEAS | Gate Release Time | 0 - 500 msec | |

| CONFIG NAME | DISPLAY MOD | PAGE | PARAMETER DISPLAY | PARAMETER NAME | RANGE |
|------------------------------|-------------------|--------------------------|-------------------------|-------------------------------|---------------------|
| Chamber AND Ambience | → | CONFIG | SEND | Send (Input Level from Voice) | 0.00-100.00 |
| | | | OUT | Effects Output Level | 0 - 100% |
| | PARAM1 | DECAY | Reverb Decay Time | 1.33 - 229 sec | |
| | | LPF | Input Low Pass Filter | off, 29Hz - 41.3KHz | |
| | | PDTIME | Pre-Delay Time | 0 - 250 msec | |
| | | PDMIX | Pre-Delay Mix | 0 - 100% | |
| | | DENS | Reverb Density | 0 - 100% | |
| | | DIFF | Reverb Diffusion | 0 - 100% | |
| | | PARAM2 | LDAMP | Low Frequency Damping | off, 29Hz - 41.3KHz |
| | HDAMP | | High Frequency Damping | off, 29Hz - 41.3KHz | |
| | SPREAD | | Early Reflection Spread | 0 - 500 msec | |
| | SHAPE | | Early Reflection Shape | 0 - 4 | |
| | PARAM3 | ELEVEL | Early Reflection Level | 0 - 99 | |
| | | SWIRL | Reverb Swirl | 0 - 50 | |
| | | DEPTH | Reverb Depth | 0 - 100% | |
| | | GATE | Gate Level | 0 - 100 | |
| | | HOLD | Gate Hold Time | 0 - 500 msec | |
| RELEAS | Gate Release Time | 0 - 500 msec | | | |
| Large Plate AND Plate | → | CONFIG | SEND | Send (Input Level from Voice) | 0.00-100.00 |
| | | | OUT | Effects Output Level | 0 - 100% |
| | PARAM1 | DECAY | Reverb Decay Time | 567 msec - 61.6 sec | |
| | | LSHELF | Low Frequency Shelf | 0 - 255 | |
| | | HPF | Input High-Pass Filter | off, 29Hz - 41.3KHz | |
| | | LPF | Input Low-Pass Filter | off, 29Hz - 41.3KHz | |
| | | DENS | Reverb Density | 0 - 100% | |
| | PARAM2 | DIFF | Reverb Diffusion | 0 - 100% | |
| | | PDTIME | Pre-Delay Time | 0 - 250 msec | |
| | | PDMIX | Pre-Delay Mix | 0 - 100% | |
| | | LDAMP | Low Frequency Damping | off, 29Hz - 41.3KHz | |
| | PARAM3 | HDAMP | High Frequency Damping | off, 29Hz - 41.3KHz | |
| | | SWIRL | Reverb Swirl | 0 - 50 | |
| | | DEPTH | Reverb Depth | 0 - 100% | |
| | | GATE | Reverb Gate | off, 1 - 100% | |
| | | HOLD | Reverb Gate Hold Time | 0 - 500 msec | |
| | RELEAS | Reverb Gate Release Time | 0 - 500 msec | | |

Table of Digital Effects Parameters (continued)

| CONFIG NAME | DISPLAY | | PARAMETER DISPLAY | PARAMETER NAME | RANGE |
|-------------|---------|--------|-------------------|-------------------------------|---------------------|
| | MOD | PAGE | | | |
| Room + Hall | → | CONFIG | SEND | Send (Input Level from Voice) | 0.00-100.00 |
| | | | BLEND | Input Blend | ±100.00 |
| | | | RM OUT | Room Output Level | 0 - 100% |
| | | | HL OUT | Hall Output Level | 0 - 100% |
| | | ROOM1 | DECAY | Room Reverb Decay Time | 1.00 - 75.8 sec |
| | | | LPF | Room Input Low-Pass Filter | off, 29Hz - 41.3KHz |
| | | | PDTIME | Room Pre-Delay Time | 0 - 250 msec |
| | | | PDMIX | Room Pre-Delay Mix | 0 - 100% |
| | | ROOM2 | DENS | Room Reverb Density | 0 - 100% |
| | | | DIFF | Room Reverb Diffusion | 0 - 100% |
| | | | LDAMP | Room Low Frequency Damping | off, 29Hz - 41.3KHz |
| | | | HDAMP | Room High Frequency Damping | off, 29Hz - 41.3KHz |
| | | HALL1 | DECAY | Hall Reverb Decay Time | 1.97 - 135 sec |
| | | | BOOST | Hall Bass Boost | 0 - 255 |
| | | | BASSF | Hall Bass Boost Frequency | off, 29Hz - 41.3KHz |
| | | | LPF | Hall Input Low-Pass Filter | off, 29Hz - 41.3KHz |
| | | HALL2 | DENS | Reverb Density | 0 - 100% |
| | | | DIFF | Reverb Diffusion | 0 - 100% |
| | | | PDTIME | Pre-Delay Time | 0 - 250 msec |
| | | | PDMIX | Pre-Delay Mix | 0 - 100% |

Table of Digital Effects Parameters (continued)

| CONFIG NAME | DISPLAY MOD | PAGE | PARAMETER DISPLAY | PARAMETER NAME | RANGE |
|--------------|-------------|--------|-------------------|-------------------------------|---------------------|
| Room + Plate | → | CONFIG | SEND | Send (Input Level from Voice) | 0.00-100.00 |
| | | | BLEND | Input Blend | ±100.00 |
| | | ROOM1 | RM OUT | Room Output Level | 0 - 100% |
| | | | PL OUT | Hall Output Level | 0 - 100% |
| | | | DECAY | Room Reverb Decay Time | 1.00 - 75.8 sec |
| | | | LPF | Room Input Low-Pass Filter | off, 29Hz - 41.3KHz |
| | | | PDTIME | Room Pre-Delay Time | 0 - 250 msec |
| | | | PDMIX | Room Pre-Delay Mix | 0 - 100% |
| | | ROOM2 | DENS | Room Reverb Density | 0 - 100% |
| | | | DIFF | Room Reverb Diffusion | 0 - 100% |
| | | | LDAMP | Room Low Frequency Damping | off, 29Hz - 41.3KHz |
| | | | HDAMP | Room High Frequency Damping | off, 29Hz - 41.3KHz |
| | | PLATE1 | DECAY | Plate Reverb Decay Time | 567 msec - 61.6 sec |
| | | | LSHELF | Low Frequency Shelf | 0 - 255 |
| | | | HPF | Input High-Pass Filter | off, 29Hz - 41.3KHz |
| | | | LPF | Input Low-Pass Filter | off, 29Hz - 41.3KHz |
| | | | DENS | Reverb Density | 0 - 100% |
| | | | DIFF | Reverb Diffusion | 0 - 100% |
| | | PLATE2 | PDTIME | Pre-Delay Time | 0 - 250 msec |
| | | | PDMIX | Pre-Delay Mix | 0 - 100% |
| | | | LDAMP | Low Frequency Damping | off, 29Hz - 41.3KHz |
| | | | HDAMP | High Frequency Damping | off, 29Hz - 41.3KHz |

Table of Digital Effects Parameters (continued)

| CONFIG NAME | DISPLAY | | PARAMETER DISPLAY | PARAMETER NAME | RANGE |
|--------------|---------|--------|-------------------|-------------------------------|---------------------|
| | MOD | PAGE | | | |
| Plate + Hall | → | CONFIG | SEND | Send (Input Level from Voice) | 0.00-100.00 |
| | | | BLEND | Input Blend | ±100.00 |
| | | | PL OUT | Room Output Level | 0 - 100% |
| | | | HL OUT | Hall Output Level | 0 - 100% |
| | | PLATE1 | DECAY | Plate Reverb Decay Time | 567 msec - 61.6 sec |
| | | | LSHELF | Low Frequency Shelf | 0 - 255 |
| | | | HPF | Input High-Pass Filter | off, 29Hz - 41.3KHz |
| | | | LPF | Input Low-Pass Filter | off, 29Hz - 41.3KHz |
| | | | DENS | Reverb Density | 0 - 100% |
| | | | DIFF | Reverb Diffusion | 0 - 100% |
| | | PLATE2 | PDTIME | Pre-Delay Time | 0 - 250 msec |
| | | | PDMIX | Pre-Delay Mix | 0 - 100% |
| | | | LDAMP | Low Frequency Damping | off, 29Hz - 41.3KHz |
| | | | HDAMP | High Frequency Damping | off, 29Hz - 41.3KHz |
| | | HALL1 | DECAY | Hall Reverb Decay Time | 1.97 - 135 sec |
| | | | BOOST | Hall Bass Boost | 0 - 255 |
| | | | BFREQ | Hall Bass Boost Frequency | off, 29Hz - 41.3KHz |
| | | | LPF | Hall Input Low-Pass Filter | off, 29Hz - 41.3KHz |
| | | HALL2 | DENS | Reverb Density | 0 - 100% |
| | | | DIFF | Reverb Diffusion | 0 - 100% |
| | | PDTIME | Pre-Delay Time | 0 - 250 msec | |
| | | PDMIX | Pre-Delay Mix | 0 - 100% | |
| Nonlinear | → | CONFIG | SEND | Send (Input Level from Voice) | 0.00-100.00 |
| | | | OUT | Effects Output Level | 0 - 100% |
| | | PARAM1 | TIME | Nonlinear Reverb Time | 100 - 600 msec |
| | | | LPF | Input Low Pass Filter | off, 29Hz - 41.3KHz |
| | | | PDTIME | Pre-Delay Time | 0 - 250 msec |
| | | | PDMIX | Pre-Delay Mix | 0 - 100% |
| | | PARAM2 | DIR | Reverb Direction | FORWARD, REVERSE |
| | | | DENS | Reverb Density | 0 - 100% |
| | | DIFF | Reverb Diffusion | 0 - 100% | |

Table of Digital Effects Parameters (continued)

| CONFIG NAME | DISPLAY | | PARAMETER DISPLAY | PARAMETER NAME | RANGE |
|-----------------|---------|--------|-------------------|-------------------------------------|----------------------|
| | MOD | PAGE | | | |
| Mono Delay | → | CONFIG | SEND | Send (Input Level from Voice) | 0.00-100.00 |
| | | | | OUT | Effects Output Level |
| | | PARAM1 | 100MS | Delay Time Hundreds of milliseconds | 0 - 54 |
| | | | 10MS | Delay Time Tens Digit | 0 - 9 |
| | | | 1MS | Delay Time Ones Digit | 0 - 9 |
| | | | FDBK | Deay Feedback | - 99% to + 99% |
| | | | LOCUT | Low Frequency Cutoff | off, 29Hz - 41.3KHz |
| | | | HICUT | Hi Frequency Cutoff | off, 29Hz - 41.3KHz |
| | | PARAM2 | DENS | Reflection Density | 0 - 100% |
| | | | RATE | Delay Modulation Rate | 0 - 6.47Hz |
| | | | DEPTH | Delay Modulation Depth | 0 - 250 msec |
| | | PARAM3 | TREMR | Tremelo Rate | 0 - 6.47Hz |
| | | | TREMD | Tremelo Depth | 0 - 100% |
| | | | PANR | Pan Rate | 0 - 6.47Hz |
| | | PAND | Pan Depth | 0 - 100% | |
| Ping Pong Delay | → | CONFIG | SEND | Send (Input Level from Voice) | 0.00-100.00 |
| | | | | OUT | Effects Output Level |
| | | PARAM1 | 100MS | Delay Time Hundreds of milliseconds | 0 - 54 |
| | | | 10MS | Delay Time Tens Digit | 0 - 9 |
| | | | 1MS | Delay Time Ones Digit | 0 - 9 |
| | | | FDBK | Deay Feedback | - 99% to + 99% |
| | | | LDAMP | Low Frequency Damping | off, 29Hz - 41.3KHz |
| | | | HDAMP | High Frequency Damping | off, 29Hz - 41.3KHz |
| | | PARAM2 | DENS | Reflection Density | 0 - 100% |
| | | | | | |

Table of Digital Effects Parameters (continued)

| CONFIG NAME | DISPLAY | | PARAMETER DISPLAY | PARAMETER NAME | RANGE |
|-----------------|---------|--------|-------------------|--|----------------------|
| | MOD | PAGE | | | |
| Multi Tap Delay | → | CONFIG | SEND | Send (Input Level from Voice) | 0.00-100.00 |
| | | | OUT | Effects Output Level | 0 - 100% |
| | | PARAM1 | 1TIME | Delay Time (First tap) | 0 - 250 ms |
| | | | 1LEVEL | Delay Tap Output Level | 0 - 99 |
| | | | 1PAN | Tap Pan | ± 50 |
| | | | 1FDBK | Delay Feedback | - 99% to + 99% |
| | | | PARAM2 | 2TIME | Delay Time (2nd tap) |
| | | PARAM2 | 2LEVEL | Delay Tap Output Level | 0 - 99 |
| | | | 2PAN | Tap Pan | ± 50 |
| | | | 2FDBK | Delay Feedback | - 99% to + 99% |
| | | PARAM3 | 3TIME | Delay Time (3rd tap) | 0 - 250 ms |
| | | | 3LEVEL | Delay Tap Output Level | 0 - 99 |
| | | | 3PAN | Tap Pan | ± 50 |
| | | | 3FDBK | Delay Feedback | - 99% to + 99% |
| | | | MFDBK | Master Feedback Scaler (controls all) | 0 - 100 |
| | | PARAM4 | 4TIME | Delay Time (4th tap) | 0 - 250 ms |
| | | | 4LEVEL | Delay Tap Output Level | 0 - 99 |
| | | | 4PAN | Tap Pan | ± 50 |
| | | | 4FDBK | Delay Feedback | - 99% to + 99% |
| | | | LOCUT | Low Frequency Cutoff | off, 29Hz - 41.3KHz |
| | | PARAM5 | 5TIME | Delay Time (4th tap) | 0 - 250 ms |
| | | | 5LEVEL | Delay Tap Output Level | 0 - 99 |
| | | | 5PAN | Tap Pan | ± 50 |
| | | | 5FDBK | Delay Feedback | - 99% to + 99% |
| | | | HICUT | Hi Frequency Cutoff | off, 29Hz - 41.3KHz |

Table of Digital Effects Parameters (continued)

| CONFIG NAME | DISPLAY | | PARAMETER DISPLAY | PARAMETER NAME | RANGE | |
|-----------------------|---------|--------|-------------------|-------------------------------|---|-----------------------|
| | MOD | PAGE | | | | |
| Delay:Delay | → | CONFIG | SEND | Send (Input Level from Voice) | 0.00-100.00 | |
| | | | PAN | Input Pan | -100.0- +100.00 | |
| | | | OUT L | Left Delay Output Level | 0 - 100% | |
| | | | OUT R | Right Delay Output Level | 0 - 100% | |
| | L-DLY1 | | | 100MS | Delay Time Hundreds (LEFT) milliseconds | 0 - 24 |
| | | | | 10MS | Delay Time Tens Digit | 0 - 9 |
| | | | | 1MS | Delay Time Ones Digit | 0 - 9 |
| | | | | FDBK | Delay Feedback | - 99% to + 99% |
| | L-DLY2 | | | LOCUT | Low Frequency Cutoff | off, 29Hz - 41.3KHz |
| | | | | HICUT | Hi Frequency Cutoff | off, 29Hz - 41.3KHz |
| | | | | RATE | Delay Modulation Rate | 0 - 6.47Hz |
| | | | | DEPTH | Delay Modulation Depth | 0 - 250 msec |
| | R-DLY1 | | | 100MS | Delay Time Hundreds (RIGHT) | 0 - 24 |
| | | | | 10MS | Delay Time Tens Digit | 0 - 9 |
| | | | | 10MS | Delay Time Ones Digit | 0 - 9 |
| | | | | FDBK | Delay Feedback | - 99% to + 99% |
| | R-DLY2 | | | LOCUT | Low Frequency Cutoff | off, 29Hz - 41.3KHz |
| | | | | HICUT | Hi Frequency Cutoff | off, 29Hz - 41.3KHz |
| | | | | RATE | Delay Modulation Rate | 0 - 6.47Hz |
| | | | | DEPTH | Delay Modulation Depth | 0 - 250 msec |
| | | | WAVE | Left Modulation LFO type | TRIANGLE or SINE | |
| | | | WAVE | Right Modulation LFO type | TRIANGLE or SINE | |
| | | | WAVE | Right Modulation LFO type | TRIANGLE or SINE | |
| | | | WAVE | Right Modulation LFO type | TRIANGLE or SINE | |
| Stereo Chorus/Flanger | → | CONFIG | SEND | Send (Input Level from Voice) | 0.00-100.00 | |
| | | | PAN | Input Pan | -100.0- +100.00 | |
| | | | OUT | Effects Output Level | 0 - 100% | |
| | PARAM1 | | | RATE | Chorus/Flange Rate | 0 - 6.477 Hz |
| | | | | DEPTH | Chorus/Flange Depth | 0 - 250 |
| | | | | FDBK | Chorus/Flange Feedback | - 99% to + 99% |
| | | | | THRU0 | Through Zero | ON/OFF |
| | | | | LPF | Input Low Pass Filter | off, 29Hz - 41.3KHz |
| | PARAM2 | | | FBHPF | Feedback High-Pass Filter | off, 29Hz - 41.3KHz |
| | | | | FBLPF | Feedback Low-Pass Filter | off, 29Hz - 41.3KHz |
| | | | | PDLYL | Pre-Delay Time LEFT | 0 - 250 msec |
| | | | | PDLYR | Pre-Delay Time RIGHT | 0 - 250 msec |
| | PARAM3 | | | TRIG | Triggered Flange Input Monitor | Off, Left, Right, L&R |
| | | | | ATTACK | Trigger Attack Threshold (start) | 0 - 255 |
| | | | | RELEAS | Trigger Release Threshold | 0 - 255 |

Table of Digital Effects Parameters (continued)

| CONFIG NAME | MOD | DISPLAY PAGE | PARAMETER DISPLAY | PARAMETER NAME | RANGE |
|---------------|------------------------|-------------------------------------|-------------------|--|---------------------|
| | | | | | |
| Quad Chorus | → | CONFIG | SEND | Send (Input Level from Voice) | 0.00-100.00 |
| | | | PAN | Input Pan | -100.0- +100.00 |
| | | | OUT | Effects Output Level | 0 - 100% |
| | | PARAM1 | 1RATE | Chorus/Flange Rate (1 st tap) | 0 - 6.477 Hz |
| | | | 1DEPTH | Chorus/Flange Depth | 0 - 250 |
| | | | 1FDBK | Chorus/Flange Feedback | - 99% to + 99% |
| | | | 1WAVE | Modulation LFO type | TRIANGLE or SINE |
| | | | 1PDTIM | Pre-Delay Time | 0 - 250 msec |
| | | PARAM2 | 2RATE | Chorus/Flange Rate (2 nd tap) | 0 - 6.477 Hz |
| | | | 2DEPTH | Chorus/Flange Depth | 0 - 250 |
| | | | 2FDBK | Chorus/Flange Feedback | - 99% to + 99% |
| | | | 2WAVE | Modulation LFO type | TRIANGLE or SINE |
| | | | 2PDTIM | Pre-Delay Time | 0 - 250 msec |
| | | PARAM3 | 3RATE | Chorus/Flange Rate (3 rd tap) | 0 - 6.477 Hz |
| | | | 3DEPTH | Chorus/Flange Depth | 0 - 250 |
| | | | 3FDBK | Chorus/Flange Feedback | - 99% to + 99% |
| | | | 3WAVE | Modulation LFO type | TRIANGLE or SINE |
| | | | 3PDTIM | Pre-Delay Time | 0 - 250 msec |
| | | PARAM4 | 4RATE | Chorus/Flange Rate (4 th tap) | 0 - 6.477 Hz |
| | | | 4DEPTH | Chorus/Flange Depth | 0 - 250 |
| 4FDBK | Chorus/Flange Feedback | | - 99% to + 99% | | |
| 4WAVE | Modulation LFO type | | TRIANGLE or SINE | | |
| 4PDTIM | Pre-Delay Time | | 0 - 250 msec | | |
| PARAM5 | WIDTH | Quad Chorus Stereo Width | ± 99 | | |
| | 2LEVEL | Out Level of 2 nd Chorus | 0 - 99 | | |
| | 3LEVEL | Out Level of 3 rd Chorus | 0 - 99 | | |
| Chorus:Chorus | → | CONFIG | SEND | Send (Input Level from Voice) | 0.00-100.00 |
| | | | PAN | Input Pan | -100.0- +100.00 |
| | | | OUT L | Left Chorus Output Level | 0 - 100% |
| | | | OUT R | Right Chorus Output Level | 0 - 100% |
| | | L-CHRS1 | RATE | Chorus/Flange Rate (Left) | 0 - 6.477 Hz |
| | | | DEPTH | Chorus/Flange Depth | 0 - 250 |
| | | | FDBK | Chorus/Flange Feedback | - 99% to + 99% |
| | | | PDTIM | Pre-Delay Time | 0 - 250 msec |
| | | L-CHRS2 | LPF | Input Low Pass Filter | off, 29Hz - 41.3KHz |
| | | | FBHPF | Feedback High-Pass Filter | off, 29Hz - 41.3KHz |
| | | | FBLPF | Feedback Low-Pass Filter | off, 29Hz - 41.3KHz |
| | | | WAVE | Modulation LFO type | TRIANGLE or SINE |
| | | | THRU0 | Through Zero | ON/OFF |
| | | R-CHRS1 | RATE | Chorus/Flange Rate (Left) | 0 - 6.477 Hz |
| | | | DEPTH | Chorus/Flange Depth | 0 - 250 |
| | | | FDBK | Chorus/Flange Feedback | - 99% to + 99% |
| | | | PDTIM | Pre-Delay Time | 0 - 250 msec |
| | | R-CHRS2 | LPF | Input Low Pass Filter | off, 29Hz - 41.3KHz |
| | | | FBHPF | Feedback High-Pass Filter | off, 29Hz - 41.3KHz |
| | | | FBLPF | Feedback Low-Pass Filter | off, 29Hz - 41.3KHz |
| WAVE | Modulation LFO type | | TRIANGLE or SINE | | |
| THRU0 | Through Zero | | ON/OFF | | |

Table of Digital Effects Parameters (continued)

| CONFIG NAME | DISPLAY | | PARAMETER DISPLAY | PARAMETER NAME | RANGE | |
|--------------------|---------|--------|-------------------|-------------------------------|------------------------------|---------------------------------|
| | MOD | PAGE | | | | |
| Quad Pitch Shifter | → | CONFIG | SEND | Send (Input Level from Voice) | 0.00-100.00 | |
| | | | PAN | Input Pan | -100.0- +100.00 | |
| | | | OUT | Effects Output Level | 0 - 100% | |
| | PARAM1 | | | 1SEMI | Pitch Shift, Semitones | ± 12 semitones (2 octave range) |
| | | | | 1FINE | Pitch Shift, Fine | ± 50 cents (1 semitone range) |
| | | | | 1LEVEL | Output Level of this element | 0 - 100% |
| | | | | 1PAN | Output Pan " " " | ± 50 |
| | | | | 1PDTIM | Pre-Delay Time | 0 - 250 msec |
| | PARAM2 | | | 2SEMI | Pitch Shift, Semitones | ± 12 semitones (2 octave range) |
| | | | | 2FINE | Pitch Shift, Fine | ± 50 cents (1 semitone range) |
| | | | | 2LEVEL | Output Level of this element | 0 - 100% |
| | | | | 2PAN | Output Pan " " " | ± 50 |
| | | | | 2PDTIM | Pre-Delay Time | 0 - 250 msec |
| | PARAM3 | | | 3SEMI | Pitch Shift, Semitones | ± 12 semitones (2 octave range) |
| | | | | 3FINE | Pitch Shift, Fine | ± 50 cents (1 semitone range) |
| | | | | 3LEVEL | Output Level of this element | 0 - 100% |
| | | | | 3PAN | Output Pan " " " | ± 50 |
| | | | | 3PDTIM | Pre-Delay Time | 0 - 250 msec |
| | PARAM4 | | | 4SEMI | Pitch Shift, Semitones | ± 12 semitones (2 octave range) |
| | | | | 4FINE | Pitch Shift, Fine | ± 50 cents (1 semitone range) |
| 4LEVEL | | | | Output Level of this element | 0 - 100% | |
| 4PAN | | | | Output Pan " " " | ± 50 | |
| 4PDTIM | | | | Pre-Delay Time | 0 - 250 msec | |
| Lezlie > Room | → | CONFIG | SEND | Send (Input Level from Voice) | 0.00-100.00 | |
| | | | MIX | Input Mix of Room | 0.00-100.00 | |
| | | | OUT | Effect Chain Output Level | 0 - 100% | |
| | LEZLE1 | | | MOTOR | Rotary Motor On/Off | ON - OFF |
| | | | | SPEED | Motor Speed | FAST or SLOW |
| | | | | HIROT | High Rotor Level | 0 - 250 |
| | ROOM1 | | | DECAY | Room Reverb Decay Time | 100 -8153 |
| | | | | LPF | Room Input Low-Pass Filter | off, 29Hz - 41.3KHz |
| | | | | PDTIME | Room Pre-Delay Time | 0 - 250 msec |
| | | | | PDMIX | Room Pre-Delay Mix | 0 - 100% |
| | ROOM2 | | | DENS | Room Reverb Density | 0 - 100% |
| | | | | DIFF | Room Reverb Diffusion | 0 - 100% |
| | | | | LDAMP | Room Low Frequency Damping | off, 29Hz - 41.3KHz |
| | | | | HDAMP | Room High Frequency Damping | off, 29Hz - 41.3KHz |
| | | | | GATE | Room Gate Hold Time | 0 - 500 msec |

Table of Digital Effects Parameters (continued)

| CONFIG NAME | DISPLAY | | PARAMETER DISPLAY | PARAMETER NAME | RANGE | | |
|--------------|---------------|------------------------|---------------------|-------------------------------|-------------------------------------|---------------------------|--------------|
| | MOD | PAGE | | | | | |
| Delay > Room | → | CONFIG | SEND | Send (Input Level from Voice) | 0.00-100.00 | | |
| | | | MIX | Input Mix of Room | 0.00-100.00 | | |
| | | | OUT | Effect Chain Output Level | 0 - 100% | | |
| | DELAY1 | | | 100MS | Delay Time Hundreds of milliseconds | 0 - 24 | |
| | | | | 10MS | Delay Time Tens Digit | 0 - 9 | |
| | | | | 1MS | Delay Time Ones Digit | 0 - 9 | |
| | | | | FDBK | Delay Feedback | - 99% to + 99% | |
| | | | | DELAY2 | | | LOCUT |
| | HICUT | Hi Frequency Cutoff | off, 29Hz - 41.3KHz | | | | |
| | DENS | Reflection Density | 0 - 100% | | | | |
| | RATE | Delay Modulation Rate | 0 - 6.47Hz | | | | |
| | DEPTH | Delay Modulation Depth | 0 - 250 msec | | | | |
| | DELAY3 | | | TREMR | Tremelo Rate | 0 - 6.47Hz | |
| | | | | TREMD | Tremelo Depth | 0 - 100% | |
| | | | | PANR | Pan Rate | 0 - 6.47Hz | |
| | | | | PAND | Pan Depth | 0 - 100% | |
| | ROOM1 | | | DECAY | Room Reverb Decay Time | 1.00 - 75.8 sec | |
| | | | | LPF | Room Input Low-Pass Filter | off, 29Hz - 41.3KHz | |
| | | | | DENS | Room Reverb Density | 0 - 100% | |
| | | | | DIFF | Room Reverb Diffusion | 0 - 100% | |
| | ROOM2 | | | GATE | Room Gate Level | 0 - 100 | |
| | | | | HOLD | Room Gate Hold Time | 0 - 500 msec | |
| | | | | RELEAS | Room Gate Release Time | 0 - 500 msec | |
| | Chorus > Room | → | CONFIG | SEND | Send (Input Level from Voice) | 0.00-100.00 | |
| | | | | MIX | Input Mix of Room | 0.00-100.00 | |
| | | | | OUT | Effect Chain Output Level | 0 - 100% | |
| | | CHORS1 | | | LRATE | Chorus/Flange Rate (Left) | 0 - 6.477 Hz |
| | | | | | LDEPTH | Chorus/Flange Depth | 0 - 250 |
| LFDBK | | | | | Chorus/Flange Feedback | - 99% to + 99% | |
| LPDLY | | | | | Pre-Delay Time | 0 - 250 msec | |
| CHORS2 | | | | RRATE | Chorus/Flange Rate (Right) | 0 - 6.477 Hz | |
| | | | | RDEPTH | Chorus/Flange Depth | 0 - 250 | |
| | | | | RFDBK | Chorus/Flange Feedback | - 99% to + 99% | |
| | | | | RPDLY | Pre-Delay Time | 0 - 250 msec | |
| CHORS3 | | | | CLPF | Chorus Input Low Pass Filter | off, 29Hz - 41.3KHz | |
| | | | | CFBHPF | Chorus Feedback High-Pass Filter | off, 29Hz - 41.3KHz | |
| | | | | CFBLPF | Chorus Feedback Low-Pass Filter | off, 29Hz - 41.3KHz | |
| ROOM1 | | | | DECAY | Room Reverb Decay Time | 100 -8153 | |
| | | | | RLPF | Room Input Low-Pass Filter | off, 29Hz - 41.3KHz | |
| | | | | PDTIME | Room Pre-Delay Time | 0 - 250 msec | |
| | | | | PDMIX | Room Pre-Delay Mix | 0 - 100% | |
| ROOM2 | | | | DENS | Room Reverb Density | 0 - 100% | |
| | | | | DIFF | Room Reverb Diffusion | 0 - 100% | |
| | | | | GATE | Room Gate Hold Time | 0 - 500 msec | |

Table of Digital Effects Parameters (continued)

| CONFIG NAME | DISPLAY MOD | PAGE | PARAMETER DISPLAY | PARAMETER NAME | RANGE |
|---------------|--------------------|---------------------------------|-------------------|----------------------------------|--------------------------------|
| Room > Flange | → | CONFIG | SEND | Send (Input Level from Voice) | 0.00-100.00 |
| | | | MIX | Input Mix of Room | 0.00-100.00 |
| | | | OUT | Effect Chain Output Level | 0 - 100% |
| | | ROOM1 | DECAY | Room Reverb Decay Time | 100 -81.53 |
| | | | LPF | Room Input Low-Pass Filter | off, 29Hz - 41.3KHz |
| | | | PDTIME | Room Pre-Delay Time | 0 - 250 msec |
| | | | PDMIX | Room Pre-Delay Mix | 0 - 100% |
| | | ROOM2 | DENS | Room Reverb Density | 0 - 100% |
| | | | DIFF | Room Reverb Diffusion | 0 - 100% |
| | | FLANG1 | RATE | Chorus/Flange Rate (Left) | 0 - 6.477 Hz |
| | | | DEPTH | Chorus/Flange Depth | 0 - 250 |
| | | | FDBK | Chorus/Flange Feedback | - 99% to + 99% |
| | | FLANG2 | PDTIME | Pre-Delay Time | 0 - 250 msec |
| | | | THRU0 | Through Zero | ON/OFF |
| | | | LPF | Flange Input Low Pass Filter | off, 29Hz - 41.3KHz |
| | | | FBHPF | Flange Feedback High-Pass Filter | off, 29Hz - 41.3KHz |
| | | | FBLPF | Chorus Feedback Low-Pass Filter | off, 29Hz - 41.3KHz |
| | | | FLANG3 | TRIG | Triggered Flange Input Monitor |
| | | | ATTACK | Trigger Attack Threshold (start) | 0 - 255 |
| | | | RELEAS | Trigger Release Threshold | 0 - 255 |
| | | Flange > Delay > Room (MULTI 3) | → | CONFIG | SEND |
| MIX 1 | Input Mix of Delay | | | | 0.00-100.00 |
| MIX 2 | Input Mix of Room | | | | 0.00-100.00 |
| FLANG1 | OUT | | | Effect Chain Output Level | 0 - 100% |
| | RATE | | | Chorus/Flange Rate (Left) | 0 - 6.477 Hz |
| | DEPTH | | | Chorus/Flange Depth | 0 - 250 |
| FLANG2 | FDBK | | | Chorus/Flange Feedback | - 99% to + 99% |
| | PDTIME | | | Pre-Delay Time | 0 - 250 msec |
| | THRU0 | | | Through Zero | ON/OFF |
| | LPF | | | Flange Input Low Pass Filter | off, 29Hz - 41.3KHz |
| | FBHPF | | | Flange Feedback High-Pass | off, 29Hz - 41.3KHz |
| | FBLPF | | | Flange Feedback Low-Pass | off, 29Hz - 41.3KHz |
| DELAY | TRIG | | | Triggered Flange Input Monitor | Off, Left, Right, L&R |
| | ATTACK | | | Trigger Attack Threshold (start) | 0 - 255 |
| | RELEAS | | | Trigger Release Threshold | 0 - 255 |
| ROOM1 | DELAY | | | Delay Time | 0 - 500 ms |
| | FDBK | | | Delay Feedback | - 99% to + 99% |
| | HICUT | | | Hi Frequency Cutoff | off, 29Hz - 41.3KHz |
| | DECAY | | | Room Reverb Decay Time | 1.00 -81.53 secs. |
| ROOM2 | LPF | | | Room Input Low-Pass Filter | off, 29Hz - 41.3KHz |
| | PDTIME | | | Room Pre-Delay Time | 0 - 250 msec |
| | PDMIX | Room Pre-Delay Mix | 0 - 100% | | |
| | DENS | Room Reverb Density | 0 - 100% | | |
| | DIFF | Room Reverb Diffusion | 0 - 100% | | |
| | GATE | Room Gate Hold Time | 0 - 500 msec | | |

Table of Digital Effects Parameters (continued)

| CONFIG NAME | DISPLAY MOD | PAGE | PARAMETER DISPLAY | PARAMETER NAME | RANGE |
|--------------|-------------|--------|-------------------|-------------------------------|---------------------|
| Room + Delay | → | CONFIG | SEND | Send (Input Level from Voice) | 0.00-100.00 |
| | | | BLEND | Input Blend | ±100.00 |
| | | | RM OUT | Room Output Level | 0 - 100% |
| | | | DL OUT | Delay Output Level | 0 - 100% |
| | | ROOM1 | DECAY | Room Reverb Decay Time | 1.00 -81.53 secs. |
| | | | LPF | Room Input Low-Pass Filter | off, 29Hz - 41.3KHz |
| | | | DENS | Room Reverb Density | 0 - 100% |
| | | | DIFF | Room Reverb Diffusion | 0 - 100% |
| | | ROOM2 | GATE | Room Gate Level | 0 - 100 |
| | | | HOLD | Room Gate Hold Time | 0 - 500 msec |
| | | | RELEAS | Room Gate Release Time | 0 - 500 msec |
| | | DELAY1 | 100MS | Delay Time Hundreds | 0 - 24 |
| | | | 10MS | Delay Time Tens Digit | 0 - 9 |
| | | | 1MS | Delay Time Ones Digit | 0 - 9 |
| | | | FDBK | Delay Feedback | - 99% to + 99% |
| | | DELAY2 | LOCUT | Low Frequency Cutoff | off, 29Hz - 41.3KHz |
| | | | HICUT | Hi Frequency Cutoff | off, 29Hz - 41.3KHz |
| | | | DENS | Reflection Density | 0 - 100% |
| | | | RATE | Delay Modulation Rate | 0 - 6.47Hz |
| | | | DEPTH | Delay Modulation Depth | 0 - 250 msec |
| | | DELAY3 | TREMR | Tremelo Rate | 0 - 6.47Hz |
| | | | TREMD | Tremelo Depth | 0 - 100% |
| | | | PANR | Pan Rate | 0 - 6.47Hz |
| | | | PAND | Pan Depth | 0 - 100% |

Table of Digital Effects Parameters (continued)

| CONFIG NAME | DISPLAY MOD | PAGE | PARAMETER DISPLAY | PARAMETER NAME | RANGE |
|---------------|---------------------------------|---------|---------------------|--|----------------------------------|
| Room + Chorus | → | CONFIG | SEND | Send (Input Level from Voice) | 0.00-100.00 |
| | | | BLEND | Input Blend | ±100.00 |
| | | | RM OUT | Room Output Level | 0 - 100% |
| | | | CH OUT | Chorus Output Level | 0 - 100% |
| | | ROOM1 | DECAY | Room Reverb Decay Time | 1.00 -81.53 secs. |
| | | | LPF | Room Input Low-Pass Filter | off, 29Hz - 41.3KHz |
| | | | PDTIME | Room Pre-Delay Time | 0 - 250 msec |
| | | | PDMIX | Room Pre-Delay Mix | 0 - 100% |
| | | ROOM2 | DENS | Room Reverb Density | 0 - 100% |
| | | | DIFF | Room Reverb Diffusion | 0 - 100% |
| | | | HOLD | Room Gate Hold Time | 0 - 500 msec |
| | | CHORS1 | LRATE | Chorus/Flange Rate (1 st tap) | 0 - 6.477 Hz |
| | | | LDEPTH | Chorus/Flange Depth | 0 - 250 |
| | | | LFDBK | Chorus/Flange Feedback | - 99% to + 99% |
| | | | LPDTIM | Pre-Delay Time | 0 - 250 msec |
| | | CHORS2 | RRATE | Chorus/Flange Rate (2 nd tap) | 0 - 6.477 Hz |
| | | | RDEPTH | Chorus/Flange Depth | 0 - 250 |
| | | | RFDBK | Chorus/Flange Feedback | - 99% to + 99% |
| | | | RPDTIM | Pre-Delay Time | 0 - 250 msec |
| | | CHORS3 | LPF | Chorus Input Low Pass Filter | off, 29Hz - 41.3KHz |
| | | | FBHPF | Chorus Feedback High-Pass Filter | off, 29Hz - 41.3KHz |
| FBLPF | Chorus Feedback Low-Pass Filter | | off, 29Hz - 41.3KHz | | |
| Room + Flange | → | CONFIG | SEND | Send (Input Level from Voice) | 0.00-100.00 |
| | | | BLEND | Input Blend | ±100.00 |
| | | | RM OUT | Room Output Level | 0 - 100% |
| | | | FL OUT | Flange Output Level | 0 - 100% |
| | | ROOM1 | DECAY | Room Reverb Decay Time | 1.00 -81.53 secs. |
| | | | LPF | Room Input Low-Pass Filter | off, 29Hz - 41.3KHz |
| | | | PDTIME | Room Pre-Delay Time | 0 - 250 msec |
| | | | PDMIX | Room Pre-Delay Mix | 0 - 100% |
| | | ROOM2 | DENS | Room Reverb Density | 0 - 100% |
| | | | DIFF | Room Reverb Diffusion | 0 - 100% |
| | | | HOLD | Room Gate Hold Time | 0 - 500 msec |
| | | FLANG1 | RATE | Chorus/Flange Rate (1 st tap) | 0 - 6.477 Hz |
| | | | DEPTH | Chorus/Flange Depth | 0 - 250 |
| | | | FDBK | Chorus/Flange Feedback | - 99% to + 99% |
| | | | PDTIM | Pre-Delay Time | 0 - 250 msec |
| | | | THRU0 | Through Zero | ON/OFF |
| | | | LPF | Flange Input Low Pass Filter | off, 29Hz - 41.3KHz |
| | | | FLANG2 | FBHPF | Flange Feedback High-Pass Filter |
| | | FBLPF | | Flange Feedback Low-Pass Filter | off, 29Hz - 41.3KHz |
| | | TRIG | | Triggered Flange Input Monitor | Off, Left, Right, L&R |
| | | ATTACK | | Trigger Attack Threshold (start) | 0 - 255 |
| RELEAS | Trigger Release Threshold | 0 - 255 | | | |

Table of Digital Effects Parameters (continued)

| CONFIG NAME | DISPLAY MOD | PAGE | PARAMETER DISPLAY | PARAMETER NAME | RANGE | |
|--------------|-------------|--------|-------------------|-------------------------------|-------------------------------------|---------------------|
| Room > Delay | → | CONFIG | SEND | Send (Input Level from Voice) | 0.00-100.00 | |
| | | | MIX | Input Blend | 0.00-100.00 | |
| | | | OUT | Effect Chain Output Level | 0.00-100.00 | |
| | | | ROOM1 | DECAY | Room Reverb Decay Time | 1.00 -81.53 secs. |
| | | | | LPF | Room Input Low-Pass Filter | off, 29Hz - 41.3KHz |
| | | | | PDTIME | Room Pre-Delay Time | 0 - 250 msec |
| | | | | PDMIX | Room Pre-Delay Mix | 0 - 100% |
| | | | ROOM2 | DENS | Room Reverb Density | 0 - 100% |
| | | | | DIFF | Room Reverb Diffusion | 0 - 100% |
| | | | | HOLD | Room Gate Hold Time | 0 - 500 msec |
| | | | DELAY1 | 100MS | Delay Time Hundreds of milliseconds | 0 - 24 |
| | | | | 10MS | Delay Time Tens Digit | 0 - 9 |
| | | | | 1MS | Delay Time Ones Digit | 0 - 9 |
| | | | | FDBK | Delay Feedback | - 99% to + 99% |
| | | | DELAY2 | LOCUT | Low Frequency Cutoff | off, 29Hz - 41.3KHz |
| | | | | HICUT | Hi Frequency Cutoff | off, 29Hz - 41.3KHz |
| | | | | DENS | Reflection Density | 0 - 100% |
| | | | | RATE | Delay Modulation Rate | 0 - 6.47Hz |
| | | | | DEPTH | Delay Modulation Depth | 0 - 250 msec |
| | | | DELAY3 | TREMR | Tremelo Rate | 0 - 6.47Hz |
| | | | | TREMD | Tremelo Depth | 0 - 100% |
| | | | PANR | Pan Rate | 0 - 6.47Hz | |
| | | | PAND | Pan Depth | 0 - 100% | |

CHAPTER 11:

MIX MODE

The basics of Mix Mode operation including how to select a Mix, change a Program within a Mix, and the complete list of Mix Parameters can be found in Chapter 2, pages 39 through 42. Setting up Splits and Layers is covered on pages 47 and 48.

WHAT IS A MIX?

Mix Mode is one of the most powerful features of the Andromeda. Although in Program Mode you can play only one Program at a time, in Mix Mode you can play up to 16 Programs at once, either from the keyboard (as layers or splits) or from an external sequencer (via 16 MIDI channels) or a combination of both. Keep in mind, however, that since the Andromeda has a total of 16 voices, a full 16-channel Mix would have only one voice per channel.

Having said that, with Mix Mode, you can do the following:

- Combine (“stack” or “layer”) different Programs so they can be played simultaneously from the keyboard. For example, stack a stabbing synth sound on top of a warm pad, adjusting the volume of each to get the mix you want.
- Split the keyboard into different zones—for example, the classic bass synth on the left-hand side of the keyboard, and a brass program on the right. You can split the keyboard into as many as 16 zones, which may overlap.
- Transmit on as many as 16 different MIDI channels simultaneously.
- Receive up to 16 MIDI channels from an external sequencer, with each channel representing a different instrument.

Or, you can have several different programs on different Mix Channels responding to the **same** MIDI channel. More on this below.

- Set the level, panning, transposition, and output assignment of each Program in a Mix.
- Enable and disable the major controllers such as Pitch Bend, Mod Wheel, Ribbon Controller, etc. individually per Channel.

MIX CHANNELS VS. MIDI CHANNELS

Most digital synthesizers (including the Alesis QS Series) assign one Program per MIDI channel in a multitimbral Mix. But while the Andromeda has 16 Mix Channels, that is **not** the same as the 16 conventional MIDI channels. Several A6 Mix Channels may be “played” by only one MIDI channel if desired. This means that if you want to play a layer of several Programs, you don’t have to clog the MIDI sequencer with duplicate tracks and messages.

For example, you could have Mix Channels 1, 2 and 3 layered together, playing to and responding to MIDI channel 8. Mix Channels 4 and 5 could be a bass layer responding to MIDI channel 9.

COMMON MIX SETTINGS FOR MIDI SEQUENCERS

The easiest way to use the A6 with a MIDI sequencer is to use one of the pre-programmed Mixes in the Preset or User banks. See the Program/Mix chart for the Mix set up for multitimbral use that's appropriate for your situation.

But if you want to start from scratch or edit an existing Mix, here are the steps:

TO MAKE A CUSTOM MULTITIMBRAL MIX:

1. Press the **MIX** button.
2. Select a Mix to start with using the **PROGRAM GROUP/NUMBER**, and **BANK** keys.

Select a Mix Channel

3. Select Mix Channel 1 by pressing the black **MIX SELECT 1/9** key.
Make sure the right side of the display window has a box that says MIX CHAN 1. If it says MIX CHN 9, press the SHIFT key and press MIX SELECT 1/9 again.
4. If the green LED above the **MIX SELECT** key isn't flashing, press it again to enable the channel.
A small box in the display should say ON and an arrow appear pointing to the current Mix Channel. The flashing LED above the switch means the Mix Channel is currently selected for editing and is ON.

Set the Keyboard parameters

5. Press soft button **5** (**KBD**).
6. If you want to play this mix channel from the keyboard*, make sure that **ENABLE** is set to ON using soft knob **4**. Set the high and low ranges using soft knobs **1** and **2**.

Set the MIDI parameters

7. Press soft button **6** (**FROG**).
8. Set the MIDI channel for this Mix Channel by turning soft knob **6** (**MIDICH**).
9. Press soft button **7** (**CNTL**). If the first parameter isn't **MID IN**, press it again. Set **MID IN** to ON using soft knob **1**.
10. If you're going to be using this Mix Channel to send note messages to the sequencer*, set **MIDOUT** (soft knob **2**) to ON.

* In most MIDI sequencer applications, you'll want to send only one MIDI channel from the keyboard, and the sequencer will be set to "echo" the MIDI notes back to the synthesizers. The sequencer will also be able to re-route a MIDI channel as you're recording. (For example, most people send only MIDI Channel 1 messages from their keyboard, and allow the computer to record the data onto other MIDI channels.) The Andromeda's **GLOBAL** mode can also affect how MIDI is handled; either generating MIDI messages without making a sound until a MIDI message is "echoed" back (local mode) or if it will not generate MIDI messages at all, regardless of the Mix settings. See pages 49 and 50, Using Global Mode/KEYBD Page Parameters.

Select a Program for the Mix Channel

11. When you're on Mix Mode's **FROG** page, the **PROGRAM GROUP/NUMBER**, and **BANK** keys may be used to change programs. You can also select a different Program by pressing soft button **2**, **DIR** (for "Directory") and scrolling through it. But be sure the currently-selected page is not **MIX**, or you will lose all your edits!

Set Controller parameters

At this point, it should be self-explanatory to go on to the **CNTL** page and decide whether you want this program to respond to various controller messages. For example, you can have a lead synth part affected by the pitch bend, while the bass patch on another Mix Channel stays steady.

Repeat on other Mix Channels

To add other Mix Channels, simply repeat steps 3-11 above, selecting different channels in step 3. Don't forget to press **STORE** along the way... a careless punch of a program button at the wrong time could take you to another Mix altogether, losing the edits you've made.

MIDI PROGRAM CHANGE MESSAGES

Note that if several different Mix Channels are on the same MIDI Channel, a Program Change message received via MIDI will make all the Mix Channels on that MIDI Channel go to the same Program...not usually a useful result. To avoid this, if you're using PgmCh messages, go to the **CNTL** page where **MIDPGM** is and turn soft knob **6** so that Mix Channel will ignore the messages.

EDITING PROGRAMS FROM MIX MODE

Especially when you're combining Programs in a stack to make a single combined sound, you may find that an individual Program needs to be "tweaked" a bit to make it sound right. You don't need to leave Mix Mode to do that. Programs are live on the front panel upon Mix Channel selection, and can be edited while the other Channels play. You may edit all Programs in a Mix as there are (of course) 16 edit buffers. You may Store an edited Program back to its Program User Bank location by simply pressing Store twice. Or, you can Store a Mix Channel Program to any location so that the original Program may be preserved.

If you have done editing of Programs in Mix Mode, you must store each Program individually, as well as storing the Mix that calls on them. If you're not sure which parameters are part of the Mix and which are part of the Programs, see pages 34 -35, **Data Banks: How the A6's Sounds Are Organized.**

Mix SOLO

You may solo a Mix Channel by pressing **SOLO** (soft button **8**) on any screen of Mix Mode. **SOLO** mode is indicated by a text box on the screen, and the **SOLO** logo will flash. In this mode, all other Mix Channels are muted, both audio and MIDI Out.

TO COPY A MIX CHANNEL FROM ANOTHER MIX:

Mix Channel complete with its effect sends and MIDI channel assignments may be copied to the Mix Edit buffer from any Mix in memory. The procedure is similar to that for copying an effect.

1. Start with the Mix you're editing (of course). Press **STORE**.
2. Press **COPY** (soft button **3**).
3. Using **TYPE** (soft knob **1**), select **MIX CHAN**.
4. Select the specific Mix you want to copy from using the **SRCBANK** and **SRCNUM** knobs (soft knobs **2** and **3**).

The name of the Mix will be shown in the display.

5. Select the **source** Mix Channel (1–16) using soft knob **4** (MIXCHN).
6. Select the **destination** Mix Channel (1–16) using soft knob **8** (MIXCHN).
MIX EDIT MIXCHAN: XX will be shown in the display.
7. Press soft button **3** (COPY).
A window will pop up asking you to press STORE to copy the effect.
8. Press **STORE**.

EFFECTS IN MIX MODE

Effects, both Digital and Analog Distortion, are stored per Mix, and can be copied from Programs or other Mixes. Note that while each individual Program has its own Effects parameters in Program Mode, these aren't brought into the Mix since there aren't 16 separate Digital Effects and Analog Distortion sections. However, you can vary the Effect Send and Pan levels from each Mix Channel.

Effects are selected and created in a Mix in the same manner as in Program, by using the Effects buttons and pages (see Chapter 10).

TO SET EFFECT SEND LEVELS FOR DIFFERENT MIX CHANNELS:

1. Select different Channels using the **MIX SELECT** and **SHIFT** keys.
2. Press the **ANALOG DISTORTION CONFIG OR DIGITAL EFFECTS CONFIG** buttons on the top panel.
3. Notice that soft knob 1's parameter title is SEND X, where X is the number of the current Mix Channel. If the Digital Effect has a PAN control, it will also show the number of the Channel.
4. Use the soft knobs to get the values you want. Note that any other changes you make besides SEND and PAN will be to the effect for the entire Mix, not just the current Channel.

TO COPY AN EFFECT FROM ANOTHER PROGRAM OR MIX:

A Digital Effects and/or Analog Distortion configuration may be copied from any Program or Mix in memory. These are copied to the Mix Edit Buffer, so you can customize them before storing them along with the current Mix.

1. Start with the Mix you're editing (of course). Press **STORE**.
2. Press **COPY** (soft button 3).
3. Select the type of effect you want to copy to the current mix using **TYPE** (soft knob 1):
 - PRG DFX to copy a Digital Effect from a Program.
 - PRG AFX to copy an Analog Distortion from a Program.
 - MIX DFX to copy a Digital Effect from a Mix.
 - MIX AFX to copy an Analog Distortion from a Mix.
4. Select the specific Program or Mix you want to copy from using the **SRCBANK** and **SRCNUM** knobs (soft knobs 2 and 3).
The name of the Program or Mix will be shown on the screen.
5. The display should show MIX EDIT BUFFER. If not, turn soft knob 6 (DSTBUF) until it does.
6. Press soft button 3 (COPY).
A window will pop up asking you to press STORE to copy the effect.
7. Press **STORE**.
Remember—even though you pressed STORE, the effect is only in the Mix Edit Buffer until you store the Mix itself to either the User Bank or a Card.

MIDI FUNCTIONS

MIDI BASICS

Before we delve into the specific MIDI functions of the A6, we'd like to provide a brief background on MIDI for those who may not be familiar with this technology.

MIDI (pronounced "MID-ee") is the acronym for **M**usical **I**nstrument **D**igital **I**nterface. It was developed and adopted by electronic musical instrument manufacturers in the early 1980s as a common system of connecting electronic musical instruments and devices so that they could share music data as well as other digital information.

Just about any device that has a microprocessor (synthesizers, samplers, sequencers and drum machines, analog and digital recorders and mixers, effects devices and computers) can share music data (notes and chords) and various digital information such as pitch bend and vibrato, sustain and volume pedal, keyboard velocity, pressure and aftertouch, patch change commands, timing data (called "MIDI Clock") and a wide variety other types of data.

Thus, virtually any musical expression that is generated by an electronic musical device could be shared in a system of MIDI devices. But we are not limited to musical applications alone. With the addition of MIDI Time Code for example, the ability to interface a music system with video production was realized. There are even stage lighting systems that use MIDI for programming light control and data storage.

A document called the *MIDI Specification* describes all possible MIDI functions and how they should work. Manufacturers use this spec when designing products so that a fairly high level of compatibility among different brands can be reasonably expected.

Generally, a manufacturer will also include a MIDI Implementation chart with each product so that you can know how MIDI was designed into that particular model. This is usually helpful to know because not every MIDI function needs to be included in every musical product. For example, certain MIDI functions that are unique to keyboard instruments are unnecessary on, say, digital effects devices. Manufacturers have the option of including whatever MIDI functions are appropriate to the product. You can find the MIDI Implementation chart for the A6 in Appendix C.

MIDI HARDWARE

MIDI instruments and devices are connected by a fairly simple system of cables. The **MIDI OUT** port transmits data from one device one-way through the cable to the receiving instrument's **MIDI IN**. You can setup each device in the system to send and respond to MIDI commands in a certain way. For example, you can tell your keyboard or guitar synth to send everything in MIDI except for Program Change commands. By the same token, you can tell your sound module to respond to any MIDI command sent to it but ignore Velocity data.

MIDI THRU simply passes data received by **MIDI IN** right back out to another device connected to it. This makes "chaining" possible in a MIDI system.

For some examples in connecting MIDI devices together, see our illustrations in **MIDI Connections** starting on page 23. This MIDI Chapter will take these basic connections and provide many examples of using your A6 to control other instruments in a MIDI system, and playing your A6 from another MIDI device.

MIDI MESSAGES

There are two types of MIDI messages that are communicated through your network of MIDI cables: *Channel* and *System*.

Channel Messages are typically the messages you'll be most concerned with for routine MIDI operations and can originate (be transmitted) from virtually any device in the system. MIDI provides 16 "Channels" through which certain MIDI data is shared among devices in the system. The communication of certain messages along Channels makes it possible to connect many devices together but allows you to specify **which devices communicate directly with each other**. For example, you could have seven MIDI devices that are all connected to each other. Two of the devices can be communicating on Channel 2, two others on Channel 9 and the remaining three on Channel 4, as one possible setup.

Channel messages are further divided into two groups: *Voice* messages and *Mode* messages. Because these messages are *channelized* (they are communicated on a designated Channel number), **they are only recognized by instruments that have been set to receive on that Channel** (or Omni On mode which tells the receiving device to respond to data from all Channels – see Mode Messages on page 251).

System Messages, on the other hand, **do not have a channel number** and can be received **by any device in a system**. This permits devices in a MIDI system to share certain data without having to be set to a particular Channel. System messages, like Channel messages, can originate from just about any MIDI device in the system. The three types of System messages are called *Real Time* messages, *Common* messages and *Exclusive* messages.

Channel Messages: Voice Messages

Each MIDI device is assigned a Basic *MIDI Channel*. This is the MIDI Channel that the instrument will use to **transmit** MIDI data and can be set to any Channel number 1 - 16. If OMNI Mode is set to OFF, this is also the MIDI Channel that the instrument will **receive** on.

This principle is not set in concrete, however. For many MIDI instruments, the ability to communicate – both transmit and receive – on **several** Channels at once is quite common. For example, certain instruments are designed such that you can set a Voice or group of voices to MIDI Channels other than the Basic Channel. This provides enormous flexibility in the way that the instrument can control other instruments in the system, or be controlled by another MIDI device. You might want to think of a device's Basic Channel as the one that other Channel settings can be based – hence the word "basic". A good place to start is a setup that instructs the unit to transmit and receive on the Basic Channel, then build from there if you need to.

The A6 is a prime example of a multiple MIDI Channel instrument in that its *Mix Channels* – ranges of MIDI notes used to define splits and layers – may be assigned a specific MIDI Channel to play from. Each of the A6's 16 Mix Channels transmit and receive on a selected MIDI Channel and allow you to specify which of its 16 voices to play. For an in-depth look at how this is implemented on the A6, see page 47, and **Chapter 11: Mix Mode**.

MIDI messages that affect your instrument's voices include:

Note On. This message communicates that a particular note is being played and corresponds to a key being pressed down; values range from 000 (the lowest possible note) to 127 (the highest possible note). Middle C is MIDI Note #60.

Note Off. Where a Note On message communicates when a note is to be played, this message tells when the key has been released. This may appear a little like overkill, but remember that we're dealing with computers here: every action requires a corresponding message to be communicated.

Velocity. A Velocity message corresponds to the *dynamics* of your playing by telling the receiving device how quickly (or slowly) a note was played. Typically, Velocity affects the loudness and brightness of the sound – playing harder makes the sound louder and brighter; playing softly makes the sound quieter and less bright. In the more elaborate products, this data can be routed to other aspects of the sound as well for some very interesting results. Velocity values range from 001 (minimum velocity) to 127 (maximum velocity). A velocity of 000 is equivalent to a Note Off message.

“Channel Pressure” and “Polyphonic Key Pressure”. These messages communicate the physical pressure applied to the keyboard after a key is played. Channel Pressure (commonly known as *Aftertouch* or *Mono Pressure*) represents the **average** amount of pressure applied by all keys. Polyphonic Key Pressure produces individual pressure messages **for each key**. As with Velocity, these functions typically affect the loudness and brightness of the sound – pressing harder can be used to make the sound louder and brighter. Also like Velocity messages, this data can be routed to affect other aspects of the sound: pressure can be used, for example, to add vibrato.

Program Change. Sending a Program Change command from a sequencer or another MIDI keyboard can change synth patches automatically. There are 128 Program Change command numbers.

Also note that not all instruments and devices number programs consistently. Some number them as 000-127, others as 001-128, and still others arrange programs in banks of 8 programs (such as A1-A8, B1-B8, C1-C8, etc.).

Pitch Bend. This “bends” a note from its standard pitch.

Continuous Controllers. This term is sometimes abbreviated “CC” and is followed by a number sign and a number, as in “CC #7”. If you look at the chart on the next page, you’ll see that “Continuous Controller # 7” controls MIDI (or Main) Volume. What we mean by “continuous” is that the controller is able “to go from 0 to 127 in increments of 1”. Although this might first appear as a rough stepping from one value to the next, the resolution of 128 increments is small enough to provide a smooth transition through this range. If this resolution is not fine enough, the manufacturer can opt to add more resolution by using a second byte to define the range. Controller #'s 32 through 63 are used for this purpose.

Footpedals, breath controllers, and modulation wheels can vary sounds as you play, thus adding expressiveness. MIDI allows for 32 continuous controllers and 58 continuous/switch controllers (which can act like continuous controllers, but some are assumed to choose between two possible states, such as on and off).

Each type of controller is stamped with its own controller identification number. Not all controller numbers have been standardized for specific functions, but the following table lists the current list of assigned controllers.

| CONTROLLER # | FUNCTION | DATA RANGE |
|---------------------|---|--------------------|
| 0 | Bank Select | 0 - 127 |
| 1 | Modulation Wheel | 0 - 127 |
| 2 | Breath Controller | 0 - 127 |
| 3 | Early DX7 Aftertouch | 0 - 127 |
| 4 | Foot Controller | 0 - 127 |
| 5 | Portamento Time | 0 - 127 |
| 6 | Data Slider | 0 - 127 |
| 7 | Main Volume | 0 - 127 |
| 8 | Balance | 0 - 127 |
| 10 | Pan | 0 - 127 |
| 11 | Expression | 0 - 127 |
| 16 | General Purpose #1 | 0 - 127 |
| 17 | General Purpose #2 | 0 - 127 |
| 18 | General Purpose #3 | 0 - 127 |
| 19 | General Purpose #4 | 0 - 127 |
| 32-63 | Least Significant Bytes (LSB), Controllers 0-31 | 0 - 127 |
| 64 | Sustain Pedal | 0 or 127 |
| 65 | Portamento On/Off | 0 or 127 |
| 66 | Sostenuto Pedal | 0 or 127 |
| 67 | Soft Pedal | 0 or 127 |
| 69 | Hold 2 | 0 or 127 |
| 80 | General Purpose #5 | 0 or 127 |
| 81 | General Purpose #6 | 0 or 127 |
| 82 | General Purpose #7 | 0 or 127 |
| 83 | General Purpose #8 | 0 or 127 |
| 91 | Reverb Depth | 0 - 127 |
| 92 | Tremolo Depth | 0 - 127 |
| 93 | Chorus Depth | 0 - 127 |
| 94 | Celeste Depth | 0 - 127 |
| 95 | Phase Depth | 0 - 127 |
| 96 | Data Increment | 0 or 127 |
| 97 | Data Decrement | 0 or 127 |
| 98 | Non-Registered Parameter MSB | 0 - 127 |
| 99 | Non-Registered Parameter LSB | 0 - 127 |
| 100 | Registered Parameter MSB | 0 - 127 |
| 101 | Registered Parameter LSB | 0 - 127 |
| 121 | Reset All Controllers | 0 |
| 122 | Local Control On/Off | 0 or 127 |
| 123 | All Notes Off | 0 |
| 124 | Omni Off | 0 |
| 125 | Omni On | 0 |
| 126 | Mono On | 0-16; 0 = Omni Off |
| 127 | Poly On | 0 |

Channel Messages: Mode Messages

There are four types of messages that determine the MIDI *Mode* of the instrument. The “mode” of a device refers to **how it will respond to incoming MIDI data**.

The four possible modes are defined by the instrument’s Receive Status – *Omni On* or *Omni Off* – and by its Voice Assignment – *Poly* or *Mono*.

The Omni On or Omni Off messages determine **how many channels** will be recognized when the instrument or device is receiving MIDI data. Omni On means that data from **all** channels will be received; Omni Off tells the receiving instrument to respond to MIDI data on **one** channel only.

The Poly and Mono messages determine the **voice assignment** of the instrument. An instrument’s *voice* is the most basic unit of sound generation. It can be an integrated circuit chip (or chips) like the A6, or can be a sampled sound in the instrument’s memory.

Each voice plays one note at a time, so the number of notes you can play at one time will be limited by the number of voices. The A6 is a 16-voice instrument so you can play up to 16 keys on its keyboard, receive up to 16 MIDI Notes, or a combination of 16 keyboard and MIDI Notes at one time.

So in Poly mode, the receiving instrument plays incoming MIDI notes **polyphonically** up to the number of voices it has (16 maximum for the A6). In Mono mode, the receiving instrument plays incoming MIDI notes **monophonically**: only one voice at a time plays in response to incoming MIDI notes.

The MIDI Specification combines the two Receive Status modes with the Voice Assignment modes and describes each as follows:

Mode 1: Omni On/Poly

The instrument responds to notes from all Channels and plays them polyphonically. This is a popular mode for many musicians in that it makes the unit play via MIDI regardless of what Channel other units in the MIDI system are set to. Most products ship from the factory with this mode enabled so that they will respond to MIDI polyphonically right out of the box.

Mode 2: Omni On/Mono

The instrument responds to notes from all Channels and plays them monophonically on one voice. This mode causes the receiving instrument to be monophonic and is the least used mode of the four.

Mode 3: Omni Off/Poly

The instrument responds to notes from one Channel only (which is set by the user) and plays them polyphonically. This is possibly the most-used mode for the majority of musicians. In most MIDI systems, each instrument is set to play polyphonically on a specific MIDI Channel.

Mode 4: Omni Off/Mono

In this mode, the receiving device is, in essence, divided into a number of monophonic instruments: each voice is assigned its own MIDI Channel and will play only one note at a time when incoming MIDI Notes are recognized.

System Messages: Real-Time Messages

Timing Clock. A tempo source (such as a sequencer) emits 24 timing messages (clocks) per quarter note. Each device synchronized to the sequencer advances by 1/24th of a quarter note when it receives the clock message, thus keeping units in sync after they've both started at the same time. Many devices subdivide this clock signal internally for higher resolution (e.g., 96 pulses per quarter note).

Start. Signals all rhythmically-based units when to start playing.

Stop. Signals all rhythmically-based units when to stop playing.

Continue. Unlike a Start command which re-starts a sequencer or drum machine from the beginning of a song each time it occurs, sending a Continue message after a Stop command will re-start units from where they were when they stopped.

Active Sensing. Active Sensing is a precautionary measure in MIDI that allows all instruments in a MIDI system to turn off any playing voices in the event that one or more MIDI cables become unplugged. Because receiving instruments wait for a Note Off command to know when a note or chord has stopped playing, yanking a MIDI cable out while notes are being played will cause receiving instruments to have any sustaining notes get "stuck on".

With Active Sensing, a message is sent from the transmitting device to all receiving devices about three times a second. Once receiving devices recognize this message, they will expect to continue to receive it. If this message stops – using our example of a MIDI cable being accidentally pulled out – the receiving instruments will perform an All Notes Off to stop any voices that might be playing at the time. When the offending cable is found and replaced, the system returns to normal.

System Reset. Every MIDI instrument and device has a *default* set of parameters (all the factory settings the unit had when you first took it out of the box). These defaults can be restored if you manually initialize the instrument (see Troubleshooting section). System Reset is the command used to accomplish this via MIDI.

System Messages: Common Messages

Song Position Pointer. This indicates how many "MIDI beats" (normally a 16th note) have elapsed since a piece started (up to 16,384 total beats or 1,024 measures in 4/4). It is primarily used to allow different sequencers and drum machines to auto-locate to each other. If you start your sequencer for example, the other devices will automatically jump to the same place in the song, whereupon all continue on together. The sequencer in the A6 does not respond to SPP.

Song Select. Intended for clock-based devices (such as drum machines and sequencers), this message tells all units in the system which Song Number to select. This handy function allows you to instruct all clock-based units in your MIDI rig to load the appropriate song data from their own internal memory remotely.

You can think of Song Select as a kind of a Program Change command for drum machines and sequencers, although Song Select commands are not channelized. In fact, drum machines and sequencers **do** have the ability to respond to Program Change commands transmitted on a specific Channel. When they do, they recall an individual drum pattern or sequence. Song Select is used to recall a Song which is typically composed of many patterns or sequences in the form of a finished song.

Tune Request. Primarily intended for analog synthesizers which need to have their oscillators tuned periodically, this command instructs all units in the system to initiate an autotune routine.

End-of-System-Exclusive Message. This byte is sent at the completion of a System Exclusive message and that tells all units in a MIDI rig that a Program or Sample dump in progress has completed.

System Messages: Exclusive Messages

System Exclusive. This message (called *SysEx* for short) is considered “exclusive” because different manufacturers send and receive data over MIDI which is intended only for that manufacturer’s equipment. For example, sending a A6 SysEx message to an Alesis DM Pro drum module won’t do anything, but the message will be understood by another A6.

System Exclusive messages most often contain the data of individual instrument programs: when synthesizer patches are transferred via SysEx, it is called a Program Dump; sound samples transferred between two like devices via the MIDI Sample Dump standard.

The System Exclusive message function of MIDI makes it possible for two or more synthesizers that are the same make and model to exchange program data. Two drum machines of the same make and model can exchange pattern and song data, much the same as two identical sequencers to exchange sequence and song data.

SysEx also makes it possible for MIDI editing using personal computers. It is often the case with complex synthesizers, drum machines and sequencers to have their functions buried in layers of display *pages* – a group of related functions that are shown together in the display. Often, a group of related functions is so large that all of them can’t be displayed at the same time, so they are broken up into many sub-groups and hence displayed on many pages. This requires you to make numerous button presses and knob turns just to get to the page you want. This scenario is compounded by the fact that certain buttons and knobs have multiple functions and it is easy to get lost or confused in making even the simplest of edits, such as naming a program.

While this not as much of an issue on the A6 due to its large display, this synthesizer literally has thousands of parameters. SysEx editing software running on a personal computer displays most (if not all) of a device’s functions on-screen simultaneously. The frustration level drops dramatically when you can move from page to page with a mouse click, or give a program a name by just typing it on your computer’s keyboard.

SysEx also makes it possible for personal computers and other hardware devices to store program, sample, pattern, sequence or song data to a hard disk, floppy disk or other storage media.

TO SEND AN INDIVIDUAL PROGRAM OR MIX OUT AS A MIDI SYSTEM EXCLUSIVE DUMP:

1. Set your sequencer or data recorder to RECORD mode. Make sure System Exclusive filtering, if any, is OFF.
2. From Program or Mix mode, press **STORE**. Press Soft Button **5**, SYSEX.
3. If you're not already on the Program or Mix you want to send, select it using the **BANK** and **NUMBER** variables on Soft Knobs 1 and 2.
4. Make sure that the **SEND** variable is set to **PROG (MIX)** using Soft Knob 4.
5. A box in the display will read, **HIT STORE TO SEND THIS PROGRAM (MIX) OUT AS A SYSEX DUMP**. Do that.

TO SEND AN ENTIRE PROGRAM OR MIX BANK OUT AS A MIDI SYSTEM EXCLUSIVE DUMP:

Follow the steps above, except in step 4, set the **SEND** variable to **BANK** using Soft Knob 4.

To verify that your sysex file has been received from the A6 properly, you should check the size of the file at its destination. Here are the proper sizes:

One Program: 2350 bytes
One Mix: 1180 bytes
Program Bank: 300800 bytes
Mix Bank: 151040 bytes

If your destination sequencer or computer is not receiving the correct number of bytes, it may be too slow to keep up with the A6's transmission rate. You can slow down the A6's SysEx transmission rate by pressing the **GLOBAL** button, then soft button 7. Next, press and hold soft button 7, then press soft button 8. This takes you to a "secret" page. Use Soft Knob 2 to adjust the SysEx delay. The default value is 7500. Try 15000 or greater if you are having problems.

ABOUT RECEIVING SYSEX DUMPS:

In most cases, simply playing the MIDI sequence with the System Exclusive dump back into the Andromeda will put the SysEx data into the same User or Card bank it was saved from. Preset banks can not be written via System Exclusive dumps: you must burn them into the User bank and use the **COPY** function (explained on previous pages) to burn a new Preset bank.

Before the A6 can receive a SysEx dump, press the **GLOBAL** button, go to the **MIDI** page, and set **SYSEX** (Sysex Receive) to **-ON-**.

The **SYSEX** page of Store mode contains a useful feature under Soft Knob 3 labeled **RCV TO** (Receive To). This gives more flexibility in receiving SysEx Programs and Mixes:

- >**USER** means that the incoming SysEx Program or Mix will go into the User Bank (at whatever Program or Mix number it was originally stored from). This is the default setting.
- >**HERE** means that the incoming SysEx Program or Mix will overwrite the Program or Mix currently shown in the display, regardless of its original bank or number.
- ORIGIN** means that the incoming SysEx Program or Mix will be written to wherever it originally came from. If it came from a Card bank and a card is present, it will write to the Card. Writing directly to a Preset bank from a SysEx file is not allowed.
- CARD** allows you to select a card bank where the Program or Mix should go (assuming you have a properly initialized card plugged into the A6).

Portions of this appendix are abridged versions of material from *Power Sequencing with Master Tracks Pro/Pro 4* and *The Complete Guide to the Alesis HR-16 and MMT-8*, copyright 1990 and 1989 respectively by AMSCO Publications, and are adapted with permission.

MIDI AND THE A6 ANDROMEDA

With the previous description of MIDI basics in mind, let's continue with a few more details concerning the MIDI functions that are present in the A6. A **MIDI Implementation Chart** is provided in **Appendix C** that lists the MIDI functions supported by the A6.

A6 CHANNEL MESSAGES: MULTITIMBRAL SEQUENCING

As we mentioned on page 248, certain instruments are designed such that you can set a voice or group of voices to MIDI Channels other than the Basic Channel the instrument has been set to. This is an important concept to understand when setting up the A6 as a master (transmitting MIDI to other instruments) or as a slave (receiving MIDI from other instruments) in a MIDI music system.

While the Andromeda's Mix Mode and MIDI both have 16 channels, it is possible for the A6 to assign any Mix Channel to any MIDI channel if desired. The Andromeda can send and receive on up to 16 channels at once.

For complete information on multitimbral MIDI operation, see **Chapter 11: Mix Mode**.

SETTING MIDI PARAMETERS IN GLOBAL MODE

The most common MIDI transmission and reception variables are under the GLOBAL button, on the MIDI page (Soft Button 3).

MIDI Page Parameters

| PAGE | PARAMETER | OPTIONS or RANGE | DESCRIPTION |
|------------------------------------|---|---|---|
| MIDI | MIXSEL Mix Select | OFF 1 ... 16 | Determines on which MIDI Channel a Program Change command will select a new Mix. When set to OFF, a MIDI Program Change will select a Program Mix Channel from within a Mix . In this case, MIDI Channel numbers and A6 Mix Channel numbers are matched. For example, if a MIDI Program Change command is received on MIDI Channel 5, Mix Channel 5 responds to the command. |
| | PRG RX Program Change Receive | OFF, ON | Determines whether the A6 will respond to MIDI program changes. |
| | PRG TX Program Change Transmit | OFF, ON | Determines whether the A6 will send MIDI program changes. |
| | BNKSEL Bank Select | | Allows the A6 to work with Bank Select methods used by various controllers, modules and computer software (sequencers, etc.) If you are controlling the A6 from another MIDI instrument, device, or computer, refer to its Owner's Manual to see how it sends MIDI Bank Select messages. |
| | | NORMAL | This setting uses the LSB/MSB combination of CC32/CC0. This method is the one recommended by the MIDI Manufacturers Association. |
| | | CC0 | Controller 0 only selects a bank, CC32 is ignored. |
| | | CC32 | Controller 32 only selects a bank, CC0 is ignored. |
| | CC TX Continuous Controller Transmit | OFF, ON | Allows the A6 to send Continuous Controller messages (mod wheel, pitch wheel, aftertouch, volume, etc.), or for them to be turned off. |
| | CC RX Continuous Controller Receive | OFF, ON | Allows the A6 to receive Continuous Controller messages. |
| SVX RX System Exclusive Receive | OFF, ON | Allows the A6 to receive A6-specific System Exclusive messages. This is to protect patches from becoming unintentionally overwritten. | |

CC MAP Page Parameters

The fourth page of the GLOBAL menu allows you to set which of the 120 MIDI Continuous Controller messages will be transmitted by the Andromeda's controllers.

| PAGE | PARAMETER | OPTIONS or RANGE | DESCRIPTION |
|--------|---|--------------------------------------|---|
| CC MAP | PED CC Pedal | OFF 1 ... 120 | This parameter determines what MIDI Continuous Controller number will be transmitted by a pedal plugged into the CV/PEDAL jack on the rear panel. Note that if you assign the CC Pedal to CC 7 (corresponding to MIDI Volume), the pedal will automatically control the A6's Master Volume without the need to set up a dedicated Mod Route. |
| | FSW CC Footswitch | OFF 1 ... 120 SSHOLD SSTOGL | Sets MIDI Continuous Controller number that will be transmitted by a pedal plugged into the SWITCH jack on the rear panel. When set to SSHOLD, pressing down on the Footswitch will send out a MIDI Start Message, and releasing it will send a MIDI Stop Message. When set to SSTOGL, pressing the Footswitch once will send a MIDI Start Message and pressing it again will send a MIDI Stop Message. With these settings, you can use the Footswitch to control an external sequencer. |
| | RIBUCC Ribbon Value | OFF C20C52 C31C63 | Sets MIDI Continuous Controller number that will be transmitted by the entire Ribbon. Note that this is a two-byte quantity requiring two Continuous Controller numbers. |
| | RIBLCC Ribbon Left | OFF 1 ... 120 | Sets MIDI Continuous Controller number that will be transmitted by the left part of the Ribbon when it is split in the middle. |
| | RIBRCC Ribbon Right | OFF 1 ... 120 | Sets MIDI Continuous Controller number that will be transmitted by the right part of the Ribbon when it is split in the middle. |
| | CTL NUM Continuous Controller Number | CC A-H | Selects which letter (A through H) of the A6's Modulation sources will be mapped to a particular incoming Continuous Controller number. CC A etc. appear as Sources in MOD menus all over the Andromeda, allowing MIDI control of individual synth settings in real time. |
| | CC IN Continuous Controller Input | 0... 127 | Sets what CCnumber will be used to control the Mod source currently selected by CTL NUM above. |

PANEL Page Parameters

This page sets how the top panel controls respond and whether they send and receive MIDI NRPN (Non-Registered Parameter Number) data. MIDI NRPN data can be used to record knob movements and button presses on the A6 to an external sequencer. These moves can be played back to recreate your performance.

Most of the A6 Program and Mix parameters can be controlled by MIDI NRPN data. The exceptions are those functions not related to performance (like setting a Mix Channel’s MIDI channel number) or the Increment and Decrement buttons.

Note that when MIDI NRPN data is controlling the A6, the knob parameter movements will not show up in the A6’s screen unless it is already on the page of that parameter. All button presses will be shown however.

| PAGE | PARAMETER | OPTIONS or RANGE | DESCRIPTION |
|-------|---|-------------------------|--|
| PANEL | PTHRU Knob pass-thru mode | NONE MODLST ALL | When set to ALL, the knob must pass through the current value before the value will change. When set to MODLST, this behavior is applied to the mod lists only. |
| | TXTHIN NRPN data transmission thinning | THIN 1-4 DENSE | This sets the density of the transmitted MIDI NRPN data. Some sequencers have trouble recording very dense MIDI data. If this is the case with your sequencer, set this value to THIN to reduce the amount of MIDI data being sent out the A6’s MIDI port per unit time. A setting of DENSE will cause the most data to be sent per unit time. The 1-4 settings are intermediate density settings. |
| | RXMODE NRPN receive mode | OFF, ON | This determines whether the A6 will respond to incoming MIDI NRPN panel data. |
| | TXMODE NRPN transmit mode | LOCMID MIDI LOCAL | This setting is the same as the keyboard TXMODE, except that it applies to the front panel knobs and switches. |

GLOSSARY

| | |
|-------------------------|--|
| All Notes Off | a command that is transmitted to all devices in a MIDI system that prevents notes from becoming stuck on. |
| Amplitude | the level of a signal, its “intensity” (or lack of it) or the “signal strength”. |
| Channel | one of sixteen separate “paths” that Voice and Mode data can travel on. |
| Channel Messages | data that communicates Voice and Mode messages on a specific, user-selected Channel. |
| Controllers | commands that are used for musical expression (volume, sustain, vibrato, etc.) or remote control of other devices in the MIDI system (reverb depth, bank select, etc.). |
| Default | a parameter’s pre-assigned value or factory setting. |
| Edit, Editing | changes made to a parameter in a Program or Mix, or to a Global function by adjusting its numeric value, turning it on or off and so forth. |
| Exponential | a function that produces a decelerated rate of change (it “slows down”) as it approaches its destination value. |
| Frequency | rate or speed, usually expressed in “cycles-per-second” which indicates how many times a wave or pattern is repeated in one second. Cycles-per-second is most often referred to as “Hertz” – abbreviated “Hz”. |
| Gate | similar to a trigger, a <i>gate</i> not only performs a “go” instruction but also carries with it a duration characteristic. Using the keyboard as an example, a gate signal is active for the time that a key is held down ; a trigger is generated only at the instant the key is first played. Translating our definition of gate to MIDI, the duration of a gate is the time that elapses between the Note On and the Note Off commands. See also “Trigger”. |
| Global | any function that affects the A6 no matter what play mode it’s in: global functions affect all Programs and Mixes. You can think of global functions as “master” functions. |
| LED | Light Emitting Diode: the small panel lights on the A6’s front panel. When an LED next to a knob or button is on, this indicates that the function is active. |
| Linear | a function that produces an even rate of change that, when depicted by a graph, resembles a straight line. |
| Local | any function that is physically present on the A6. |
| Logarithmic | a function that produces an accelerated rate of change (it “speeds up”) as it approaches its destination value. |
| MIDI | “Musical Instrument Digital Interface”; refers to the system of connecting microprocessor-controlled instruments and devices for sharing information. |
| MIDI IN | the port on a device that receives MIDI data |

| | |
|------------------------|--|
| MIDI OUT | the port on a device that transmits the MIDI data generated by the device. |
| MIDI THRU | the port on a device that passes received MIDI data to the next device in the chain. |
| Mix | a performance mode where two or more Programs are played at the same time. Mix mode is where you make settings for splits and layers plus numerous combinations of Programs, and keyboard/MIDI control. |
| Mode | a particular state that an instrument or device is currently in; in MIDI, “mode” refers to the unit’s receive state that determines 1. how MIDI messages are received, and 2. how voices will be assigned to handle MIDI notes. |
| Note Off | a general term that indicates that a pressed key on the local keyboard has been let go, a MIDI Note Off message has been received, or the end of the Gate Time from the Sequencer or Arpeggiator has been reached. |
| Note On | a general term that indicates that a key has been pressed on the A6’s keyboard, a MIDI Note On message has been received, or notes are being played from the A6’s Arpeggiator or Sequencer. |
| Omni Off | a receive function that instructs the device to respond to commands on a specific, user-selected Channel. |
| Omni On | a receive function that instructs the device to respond to commands on any Channel. |
| Page | a group of related parameters on the display. |
| Parameter | a basic element of an A6 function. |
| Program | the settings that cause the voices to produce a particular sound. |
| Program Change | a command that instructs the receiving instrument to recall a specific sound program from memory. |
| RAM | “Random Access Memory”: the physical circuit chips inside the A6 where data is stored. RAM is a type of memory that you can change and is also referred to as user memory. |
| ROM | “Read Only Memory”: the physical circuit chips inside the A6 where data is stored. ROM is a type of memory that is permanent and is also referred to as preset memory. |
| SysEx | “System Exclusive”; data that is unique to a particular MIDI device. |
| System Messages | data that is transmitted to all devices in a MIDI system; this data is not Channel-specific. |
| Timing Clock | a data stream that synchronizes MIDI devices, such as a sequencer or drum machine. |
| Trigger | a “go” signal that is routed from a source (such as the keyboard) to a modulation function. A trigger has no significant duration as it is simply an electronic pulse. Translating our definition of trigger to MIDI, a trigger is the equivalent of a Note On command. See also “Gate”. |
| Voice | the most basic component of a synthesizer that produces sound. A voice is all of the hardware and software that is necessary to produce one note of sound. |

MOD SOURCES

TABLE OF SOFTWARE MODULATION SOURCES

| DISPLAYED AS | MEANING |
|-------------------------|---|
| 1. OFFSET ONLY | Fine adjustment amount by the onscreen fader only: no other modulation is present. |
| 2. VOX KEY NUMBER | The key or MIDI Note Number for the voice being played. |
| 3. VOX KEY ON VEL | The key or MIDI Note Velocity amount for the voice being played. |
| 4. VOX KEY OFF VEL | The key or MIDI Note Release Velocity amount for the voice being played. |
| 5. KEY AFTERTOUCH | The amount of Aftertouch from the A6's keyboard. |
| 6. MIDI AFTERTOUCH | The amount of Aftertouch from MIDI In. |
| 7. MOD WHEEL | The Modulation Wheel level. |
| 8. PITCH WHEEL | The Pitch Wheel level. |
| 9. RIBBON VALUE | The Ribbon Controller amount from anywhere on its entire length. |
| 10. RIBBON LEFT | The Ribbon Controller amount from its left side only. |
| 11. RIBBON RIGHT | The Ribbon Controller amount from its right side only. |
| 12. LFO 1 | The current level of LFO 1. |
| 13. LFO 2 | The current level of LFO 2. |
| 14. LFO 3 | The current level of LFO 3. |
| 15. SAMPLE AND HOLD LVL | The current level of the Sample and Hold generator. |
| 16. ENVELOPE 1 | The current level of Envelope 1. |
| 17. ENVELOPE 2 | The current level of Envelope 2. |
| 18. ENVELOPE 3 | The current level of Envelope 3. |
| 19. TRACK GEN STEP | The quantized output of the Tracking Generator (the QUANT parameter must be on). |
| 20. TRACK GEN LEVEL | The smoothed output level of the Tracking Generator. |
| 21. SEQ LEVEL A | The output of the Sequencer's Note level. |
| 22. SEQ LEVEL B | The output of the Sequencer's Velocity level. |
| 23. SEQ LEVEL C | The output of the Sequencer's Gate level. |
| 24. ARP KEY NUMBER | The Arpeggiator's generated note values as set by its LENGTH, OCTAVE, CENTER and TYPE parameters. |
| 25. ARP VELOCITY | The velocities of the Arpeggiator's generated notes. |
| 26. PORTA LEVEL | A bipolar source that represents the current Portamento Time, direction and size. It always settles to zero. If you play a legato note below the first played note, a falling level will occur. If you play a note above the first played |

Appendix B: Table of Software Modulation Sources

| | |
|---------------------|--|
| | note, a rising level will occur. The level of this source depends on the difference between the notes played. |
| 27. PORTA RAW LEVEL | A bipolar rising or falling source that represents the direction of Portamento. If you play a legato note below the first played note, a slow rise to full output will occur, starting from zero. If you play above the first played note, a slow descent from full output to zero will occur. Playing the same note twice will not cause any output change. |
| 28. VOICE RANDOM | A digital random value generator that is independent per Voice (it has a different output level per Voice). |
| 29. SUSTAIN PEDAL | The output state of an on/off sustain pedal. This can be used as a level or trigger. |
| 30. FOOT SWITCH | The output state of an on/off foot switch. This can be used as a level or trigger. |
| 31. CONTROL PEDAL | The output level of continuous control pedal, e.g. volume pedal. |
| 32. MIDI VOLUME | The current MIDI volume level. |
| 33. PGM KEY NUMBER | The value of the last note played. |
| 34. KEY TRIG RATE | A mod source that reacts to the number of notes played over time. A flurry of notes will produce a high-level output. A very slowly played set of notes will produce a low-level output. Useful for changing a Mod level depending on your style of playing. |
| 35. PGM KEY ON VEL | The key-on velocity level of the last note played. |
| 36. PGM KEY OFF VEL | The key-off velocity level of the last note played. |
| 37. PGM KEY DOWN | |
| 38. PGM NUMKEYS ON | A level proportional to the number of keys held. The level will be zero if no notes are played and rises as more notes are played, with a maximum level at sixteen. Useful for scaling volume down in proportion to the number of notes held. |
| 39. TEMPO | A level proportional to the position of the Master Clock TEMPO knob. |
| 40. MASTER CLOCK | A trigger that occurs every quarter note at a tempo determined by the Master Clock. |
| 41. MIDI CLOCK | A trigger that occurs every quarter note at a tempo determined by the incoming MIDI Clock. |
| 42. MIDI START | A trigger that occurs when a MIDI Start message is received from an external device. |
| 43. MIDI STOP | A trigger that occurs when a MIDI Stop message is received from an external device. |
| 44. MIDI FIRST CLK | |
| 45. MIDI START/CONT | A trigger that occurs when a MIDI Continue message is received from an external device. |
| 46. SAMPHOLD CLOCK | A trigger that occurs upon each cycle of the Sample and Hold's Clock. |

Appendix B: Table of Software Modulation Sources

| | |
|---------------------|---|
| 47. PGM KEY TRIGGER | A trigger that occurs when any note is played. This is commonly used for triggering the Sequencer and Arpeggiator. |
| 48. EXT TRIGGER 1 | A trigger that occurs when the audio input level at the Voice 15 External Audio Input jack rises above a set threshold. A “triggered wah” effect can be obtained if Envelope 2 is used to sweep the Filter(s) and this trigger is used to trigger Envelope 2. |
| 49. EXT TRIGGER 2 | A trigger that occurs when the audio input level at the Voice 16 External Audio Input jack rises above a set threshold. |
| 50. GLOBAL RANDOM | A “master” digital random value generator that is common across all voices. Use this if you want each voice to be modulated exactly the same, as opposed to the Voice Random, in which the value is different for every voice. |
| 51. ENV 1 ATTACK | A trigger that occurs at the beginning of the Attack stage of Envelope 1. |
| 52. ENV 1 DECAY 1 | A trigger that occurs at the beginning of the Decay 1 stage of Envelope 1. |
| 53. ENV 1 DECAY 2 | A trigger that occurs at the beginning of the Decay 2 stage of Envelope 1. |
| 54. ENV 1 SUSTAIN | A trigger that occurs at the beginning of the Sustain level of Envelope 1. |
| 55. ENV 1 RELEASE 1 | A trigger that occurs at the beginning of the Release 1 stage of Envelope 1. |
| 56. ENV 1 RELEASE 2 | A trigger that occurs at the beginning of the Release 2 stage of Envelope 1. |
| 57. ENV 1 END | A trigger that occurs at the end of the Release 2 stage of Envelope 1. This is useful for cascading and looping envelopes. |
| 58. ENV 2 ATTACK | A trigger that occurs at the beginning of the Attack stage of Envelope 2. |
| 59. ENV 2 DECAY 1 | A trigger that occurs at the beginning of the Decay 1 stage of Envelope 2. |
| 60. ENV 2 DECAY 2 | A trigger that occurs at the beginning of the Decay 2 stage of Envelope 2. |
| 61. ENV 2 SUSTAIN | A trigger that occurs at the beginning of the Sustain level of Envelope 2. |
| 62. ENV 2 RELEASE 1 | A trigger that occurs at the beginning of the Release 1 stage of Envelope 2. |
| 63. ENV 2 RELEASE 2 | A trigger that occurs at the beginning of the Release 2 stage of Envelope 2. |
| 64. ENV 2 END | A trigger that occurs at the end of the Release 2 stage of Envelope 2. This is useful for cascading and looping envelopes. |
| 65. ENV 3 ATTACK | A trigger that occurs at the beginning of the Attack stage of Envelope 3. |
| 66. ENV 3 DECAY 1 | A trigger that occurs at the beginning of the Decay 1 stage |

Appendix B: Table of Software Modulation Sources

| | |
|---------------------|--|
| | of Envelope 3. |
| 67. ENV 3 DECAY 2 | A trigger that occurs at the beginning of the Decay 2 stage of Envelope 3. |
| 68. ENV 3 SUSTAIN | A trigger that occurs at the beginning of the Sustain level of Envelope 3. |
| 69. ENV 3 RELEASE 1 | A trigger that occurs at the beginning of the Release 1 stage of Envelope 3. |
| 70. ENV 3 RELEASE 2 | A trigger that occurs at the beginning of the Release 2 stage of Envelope 3. |
| 71. ENV 3 END | A trigger that occurs at the end of the Release 2 stage of Envelope 3. This is useful for cascading and looping envelopes. |
| 72. MIDI CC A | A MIDI Continuous Controller, selected for A-H in GLOBAL mode, on the CC MAP page. Any of the 128 different MIDI Controller numbers may be selected for any of the eight letters and used to modulate the A6 via MIDI. See page 257. |
| 73. MIDI CC B | |
| 74. MIDI CC C | |
| 75. MIDI CC D | |
| 76. MIDI CC E | |
| 77. MIDI CC F | |
| 78. MIDI CC G | |
| 79. MIDI CC H | |

TROUBLESHOOTING

THE AUTO-TUNE DISPLAY

The basics of **AUTO TUNE** were covered in Chapter 1: pressing the button twice initiates a software routine that will automatically tune every circuit in the Andromeda that is subject to thermal drift. Ideally, you won't have to worry about the details of Auto Tune... simply press it twice every time you turn on the unit.

But if something still sounds out of tune on several different Programs after performing a complete Auto Tune, the Auto Tune display may be able to show you what's wrong so you can temporarily overcome the problem by turning off a malfunctioning voice.

TIPS AND TRICKS ABOUT TUNING

If **AUTO TUNE** was last pressed when the A6 was warmed up, in most cases the unit won't fall out of tune from a short power on-off. Even if it does drift a bit, it will likely drift back into tune when the temperature returns to the old level, without having to press **AUTO TUNE** again.

If you don't have enough time to wait through an entire Auto Tune, you may be able to get most of the benefits of a complete Auto Tune routine by tuning the oscillators only. Press soft button **4** (**OSCFRQ**) twice. (See below.)

Background Tuning constantly monitors unused oscillators and tunes them. It must wait for a voice to become inactive to tune it. Once the A6's temperature stabilizes, you can turn this off if you wish and let **Temperature Tuning** take care of tuning. Temperature Tuning can tune voices even when they are playing by monitoring the temperature of the hardware and adjusting the tuning accordingly.

If you plan on making a Program or Mix that will be used on a different Andromeda, it's particularly important to make sure the unit is in tune before you make final adjustments and store the Program; otherwise it may sound very different on another unit.

Auto Tune Parameters

The Auto Tune display is different from other displays in that soft buttons **2 - 6** pull up the page with the first press, and start the specific tuning process with the second press.

| SOFT KNOB → | 1 | 2 | 3 | 4 | 5 | 6 | 7 | 8 |
|-------------|--------|--------|--------|---|---|---|-------|------|
| ↓ PAGE TAB | | | | | | | | |
| TUNE | MASTER | BKTUNE | TMFTUN | | | | VOICE | BAND |
| AUTO | | | | | | | VOICE | BAND |
| VCACAL | | | | | | | VOICE | BAND |
| OSCFRQ | | | | | | | VOICE | BAND |
| OSCPW | | | | | | | VOICE | BAND |
| FILFRQ | | | | | | | VOICE | BAND |

AUTO TUNE Parameters

| PAGE | PARAMETER | OPTIONS or RANGE | DESCRIPTION |
|--------|--|----------------------------|--|
| TUNE | MASTER | 354.35 Hz ... 546.42 Hz | Sets the basic tuning reference of the Andromeda for A4 (the A above middle C). The default is 440.00 Hz, which is the modern concert reference. You can set it to A=440 by pressing the INC/DEC keys simultaneously. |
| | BKTUNE | ON/OFF | When ON, the Andromeda will constantly tune unused oscillators in the background. |
| | TMPTUN | ON/OFF | When ON, the Andromeda will constantly monitor its temperature and adjust the oscillators to compensate for changes. |
| AUTO | VOICE | 1-16 | Selects which of the A6's sixteen voices is currently shown in the TUNE display. |
| | BAND | 1-16 | Selects which oscillator tuning band is shown in the top line of the display. |
| VCACAL | Press twice to initiate a calibration of each VCA's base levels. | | |
| OSCFRO | Press twice to tune the oscillators only. | | |
| OSC-PW | Press twice to tune the pulse width of the oscillators only. | | |
| FILFRO | Press twice to tune the filter frequencies only. | | |

HOW TO USE THE TUNE DISPLAY

Pressing the **AUTO TUNE** button will take you to the **AUTO** page. This displays a summary of the A6's tune status. The top row shows the voice number. The middle row shows the tune status of each voice's VCAs. The bottom row shows the tune status of the filters and oscillators. A "T" under the voice means it was tuned properly. A blank space means the voice was not tuned since the last powerup.

In the other Auto Tune pages except **TUNE** page, the display gives more tuning details. Usually, this will be of no concern, but in case there's some problem, you can track it down using this display. There are a **lot** of things to tune in an analog synthesizer. Each of the Andromeda's 16 voices has two oscillators which need to be tuned over 17 different frequency bands. In addition, the pulsewidth, filter frequencies, and the VCAs need to be calibrated.

With so many different variables, there's not room to monitor them on a single screen. So, you need to scroll through the displays using the **VOICE** and **BAND** controls to see them all. Here's an example of what a screen may look like:

| | | | | | | | | |
|----|--------|--------|--------|--------|--------|--------|-------|------|
| 1: | TUNEOK | TUNEOK | TUNEOK | -OSC1- | TUNEOK | TUNEOK | | |
| 2: | TUNEOK | TUNEOK | TUNEOK | NOTUNE | TUNEOK | TUNEOK | | |
| 3: | TUNEOK | TUNEOK | | | TUNEOK | TUNEOK | | |
| 4: | TUNEOK | TUNEOK | | | TUNEOK | TUNEOK | | |
| 5: | TUNEOK | TUNEOK | | | TUNEOK | TOOHI | | |
| 6: | TUNEOK | TUNEOK | | | | | | |
| | OSC1 | OSC2 | VCA | OSC-PW | FILT1 | FILT2 | 12 | 1 |
| | | | | | | | VOICE | BAND |

The **TUNEOK** in the Oscillator columns means that the first six bands (which represent the lower octaves of the range) of this voice (12, in this case) went through an Auto Tune process and were OK. The **NOTUNE** in the Oscillator Pulse Width column shows that the Pulse Width has **not** gone through an Auto Tune process. The **TOOHI** in the 5th band of Filter 2 shows that Auto Tune was not able to bring this band into range. (Unless you're using Filter 2 as an oscillator, and playing it in the highest octaves, this won't be noticable.)

It isn't unusual for the very highest bands of the oscillators to be out-of-range after an Auto Tune procedure, especially if the unit is cold. Try again after the unit has warmed up. Even when the tuning is not exact enough to "win" an "OK" from the computer, it may still sound OK. But if a voice won't show "OK" in its lower bands, after several attempts, the unit may require servicing.

To CHECK FOR AN OUT-OF-TUNE VOICE:

1. Press **AUTO TUNE** once.
2. Turn the **VOICE** knob (soft knob **7**) to show Voice 1 in the display.
3. Note any voice bands that do **NOT** say **TUNEOK**.
4. Turn the **BAND** knob (soft knob **8**) to show band 7 at the top of the display.
5. Again, note any voices that say **TOOHI** or **TOOLO**.
6. Turn the **BAND** knob (soft knob **8**) to show band 13 at the top of the display.
7. Again, note any voices that say **TOOHI** or **TOOLO**.
8. Turn the **VOICE** knob (soft knob **7**) to show the next voice in the display, and repeat steps 3–8 until all bands of all sixteen voices are checked.

If a band isn't in tune, let the instrument warm up for a while, and perform a complete Auto Tune again before proceeding to the next step.

To TURN OFF AN UNTUNED VOICE:

If the Auto Tune procedure doesn't fix a voice and it's noticeably out of tune, there may be a physical problem with the instrument. In this case, Auto Tune will automatically turn the voice off. All other voices may be in tune... it's only when this untuned voice is called on that you could hear a pitch problem. But the Andromeda does allow you to turn off individual voices using its Voice Monitor feature. You'll lose a voice of polyphony, but the voices that remain will be in tune.

After you know which voice can't be tuned using the procedure above:

1. Press **GLOBAL**.
2. Press **VOXMON** (soft button **8**).
3. To turn a voice off, press any of the **SELECT** buttons (**1/9** through **8/16**). Press **SHIFT** to access voices 9–16.

Another way to check quickly for "problem" voices is to watch the **VOXMON** display while playing. An "X" appears above the voice number as it's played. When you hear the voice that's out of tune, note which voice has an "X" above it.

UPGRADING THE OPERATING SYSTEM

While the Andromeda's sound-generating electronics are all analog, they are controlled by a digital microprocessor with software, just like a computer. This software resides in flash memory, and is upgradeable via MIDI. Over the course of time, Alesis may make improvements to the operating system and make a new operating system available to Andromeda owners. Check www.alesis.com for information about the latest version of A6 software. Upgrading the software will **not** affect, in most cases, your Programs and Mixes, but check the documentation to be sure, and make a backup copy (to card or a SysEx file) of your User banks before proceeding.

TO DISPLAY THE VERSION OF SOFTWARE IN YOUR A6:

Press **GLOBAL**, then soft button **1**. The OS version will be displayed at the top of the screen.

There are actually two parts of the A6 code: the OS and the bootloader. The bootloader is the basic code that allows you to upgrade the operating system itself. It will probably never need upgrading. The OS is where the majority of the code resides. To find out your bootloader version number, turn on the A6 while holding down soft button **6**. The display will show the version numbers for the bootloader and the OS.

Tip: Before upgrading to a new version of software, connect the MIDI OUT of the A6 to the MIDI IN of a sequencer, set it to record a SysEx dump, and press **STORE** from this page. This will give you a backup copy of the old operating system in case there is a problem with transmitting the new one.

TO UPGRADE THE SYSTEM SOFTWARE OF YOUR A6:

1. Obtain the new operating system (OS) from the Alesis website (www.alesis.com). *The file will need to be decompressed via a utility such as Unzip before using. Make sure your utility does not alter the files in any way, such as stripping line-feeds, or converting files to text. The decompressed files will have the extensions ".mid" for MIDI files and ".syx" for System Exclusive files.*
2. Start your sequencer program or SysEx transfer software (like Alesis Freeloader), decide which file format to use, and load the file(s) into your program. *You may decide to use either the SysEx files or MIDI files, whichever your software is able to transmit. The multiple-file format (files prefixed by an "M") is for programs that can't handle large single files. If you choose to use the multiple files, you may transmit them to the A6 in any order and the A6 will sort them out. In some sequencers, you may need to open a blank sequence before opening a SysEx file.*
3. Make sure you disable any "Chase Events", "Send MIDI Clock" and "Transmit MMC/MTC" functions in your sequencing software. You may also need to increase the buffer size or adjust the transmit speed of your sequencing software.
4. Connect the computer's MIDI OUT to the MIDI IN of the Andromeda.
5. Turn on the Andromeda while holding down soft button **7**. A screen will appear showing the current software version number. It will also display, "IF RAM CARD IS IN PLEASE REMOVE IT AND PRESS ANY SWITCH." Do that.

6. The display will now say, "Press STORE to upgrade OS—any other switch to exit." Press **STORE**.
7. Now press **PLAY** on your sequencer. It is normal for many sequencers to "freeze" the display while sending a SysEx message, so it may seem that nothing is happening, but wait several minutes for the transmission to complete. You should see the count of blocks increment on the A6's screen, and the progress bar will slowly fill in. This takes several minutes for a complete operating system.
8. Eventually, after all blocks have been received, the screen will display a message "GOOD DOWNLOAD—PRESS STORE TO BURN FLASH". Press **STORE** and the messages "Erasing Block XX" and "Writing Block XX" will appear. Do not interrupt this part of the process for any reason, or your flash memory could get corrupted and your A6 might require factory service!
9. At the end of the process, the Andromeda will automatically restart, return the unit to Program mode, and re-tune.

Note that updating the OS does not overwrite your User or Preset Programs or Mixes. However, it is a good idea to save your work before updating your OS.

If your transmission was not successful, a "BAD CHECKSUM" message will appear on the screen. DON'T PANIC. You can always repeat the procedure or leave your current OS untouched. A new OS file is not stored permanently until the flash memory is burned. Try adjusting the parameters in your computer software (some of which are mentioned above) until you get a good download.

POWER UP MODES

We have already mentioned a few power up modes that are entered by holding down a soft button while powering up the A6. Here is a summary of all of them:

| POWER UP WHILE HOLDING | FUNCTION |
|------------------------|--|
| Soft Button 1 | Forces A6 to load default Program and Mix. This is useful if the A6 has received corrupted data, causing it to hang. |
| Soft Button 2 | Enters front panel debug mode. |
| Soft Button 3 | Initializes all user RAM. This is also known as a Hard Reset. Warning, this will erase all User Programs and Mixes, replacing them with the factory default User Programs and Mixes! |
| Soft Button 4 | Initializes all Global parameters, including tuning tables. |
| Soft Button 5 | Re-calibrates Mod Wheel and Ribbon Controller. |
| Soft Button 6 | Sends software OS out as MIDI Sys Ex dump. |
| Soft Button 7 | Enables the A6 to receive software Sys Ex dump (OS or bootloader). |
| Soft Button 8 | Replaces the factory default User Programs and Mixes with the User Bank Programs and Mixes. The next time a RAM initialization is done (Soft Button 3), these banks will be used to initialize the User Banks. |

TROUBLESHOOTING CHART

If you experience problems while operating your Andromeda A6, please use the following table to check for possible causes and solutions *before* contacting Alesis customer service for assistance. Some of them may seem rather obvious, but you'd be amazed at how easy it can be to overlook the basics.

| SYMPTOM | CAUSE | SOLUTION |
|---|---|--|
| The display does not light up when the ON/OFF switch is turned on. | No power. | Check that the power cable is plugged in properly. |
| No sound. | Volume is turned down. | Raise the VOLUME pot, LEVEL pot or volume pedal if one is being used. |
| | MIDI Volume on master controller is set to 0. | Check MIDI Volume level on master MIDI device. |
| | Output has been switched to AUX or OFF. | Press OUTPUT switch on right side until MAIN LED is lit. |
| | Set to MIDI (local keyboard off) mode in the Global menu. | Set to LOCAL or LOCMID on the GLOBAL/MIDI page, MODE parameter. |
| | Voices are turned off. | Press GLOBAL , go to the VOXMON page, and turn the voices back on using the Mix Channel Select keys. |
| Voices are out of tune with each other. | Temperature changes after power-up affecting analog circuits. | Press AUTO TUNE twice. Then, enable Background Tuning and Temperature Tuning (see "The Auto Tune Display" above). |
| Unit responding strangely on all programs. | Software glitch in memory. | Reinitialize Global parameters by turning unit on while holding Soft Button 4 . |
| Unit not responding to MIDI input. | Wrong MIDI channel being received. | Set MIDI channel using GLOBAL/KEYBD page. Or, if a Mix , make sure the Channel is enabled (green LED on) and is set to the right MIDI channel on the MIX/PROG page. |
| | Reception of MIDI Program Change, CC, SysEx, or other types of messages turned off. | Turn them on using the GLOBAL/MIDI and CC MAP pages. |
| | Set to LOCAL mode. | Set to MIDI or LOCMID on the GLOBAL/MIDI page, MODE parameter. |

| SYMPTOM | CAUSE | SOLUTION |
|---|--|---|
| Unit "hangs" (won't respond to top panel) whenever a particular Program, Mix, or Bank is accessed | Corrupted data in memory. | Replace an individual Program or Mix by a SysEx dump or the COPY feature in STORE mode. If the entire User bank is corrupted, turn the unit on while pressing soft button 3. This erases the contents of the User bank and reinitializes the Global parameters as well. If a Preset bank is corrupted, press STORE and use the COPY feature to overwrite the entire bank with a non-corrupted bank. Banks are also available on the Alesis web site. |
| Mod wheel doesn't work as expected. | Mod wheel wasn't in lowest position when the unit was reinitialized. | Reinitialize the unit (turn on while holding down soft button 4) with the mod wheel in its full down position. |

CLEANING AND MAINTENANCE

While your Andromeda A6 should not need much attention, here are some tips for preventive maintenance:

- Disconnect the AC power Adapter, then use a damp cloth to clean the A6's metal and plastic surfaces. For heavy dirt, use a non-abrasive household cleaner such as Formula 409® or Fantastik®. **DO NOT SPRAY THE CLEANER DIRECTLY ONTO THE FRONT OR BACK OF THE UNIT AS IT MAY CONTAMINATE THE INTERNAL CARD SLOT CONTACTS, THE DISPLAY OR THE FRONT PANEL BUTTONS!** Spray onto a cloth, then use the cloth to clean the unit.
- Periodically check the power adapter for signs of fraying or damage.
- Unplug the Andromeda's AC power adapter when not in use for extended periods of time.
- Place a dust cover over the unit when it is not in use.
- Vacuum around the RAM card slot to keep dust from falling into it. **DO NOT SPRAY ANY KIND OF CLEANER OR LUBRICANT** into the card slot.
- The one place where contact cleaner may be useful is on the three 1/4" back panel jacks and cables. Periodically disconnect the A6 from AC power and all cables, and clean the 1/4" cable ends with rubbing alcohol or electronic contact cleaner, then work the plug into the jack repeatedly. **DO NOT SPRAY CONTACT CLEANER DIRECTLY INTO THE JACKS.** It's better to use a damp plug to clean the jacks, or use a cotton or foam swab (but be careful not to get cotton or foam stuck in the unit). While Alesis does not endorse the use of any specific product, certain contact enhancers (such as Cramolin™) may be used to keep the connections from corroding in the future.

SPECIFICATIONS

MIDI IMPLEMENTATION CHART

| Function | | Transmitted | Recognized | Remarks |
|--|---|-------------------------------------|-----------------------------------|-------------------------------|
| Basic Channel | Default Changed | 1 - 16 1 - 16 each | 1 - 16 1 - 16 each | Memorized |
| Mode | Default Messages Altered | Mode 3 X * * * * * | Mode 3 X | |
| Note Number | True Voice | 33-96 * * * * * | 33-96 33-96 | |
| Velocity | Note On Note Off | O O | O X | |
| After Touch | Keys Ch's | X O | X O | |
| Pitch Bender | | X | O | |
| Control Change | 0 - 120 | O | O | Transmitted from CV pedals |
| Prog Change | True # | O ¹ 0 - 127 * * * * * | O ¹ 0 - 127 0 - 127 | |
| System Exclusive | | O | O | |
| System Common | Song Position Song Select Tune Request | X X X | X X O | |
| System Realtime | Clock Commands | O O | O O | |
| Aux Messages | Local On/Off All Notes Off Active Sense System Reset | X X X X | X O X O | CC #122 CC #123 CC #121 |
| Notes ¹ O, X is selectable | | | | |

Mode 1: OMNI ON, POLY

Mode 3: OMNI OFF, POLY

O : Yes

Mode 2: OMNI ON, MONO

Mode 4: OMNI OFF, MONO

X : No

For a more information on the A6's MIDI SysEx implementation, see the Alesis website.

SPECIFICATIONS

Polyphony

16-voice, 16-channel multitimbral

Synthesis Method

True analog subtractive

Oscillators

2 oscillators (with sub-oscillation) per voice, 5 waveforms available (sine, triangle, square, up saw, down saw)

Filters

2-pole multimode resonating filter per voice, 4-pole lowpass resonating filter per voice

Program Memory

256 preset and 128 user-defined

Mix Memory

128 user-defined

Audio Outputs

16 mono outputs, one for each of 16 voices (eight 1/4" TRS jacks)
Stereo main outputs (two 1/4" jacks)
2 mono aux outputs (two 1/4" jacks)
Stereo headphone output (1/4" TRS jack)

Audio Inputs

Two 1/4" jacks

External Audio Filter Inputs

Three 1/4" jacks – one each for Voices 1-16, Voice 15, and Voice 16

Pedal Jacks

Pedal/CV, Switch and Sustain – each with dedicated 1/4" jack

MIDI Connections

MIDI In, Out, Thru

Memory Card Slot

PCMCIA-format, SRAM (256K to 2MB)

Power

100-230 VAC, 50/60 Hz 30W

Dimensions (WxHxD)

40.1" x 4.8" x 16.1"

1019mm x 122mm x 409mm

Weight

47lbs.

21 kg

WARRANTY

This product is warranted by Alesis to the original purchaser against defects in material and workmanship for a period of 1 year for parts and labor from the date of purchase. Please retain a copy of your dated sales receipt for proof of warranty status should repairs be necessary.

REFER ALL SERVICING TO ALESIS



We believe that your Andromeda A6 should provide years of trouble-free use. However, should problems occur, **DO NOT** attempt to service the unit yourself. Service on this product should be performed only by qualified technicians. **THERE ARE NO USER-SERVICEABLE PARTS INSIDE.**

OBTAINING REPAIR SERVICE

Before contacting Alesis, check over all your connections, and make sure you've read the manual. Your Alesis dealer may be able to offer further assistance.

Customers in the USA:

If the problem persists, copy down the serial number of your Andromeda, obtain the Alesis phone number from the website, and call the Technical Support Department. Talk the problem over with one of our technicians; if necessary, you will be given a return authorization (RA) number and instructions on how to return the unit to Alesis or the nearest authorized service center. All units must be shipped prepaid and C.O.D. shipments will not be accepted.

You must indicate the RA number on the shipping label or the shipment will not be accepted. If you do not have the original packing, ship the A6 in a sturdy carton with shock-absorbing materials such as foam or "bubble-pack" surrounding the unit. Shipping damage caused by inadequate packing is not covered by the Alesis warranty. Ship the unit with insurance via a carrier that provides a tracking system.

Tape a note to the top of the unit describing the problem, include your name and a phone number where Alesis can contact you if necessary, as well as instructions on where you want the product returned. Alesis will pay for standard one-way shipping back to you on any repair covered under the terms of this warranty.

Field repairs are not authorized during the warranty period, and repair attempts by unqualified personnel may invalidate the warranty.

Customers outside the USA:

Contact your local Alesis dealer for warranty assistance. Do not return products to the factory unless you have been given specific instructions to do so. Your warranty is valid only in the country of purchase.

Internet Address:

Important information is available on our web site: <http://www.alesis.com>
Check the website for online warranty registration.

E-mail may be addressed to: support@alesis.com

-
- AFTCH 50
 - Aftertouch 42,50,54
 - Amplitude 19
 - Analog Distortion 204
 - Arpeggiator 79-80,100
 - Audio
 - Connections 22
 - External In 186
 - Mixing 99
 - Auto Tune 26,53,265-267
 - Aux Outputs 190
 - Band Pass Filter 118
 - Bootloader 268
 - Bypass 189
 - Card 45,94,101
 - Cents 105
 - Chord Button 58
 - Chorus 222-223
 - Cleaning 272
 - Clock 69-71
 - CNTL 42
 - Controllers 42,100
 - Continuous 51, 249,257
 - Contrast 36
 - Control Routes 198-199
 - Compare Button 37
 - Copy 44-45
 - Decrement Arrow 36
 - Delay Effects 220-221
 - Detune 55-57
 - Digital Effects 204-206,211-242
 - Architecture 211
 - Copy 246
 - Delays 220-221
 - Mix Mode 246
 - Pitch Effects 222-226
 - Reverbs 215-220
 - DIR 44
 - Display 32,101
 - Functions 37
 - Distortion Effect 204
 - Dynamics 158
 - Effects 101,203
 - Engine Optimizer 181-182
 - Envelopes 84,134-170
 - Attack 134,137
 - Decay 134,137
 - Dynamics 158
 - ENV 1 AMOUNT 107
 - Level 141
 - Loop 160-163
 - Mod 164
 - Modes 144
 - MODTRG 153
 - RELMOD 159
 - Shape 139
 - Time 137
 - Trig 142
 - Exponential 20
 - External Inputs 186
 - External Triggers 262
 - Filters 98,116-130
 - Cutoff 116
 - Band Pass 117
 - Bypass 189
 - Feedback 186
 - High Pass 117
 - Low Pass 117
 - Notch 117
 - Resonance 120
 - Routing 187
 - Fine Tune 105
 - Flash Memory 97
 - FM 109-110
 - Foot Switch 22,51,68
 - Frequency 19
 - FSWMOD 51
 - Fundamental 83
 - Gate 19
 - Global 20, 49
 - Button 37
 - Functions 31
 - Global Random 262
 - Hard Reset 269
 - Hard Sync 115
 - Hold 67
 - Increment Arrow 36
 - Initializing Memory 45, 269
 - KBD 40, 55
 - KEYBD 49,56
 - Key Track 121,129
 - Knob MIDI 258
 - LED 20
 - Lezlie 223
 - LFO 87, 171-178
 - Mod 176
 - Sync 176
 - TRIG 175
 - Wave 172
 - Layer 47
 - Loading Software 268
 - Local 40
 - Lock Display 36, 37
 - Logarithmic 20
 - LOOP 160-163
 - Lowest Voice Assign 57
 - Main Outputs 190
 - Manual Button 37
 - Master
 - Controls 101
 - Volume 28,99,101
 - Tune 52,101
 - Transpose 101
 - Memory 97
 - Functions 35
 - MIDI 247-258
 - CC Parameters 256-257
 - Channels 243-244
 - Connections 23-25
 - Continuous Controllers 257
 - Controllers 250
 - Implementation Chart 273
 - NRPN 258
 - Patchbay 25
 - Slave 24
 - System Exclusive Dump 253-254
 - Mix 18
 - Button 37
 - Channels 243
 - Copy 245
 - Effects 246
 - Functions 30
 - Layer 47
 - MIDI 244
 - Mode 94,243-246
 - Name 46
 - Parameters 39
 - Selecting 38
 - Select Buttons 36
 - Solo 245
 - Splits 48
 - Mod Assign 67
 - MODCHN 70
 - Modes of Operation 34
 - Modulation 131-133,191-202
 - Display 193
 - List of Sources 261-264
 - Matrix 192
 - Signal Flow 200
 - MODVOX 70
 - Mono 56,57
 - Name 46
 - Noise 185
 - Noise/External 185
 - Notch Filter 118
 - Note Range 54
 - NRPN 258
 - NZEXT 111
 - Offset 19
 - OS Software 268
 - Oscillators 103-115
 - ENV 1 Amount 107
 - FM 109-110
 - Modulation 107,111-112
 - NZEXT 111
 - OSC 2 FM 109
 - PWM 113
 - Sync 115
 - Tune 105
 - Wave 106
 - Pan 190
-

- PANEL 258
- Parameter 18
- PCMCIA 45,94,101
- Pedal 22,51,68
- PEDMOD 51
- Pitch Assign 66
- Pitch Effects 222-223
- Plate Reverb 215
- Pre Filter Mix 99,183-184
- Poly/Mono 55,56
- Portamento 59
 - Curve 60,62-63
 - Enable 60
 - Legato 61
 - Mod 59,64
 - Parameters 60
 - Speed 60
 - STMODE 64
 - Time 59,60
- Post Filter Mix 99,189
- Power 102
- Power Up Modes 269
- Process 179
- Progressor 77
- Program 18. 27
 - Button 37
 - Functions 30
 - Mode 93
 - Name 46
 - Parameters 39, 41
 - Selecting 38
- PWM 113
- RAM 18
 - Card 45,94,101
- Rear Panel 101
- Repair 275
- Resonance 120
- Reverb 208-210,215
 - Damping 218
 - Decay 216
 - Density 217
 - Depth 219
 - Early Reflections 218
 - Gate 220
 - Pre-Delay 217
 - Swirl 219
 - Time 219
 - Width 219
- RETRIG 157
- Ribbon
 - Controller 65
 - Hold 67
- Ring Modulator 98
 - Control 184
- ROM 18
- Rotary 57
- Sample and Hold 177
- Semitone 105
- Sequencer 71-78,100
- BPM 75
- Config 75
- Graph 74
- LPTYPE 75
- LPCNT 75
- MONLEG 75
- Progressor 77
- Step Size 78
- Sync 78
- Trigger 76
- Zoom 75
- Setup 21
- Shift Button 37
- Soft Knobs 33
- Soft Sync 115
- Software Upgrades 268
- Solo 42,245
- Specifications 274
- Split 47,48
- SRAM Card 45,94,101
- STEAL 50
- Store
 - Button 37
 - Parameters 43
- Sync/Mod Button 71
- Sync 115
 - LFO 176
- SYNSRC 70
- System Exclusive 253-254
 - Files 268
- TEMPO 70
- Tracking Generator 179-181
- Transpose 49,58,101
- Trigger 19
 - Envelope 154
 - LFO 175
 - Modulation 153,155
- Troubleshooting 265,270-271
- Tune 52,265-267
- Unison X 55,56
- Upgrading Software 268
- VCA 99
- VCF 98
- VCO 97
 - Modulation 107
- VCURVE 49
- Velocity
 - Curves 49
 - Sensitivity 49
- Voice 18
 - Mix 99,190
 - Monitor 51
 - Outputs 102,190
 - Stealing 50
- Volume 28,52
 - Pedal 25
- VOXMON 51
- VSENS 49
- Warranty 275
- WAVE 106,172
- Wheels 65-67